

# Analog Modules

Base Converter Module - IC697ALG230, Current Expander Module - IC697ALG440  
Voltage Expander Module - IC697ALG441

GFK-0385F  
August 1997

## Analog Input System, High Level, 16 Channels

### Features

- Complete Analog subsystem includes Base Converter and Expander modules
- Base Converter module has eight differential inputs individually configurable for voltage or current
- Accepts unipolar or bipolar Analog Inputs up to " 10 volts full scale
- Accepts 4 to 20 milliamp current loop signals
- Individual user scaling on each input channel on Base Converter module; scaling on a per module basis for Expander modules
- Fast update rate for Base Converter module
- Voltage and current Expander modules, each with 16 inputs, provides for additional inputs at a lower cost per point
- Complete subsystem can accept up to 120 inputs
- No jumpers or DIP switches to configure
- Easy configuration with MS-DOS® or Windows® programming software configuration function.

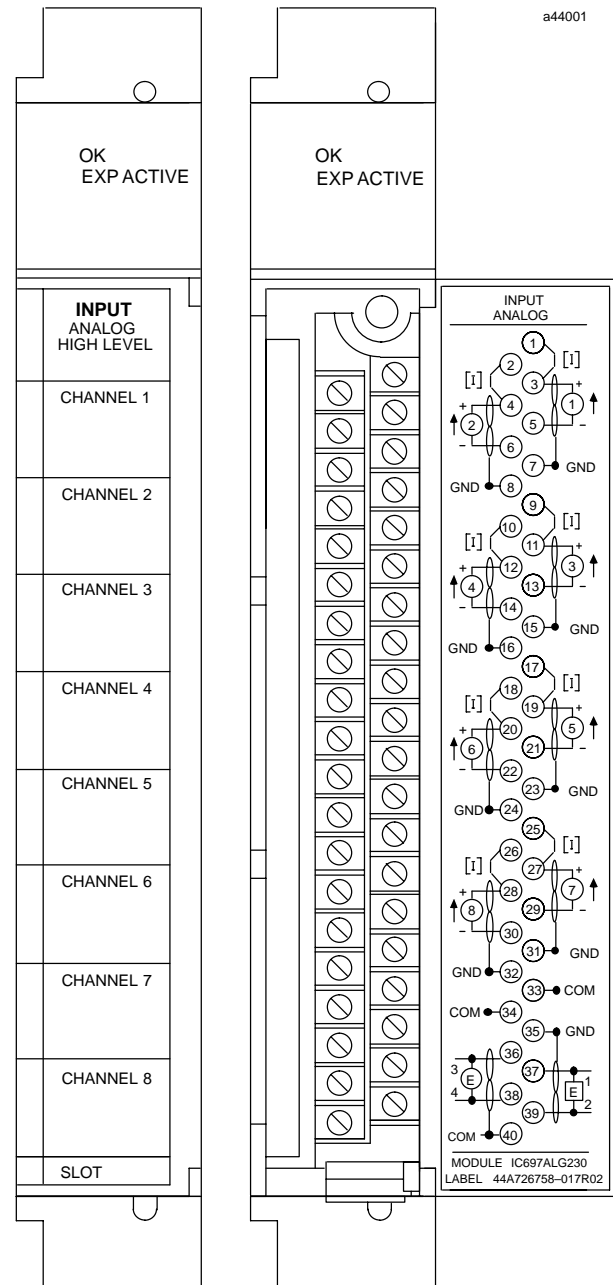

Figure 1. Base Converter Module

© IBM and PS/2 are registered trademarks of International Business Machines Corporation.

© MS-DOS, Windows, Windows 95, and Windows NT are registered trademarks of Microsoft Corporation.

GFK-0385F  
August 1997

Analog Input System, High Level, 16 Channels

Functions

The High Level Analog Input subsystem for the Programmable Logic Controller (PLC) accepts analog inputs of up to 10 volts full scale, or 4 to 20 milliamp current loop signals. These inputs are converted to digital form for use by the CPU or other controllers accessing analog inputs via the VME backplane.

Converted data is presented as 2's complement (sign + 15 bits). The basic converter is 14 bits resolution (1 part in 16384); an oversampling and averaging technique further enhances this resolution. Inputs are protected against transient and steady-state overvoltage conditions.

Analog inputs use %AI references in the programmable controller. A maximum of 8K words of %AI memory is currently available in the programmable controller. Each input channel uses one word (16 bits) of %AI memory.

Field wiring is made to a removable terminal board and the module is mechanically keyed to ensure correct replacement with a similar module type in the field. I/O references are user configurable without the use of jumpers or DIP switches on the module.

Configuration is done using the configuration function of the MS-DOS® or Windows® programming software running on Windows® 95 or Windows NT® over Ethernet TCP/IP or through the SNP port. The Programming Software configuration function is installed on the programming device. The programming device can be an IBM® XT, AT/PS/2® or compatible Personal Computer.

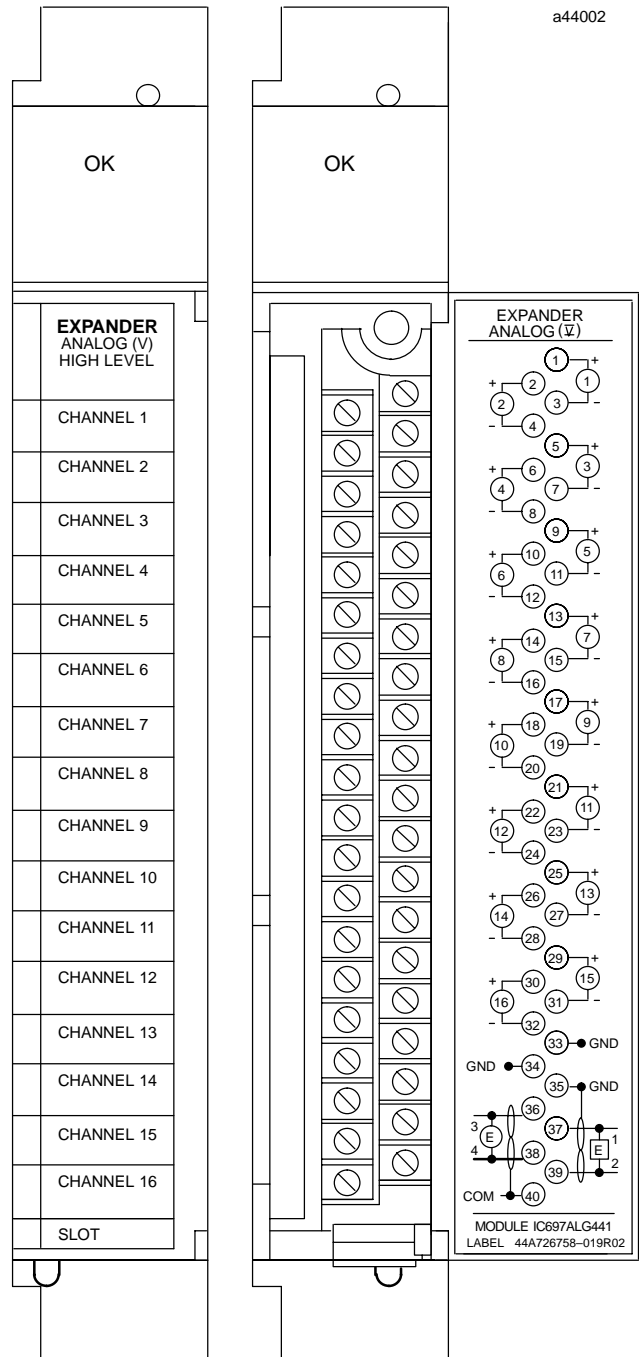

Figure 2. Expander Module

### High Level Analog Input System Modules

Three module types are included in the High Level Analog Input subsystem: a Base Converter module, a Current Expander module, and a Voltage Expander module. A typical subsystem will use a Base Converter module and (if required) one or more expander modules.

- **Base Converter module - catalog number IC697ALG230**

This module has eight differential inputs and an expansion port. Each input can be individually configured for either voltage or current. Each of the input channels also has individual user scaling.

On-board load resistors are included for normal input current ranges up to  $\approx 40$  mA. If other current ranges or different resolution is required, external resistors may be used.

Standard system configurations for  $\approx 10$  volts and 4 to 20 mA are available. These, and other lower input ranges, can be scaled to engineering units with the user scaling feature.

- **Expander Modules**

Up to seven Expander modules can be daisy-chained off the Base Converter module to increase the number of inputs of the total subsystem up to a maximum of 120.

The Base Converter module accepts any mix of the two Expander module types.

A common user scaling factor applies to all inputs on each Expander module, however each Expander module may be individually scaled as required.

- **Current Input Expander module - catalog number IC697ALG440**

The Current Expander module has 16 current inputs each accepting up to  $\approx 20$  mA.

- **Voltage Input Expander module - catalog number IC697ALG441**

The Voltage Expander module has 16 differential voltage inputs each accepting up to  $\approx 10$ V signals.

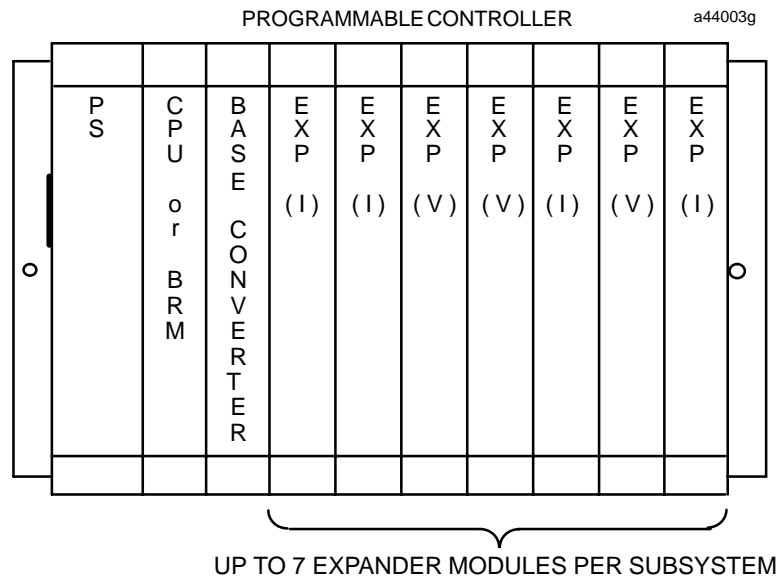

Figure 3. Example of High Level Analog Input System

GFK-0385F  
August 1997

Analog Input System, High Level, 16 Channels

System Operation

The following illustration is a block diagram of the High Level Analog Input system followed by an example of typical input connections.

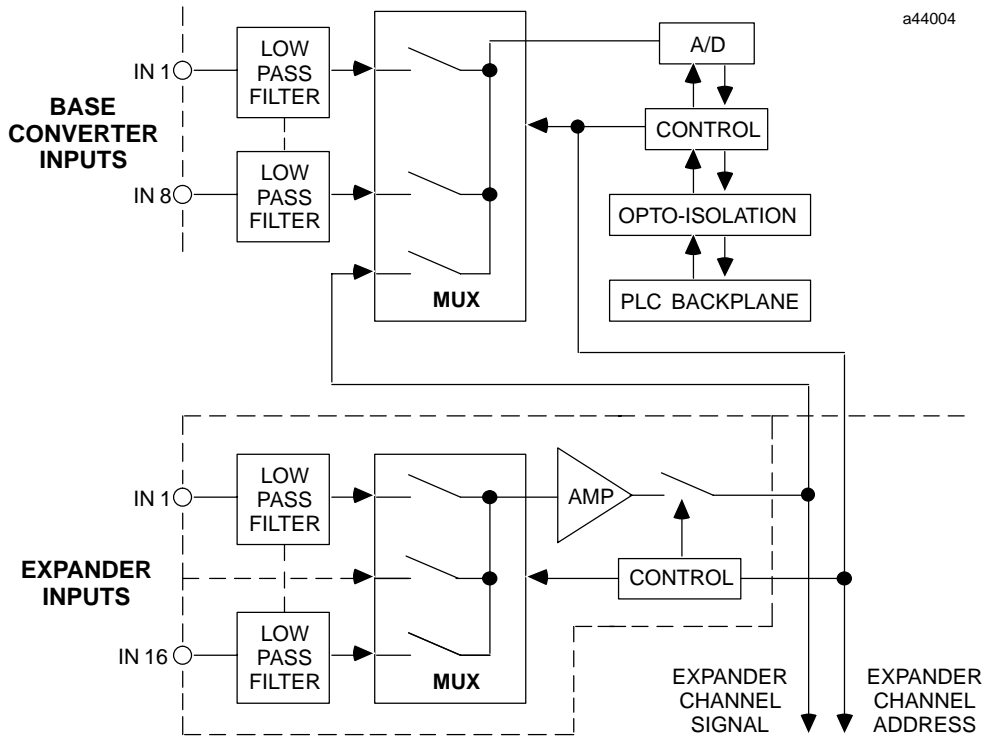

Figure 4. High Level Analog Input System Block Diagram

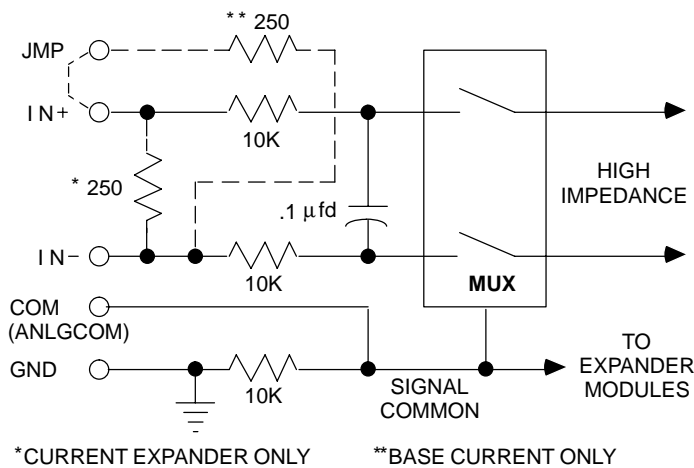

Figure 5. Example of Input Connections