

RTD Input Blocks

June 2002

GFK-0053C

Description

RTD Input blocks monitor temperature inputs from Resistive Temperature Detectors (RTDs). Two RTD blocks are available:

- **15 VAC/125 VDC RTD Block** (IC66*BBA101)
- **24/48 VDC RTD Block** (IC66*BBA021)

They are identical except for the power supply.

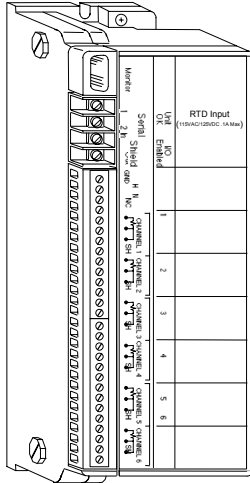

Features

An RTD Input block has six input circuits, in three groups of two circuits each. Group to group isolation is 300 volts. Each input can be used with platinum, nickel, or copper RTDs. Input data for each circuit is linearized according to the type of RTD selected. Input data is reported to the CPU in engineering units of tenths of degrees Celsius, tenths of degrees Fahrenheit, tenths of Ohms, or counts. Additional configurable features include:

- Alarm thresholds
- RTD resistance
- Alpha type
- Linearization
- Input filter time

RTD blocks are factory-calibrated; there is no need for subsequent recalibration.

In addition, the block's automatic diagnostics can pinpoint the cause of installation and run-time errors:

- Input Short detection
- Internal Fault detection
- Wiring Error detection
- Open Wire detection
- Overrange and Underrange input indication
- High and Low input alarms

Fault reporting can be enabled or disabled circuit-by-circuit.

Using this Datasheet

This datasheet summarizes information about block installation, configuration, and diagnostics.

Your primary reference should be the *Discrete and Analog Blocks User's Manual*. It includes detailed instructions for block installation and configuration.

For additional information about systems and communications, including bus specifications, refer to the *I/O System and Communications Manual*.

Specifications

Catalog Numbers

115 VAC/125 VDC RTD Block Terminal Assembly	IC66*BBA101 IC66*TBA101 IC66*EBA101
24/48 VDC RTD Block Terminal Assembly	C66*BBA021 IC66*TBA021 IC66*EBA021

Block Specifications

Size (height x width x depth)	8.83" (22.44cm) x 3.34" (8.48cm) x 3.91" (9.93cm)		
Weight	4 lbs. (1.8 kg)		
LEDs (I/O Block)	Unit OK, I/O Enabled		
Block to Block Isolation	1500V		
Group to Group Isolation	300V		
Heat Dissipation	7W maximum		
Block Power	115VAC	125VDC	24/48VDC
Power supply voltage (@ 7W)	93-132 VAC 47-63 Hz	105-145 VDC 10% max. ripple	18-56 VDC 10% max. ripple
Power supply dropout time	1 cycle	10ms	10ms

Input Specifications

Input resolution	0.1° C
Absolute accuracy (at 25°C)* Platinum or Nickel 10W Copper:	+/-0.5 °C typical, +/-1.0°C maximum +/-5°C typical, +/-10°C maximum
Input update frequency	Once every 400ms, 800ms, or 1600ms
Input filter ranges (per block)	400ms, 800ms, 1600ms
RTD linearization	Platinum (DIN 43760), Nickel (DIN 43760), Copper, Linear
Resistance measurement range	0 to 5000 Ohms
Diagnostics	Input shorted, Internal fault, Wiring error, Open wire, Overrange, Underrange, High Alarm, Low Alarm

Refer to GFK-0867 for product standards and general specifications.

*In the presence of severe RF interference (IEC 801-3, 10 V/m), accuracy may be degraded to +/- (0.5% of full scale reading, plus 0.5% of reading).

Compatibility

Hand-held Monitor IC66*HMM501D, version 3.5 (or later) is required.

For an IC697 series PLC, the CPU may be rel. 1 (IC697CPU731 or 771) or later. The bus controller may be rel. 1 (IC697BEM731) or later.

For an IC600 series PLC, the CPU must be rev. 105 or later. For a IC600 series Plus PLC, rev. 110 or later is required. The programming software must be Logicmaster™ 6 rel. 4.02 or later.

For an IC550 series PLC, the CPU must be rev. 3.0 or later. The programming software must be rel. 2.01 or later.

RTD Input Blocks

June 2002

GFK-0053C

Installation Instructions

Carefully inspect all shipping containers for damage. If any equipment is damaged, notify the delivery service immediately. Save the damaged shipping container for inspection by the delivery service. After unpacking the equipment, record all serial numbers. Save the shipping containers and packing material in case it is necessary to transport or ship any part of the system.

Block Mounting

Genius I/O blocks are considered "open equipment" and therefore must be installed within a protective enclosure. They should be located in an area that is clean and free of airborne contaminants. There should be adequate cooling airflow.

The block can be mounted right side up, or upside down. Leave at least 2 inches of space between blocks. Mount the block by drilling two screw or bolt holes for 8-32 hardware. Position the block so that the notches in the upper and lower flanges line up with the mounting holes. Mount the block using 8-32 screws. Use star washers to provide ground integrity.

Grounding

The block's mounting screws must not be used as the only means of grounding the block. Connect the green ground screw on the block to a reliable ground system using a short wire lead, minimum size AWG #12 (avg 3.3mm² in cross-section).

Warning

If mounting screws do not make good ground connection and the ground screw is not connected to a reliable ground, the block is not grounded. Electrical shock hazard exists. Death or personal injury may result.

Block Wiring

Do not overtorque the terminal screws. Recommended torque for all terminals is 6 in/lb (.678 N/M).

Serial Bus Wiring

Terminals 1 to 4 are for the serial bus. These terminals accept one AWG #12 wire (avg 3.3mm² cross-section) or two AWG #14 wires (each avg 2.1mm² in cross-section). The minimum recommended wire size is AWG #22 (avg .36mm² in cross-section).

Terminals 1 - 4 can also accommodate spade or ring terminals up to 0.27 inch (6.85mm) wide with a minimum opening for a #6 screw, and up to 0.20 inch (5.1mm) depth from the screw center to the back barrier. Be sure unshielded wire ends are not longer than 2 inches (5 cm).

Using one of the cable types recommended in the *System and Communications User's Manual*, connect the serial bus to terminals 1-4.

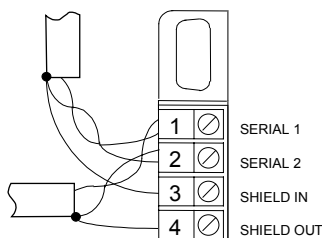

If the block is at either end of the bus, connect a terminating resistor of the appropriate type (see the System and Communications User's Manual for details) across its Serial 1 and Serial 2 terminals.

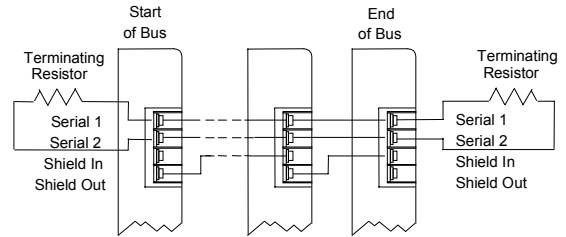

Field Wiring

Terminals 5 to 32 are for field devices. They take a single wire up to AWG #14 (avg 2.1mm² in cross-section). Minimum recommended size is AWG #20 (avg .54mm² in cross-section).

Wiring for Block Power

For block power, connect the power source to terminals 6 and 7. For an AC block, connect the AC source to the HOT terminal and neutral to the NEUT terminal. For a DC block, connect the DC source to the DC+ terminal and the return to the DC- terminal.

The ground (GND) terminal (5) is for block safety. It is connected to the block chassis.

Wiring for Input Devices

There are 4 terminals available for each input device: a SIG, RTN, REF, and SHLD input. Connect RTDs between the SIG and RTN terminals.

The REF input is used for lead wire compensation of a 3-wire RTD. For a 3-wire RTD, connect the third wire to the REF terminal. For 2-wire RTDs, short the REF terminal to the RTN terminal.

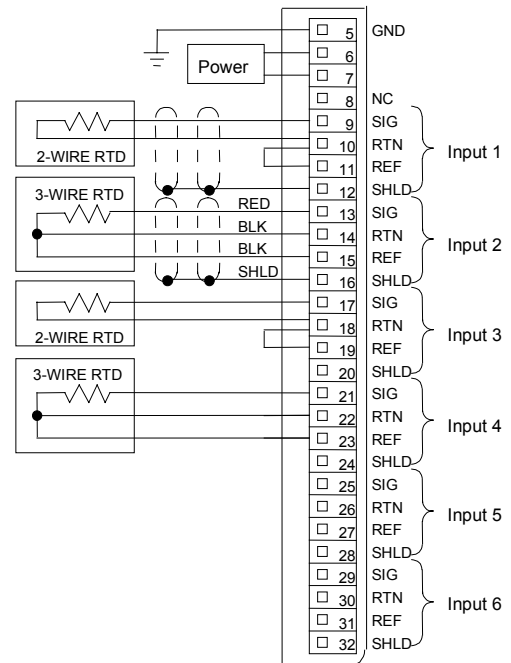

Each circuit also has a SHLD terminal for shield termination, if desired. This terminal is internally connected to the block chassis and to the input power safety ground terminal.

RTD Input Blocks

June 2002

GFK-0053C

Noise Suppression

If noise spikes exceeding 4000 volts will be present in the system, additional noise suppression is needed to protect the block.

This can be provided by physically separating and shielding the RTD input leads from any noise source.

Alternatively, metal oxide varistors can be installed between RTN and GND.

See the *I/O System and Communications Manual and Discrete and Analog Blocks User's Manual* for additional information.

Removing an Electronics Assembly

The block's Electronics Assembly can be replaced with a compatible model without removing field wiring or reconfiguring the block.

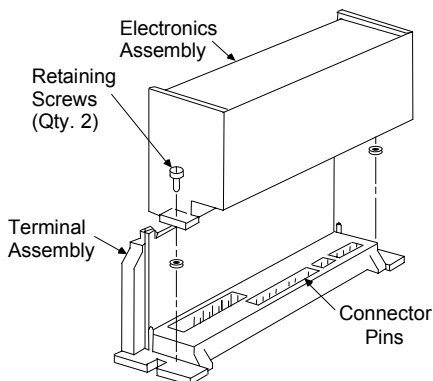

1. Unscrew the retaining screws at the top and bottom of the block.
2. Using a Block Puller (IC660BLM507), engage the tabs in the first vent slots. Move the tool to the center of the block and squeeze the handle.
3. Pull the Electronics Assembly upward.

Warning

If power is applied to the field terminals, power is also exposed on the connector pins at the base of the Terminal Assembly, and electrical shock hazard exists. Do not touch the connector pins! Death or injury may result.

Inserting an Electronics Assembly

1. Align the Electronics Assembly in the guides and push down firmly.

Caution

Do not exert excessive force; it may damage the block.

2. If unusual resistance is met, remove the Electronics Assembly. If power is applied to the block, DO NOT TOUCH THE CONNECTOR PINS! Inspect the Terminal Assembly, connector receptacle, and connector edge board (on the Electronics Assembly). Be sure the keying matches. Remove any obstacles and reinsert the Electronics Assembly. Pay close attention to the alignment of the guide pins.
3. Secure the Electronics Assembly with the screws on the top and bottom of the Terminal Assembly.

Note: If the Electronics Assembly has been removed from a block for some length of time, contaminants may have built up on the exposed connector pins. After the block is reassembled, these contaminants could affect the accuracy of measurements. When reassembling the block, push the Electronics Assembly in and out a few times to assure a fresh mating surface.

Block Operation

For each pair of inputs, a multiplexer switches the A/D converter between the RTD inputs and internal reference resistors that are used for self-calibration. The following diagram shows one pair of inputs.

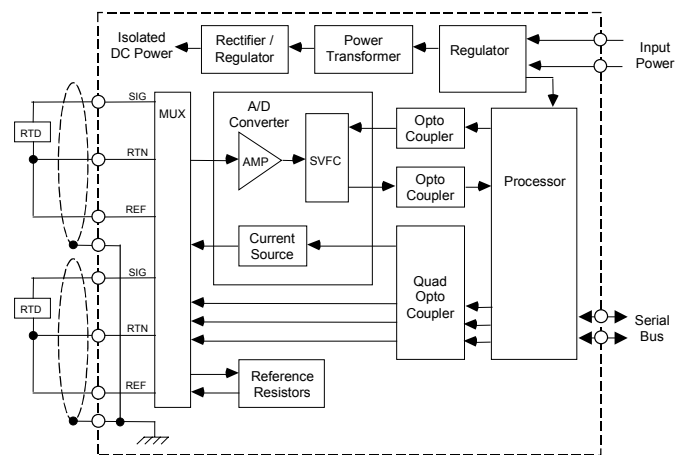

Opto-couplers isolate the control and clock signals; a small transformer isolates the circuit power. A synchronous voltage-to-frequency converter changes the measured signals to the proportional frequency sent via an opto-coupler to the processor. The processor's frequency counter converts this synchronous frequency to a 16-bit binary number.

The processor corrects each input measurement for lead resistance and for internal offset and gain drifts as it converts the input to an ohmic value. This value is either reported as is, or linearized according to the RTD type selected and converted to a value in degrees. The per channel update rate (input filter time) is preset. It may be 400, 800, or 1600 milliseconds. These selections provide 14, 15, or 16 bit resolution of the measurement.

LEDs

The block's Unit OK and I/O Enabled LEDs show its operating status:

Unit OK	I/O Enabled	Meaning
ON	ON	Block functioning, CPU communicating
ON	OFF	Block functioning No CPU communications for 3 bus scans
ON	Blinking	Block functioning, Circuit forced
Blinking	ON	Circuit fault, CPU communicating
Blinking	OFF	Circuit fault No CPU communications for 3 bus scans
Alternate Blinking		Circuit fault, Circuit forced
Synchronous Blinking		No CPU communications - block number conflict
OFF	OFF	No block power, or block faulty