

Analog Input, 16-Bit RTD Module

August 2004

GFK-1523C

Product Description

The Analog Input RTD Module is an intelligent module that accepts input signals from up to 4 RTD input devices and provides input data with 16 bits of resolution.

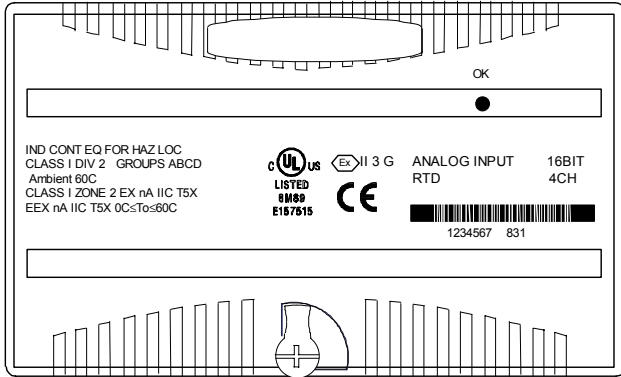

No external power supply is required for this module. The excitation current for the RTDs is provided by the module, which automatically matches the excitation current to each configured RTD type.

The module accepts inputs from 4 independent 3-wire and/or 4-wire platinum, nickel, nickel/iron, or copper RTDs.

Module features include:

- Selectable resistance measurements in tenths of ohms, tenths of degrees Fahrenheit, or tenths of degrees Celsius
- Individual channel configuration
- Selectable resistance ranges: 0 – 500 ohms and 0 – 3000 ohms
- Selectable RTD input as resistance or temperature (Celsius or Fahrenheit)
- Reports high/low, underrange/overrange, open wire and input short alarms.
- Two data acquisition rates based on 50 Hz and 60 Hz line frequencies
- Configurable channel activation

The module automatically performs A/D calibration at powerup. Automatic calibration is then repeated periodically to compensate for changes in the ambient temperature.

Host Interface

The RTD Module provides 4 words of analog input data.

Diagnostics

Over/under range, open wire, input short, non-volatile memory storage fault, wiring fault, and high/low alarm.

LED Indicators

The green FLD PWR LED indicates the presence of both backplane power and field power for the analog field-side circuits.

The OK LED indicates module status:

- On green indicates normal operation
- Flashing green indicates boot mode or update
- Flashing amber indicates self-diagnostic error
- Off indicates no 3.3V backplane power

Module Characteristics

Channels	Four 3-wire and/or 4-wire RTDs
Module ID	FFFF9803
Isolation:	
User input to logic (optical) and to frame ground	250VAC continuous; 1500VAC for 1 minute
Group to group	Not applicable
Channel to channel	50VDC
LED indicators	OK LED: Green indicates backplane power is present. Amber indicates a module fault.
Backplane current consumption	5V output: 125mA maximum. 3.3V output: 125mA
External power supply	None
Thermal derating	None
Configuration parameters	See configuration table
Diagnostics	Open RTD, input short, underrange, overrange, non-volatile memory storage fault, wiring fault and high/low alarm
Update rate	60 Hz: approximately 210 ms per channel 50 Hz: approximately 230 ms per channel
Normal mode rejection	60dB, at 50/60 Hz, 100% span
Common mode rejection	120 dB at 50/60Hz, 100 ohm imbalance
Common mode voltage	3V maximum
Normal mode voltage	5V maximum
Digital Resolution	15 bits plus sign
Operating temperature range	0 to 60 Degrees C ambient

Input Characteristics:

RTD types	25, 100, and 1000 ohm platinum 10, 50, and 100 ohm copper 100 and 120 ohm nickel 604 ohms nickel/iron
Resistance ranges	0 to 500 ohms 0 to 3000 ohms
Accuracy, at 25° C	+/-0.15% on resistance measurement +/-0.15% on RTD (temperature) measurement
Temperature sensitivity (0° to 60°C)	+/-0.004% of reading, +/-1.5µV per °C referred to input
Maximum lead resistance	5 ohms per lead

Preinstallation Check

Carefully inspect all shipping containers for damage. If any equipment is damaged, notify the delivery service immediately. Save the damaged shipping container for inspection by the delivery service. After unpacking the equipment, record all serial numbers. Save the shipping containers and packing material in case it is necessary to transport or ship any part of the system.

Analog Input, 16-Bit RTD Module

August 2004

GFK-1523C

Field Wiring Terminals

Terminal assignments for the module are shown below.

Number	Connection	Number	Connection
A1	Source 1	B1	No connection
A2	In (+) 1	B2	Shield Termination Point
A3	In (-) 1	B3	No connection
A4	Return 1	B4	Shield Termination Point
A5	Source 2	B5	No connection
A6	In (+) 2	B6	Shield Termination Point
A7	In (-) 2	B7	No connection
A8	Return 2	B8	Shield Termination Point
A9	Source 3	B9	No connection
A10	In (+) 3	B10	Shield Termination Point
A11	In (-) 3	B11	No connection
A12	Return 3	B12	Shield Termination Point
A13	Source 4	B13	No connection
A14	In (+) 4	B14	Shield Termination Point
A15	In (-) 4	B15	No connection
A16	Return 4	B16	No connection
A17	No connection	B17	No connection
A18	No connection	B18	No connection

Wiring Connections for Carriers with Two Rows of Terminals

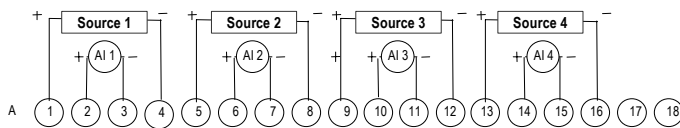

Wiring Connections for Carriers with Three Rows of Terminals

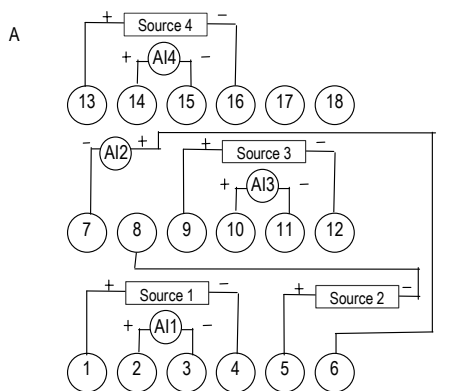

Wiring Examples

The following illustration shows connections for 3-wire and 4-wire RTDs. No external power supply is required for this module. The excitation current for the RTDs is provided by the module, which automatically matches the excitation current to each configured RTD type.

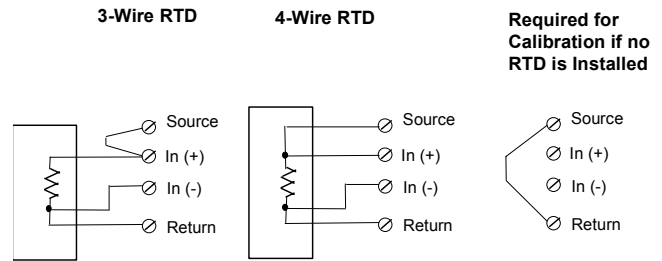

Cable Shield Connections

If possible, the cable should be grounded at the source device. If that is not possible, the cable shield must be grounded at the source device. If that is not possible, the cable shield must be grounded at the I/O module. This can be done using an Auxiliary I/O Terminal (IC200TBM001, 002, or 005).

If the module is installed on a Terminal-style I/O Carrier (IC200CHS001, 002, or 005), shield connections can be made on an Auxiliary I/O Terminal that is attached to the I/O carrier.

If the module is installed on a Compact Terminal-style I/O Carrier (IC200CHS022, 025), shield connections can be made on an Auxiliary I/O Terminal that is mounted near the I/O carrier. Be sure to ground the Auxiliary I/O Terminal Strip if you plan to use it for this purpose.

If the module is installed on a Connector-style I/O Carrier (IC200CHS003), the cable shield can be connected directly to an Interposing Terminal (IC200CHS011, 012, 015). Be sure to ground the Interposing Terminal. It is recommended to use a shielded interposing cable as well between the Interposing Terminal and the Connector Base. A custom shielded cable can be made using the Connector kit (IC200ACC302). In addition, a custom shield braid can be wrapped around standard Interposing Cables (IC200CBL105, 110, 120, 230). If this approach is used be sure to ground the braid.

Analog Input, 16-Bit RTD Module

August 2004

GFK-1523C

Product Version Information

This version can be configured to use a 50Hz frequency filter.
LED flash codes provide enhanced error detection.

Revision Letters:	CB
Firmware version:	1.10
Firmware upgrade kit:	44A752834-G01

Compatibility

This module is compatible with:

- PLC CPU firmware version 1.20 or later.
- Ethernet NIU EBI001 all versions.
- Genius NIU GBI001 Firmware version 1.10 or later*
- Profibus NIU PBI001 Firmware version 1.10 or later*
- DeviceNet NIU DBI001 Firmware version 2.10 or later

* For GBI001 and PBI001, NIU version 2.0 or above is required to perform software configuration.

Operating Note

After rapid power cycles or certain brownout conditions, the module may blink a 6-3 error code indicating a hardware failure. Cycle power to the module to stop the blinking.

Fixed for this Release

This release of the module operates properly and does not flash an error code if its hardware configuration is set for 50Hz line frequency

Configurable Features

The default parameters of this module can be used in many applications. The module can be software-configured when it is installed in a PLC system, or an I/O Station controlled by a Network Interface Unit that supports software configuration, as listed on the previous page.

The module is configured at startup. After configuration, the module begins providing signals from the voltage or current output devices connected to it to the CPU or NIU.

Parameter	Default	Choices
Analog Input Data Length	4	0-4
Analog Input Data Reference		user selectable
Line Frequency	60 Hz	50 Hz, 60 Hz
Channel Active	Active	Inactive (off), Active (on)
Units	Deg C	tenths of ohms, tenths of degrees C, or tenths of degrees F
RTD Type	100 PT 385	10 PT, 25 PT, 25.5 PT 392, 100 PT 385, 100 PT 3902, 100 PT 392, 100 PT 3923, 100 PT 3916, 1K PT 375, 10 CU, 10 CU 427, 50 CU 427, 100 CU 427, 100 NI, 100 NI 618, 120 NI 672 604 NI/FE 518, 1K NI/FE 527, 500 Ohm, 3000 Ohm
Wire Type	3 Wire	3 Wire, 4 Wire
Alarm Low	-200	-32,768 to +32,767
Alarm High	800	-32,768 to +32,767
Nominal Resistance	0	0 to 3276.7
Channel Default Input	0	± 3276.7

Description of Configurable Features

Channel Active: Each channel can be configured as either active or inactive. If a channel is inactive, it is not scanned and a value of 0 is returned by the module.

Input Units: Inputs can be measured as tenths of Ohms, tenths of degrees C, or tenths of degrees F. The default is tenths of degrees C. The measurable ranges for each type of input units are shown below.

Units Selected	Integer Ranges	Engineering Units Ranges
Tenths of Degrees	-32767 to +32767	-3276.7° to +3276.7°
Tenths of Ohms	0 to 65535	0 Ohms to 6553.5 Ohms

Low Alarm Limit and High Alarm Limit: Each input channel can have a low alarm limit and a high alarm limit. If an input reaches one of its limits, the module reports the actual value and sends the appropriate diagnostic input bit. Alarms do not stop the process or change the value of the input.

Alarm limits can be set anywhere over the dynamic range of the signal. The range for each is -32,768 to +32,767. The high alarm limit must be greater than the low alarm limit. If alarm reporting is not wanted, alarm limits can be set beyond the dynamic range of the signal so they will never be activated.

Analog Input, 16-Bit RTD Module

August 2004

GFK-1523C

Input Selection to Include RTD Type: Each input channel can have a different RTD type. The module supports the RTD types listed below. If the actual RTD resistance does not match a defined type, an adjustment factor can be configured in tenths of ohms.

Selection	Comments
25.5 PT 392	25.5 Ohm Platinum, $\alpha = .00392$ at 0°C Lab Std
100 PT 385	100 Ohm Platinum, DIN43760, $\alpha = .00385$
100 PT 3902	100 Ohm Platinum, $\alpha = .003902$
100 PT 392	100 Ohm Platinum, $\alpha = .00392$ IPTS-6 8
100 PT 3923	98.13 Ohm Platinum, $\alpha = .003923$
100 PT 3916	100 Ohm Platinum, $\alpha = .003916$
1K PT 375	1 KOhm Platinum, $\alpha = .00375$
10 CU	10 Ohm Copper, at 25°C, IPTS-68
9.035 CU 427	9.035 Ohm Copper, at 25°C, $\alpha = .00427$
50 CU 427	50 Ohm Copper, $\alpha = .00427$
100 CU 427	100 Ohm Copper, $\alpha = .00427$
100 NI 618	100 Ohm Nickel At 0°C, DIN43760, $\alpha = .00618$
120 NI 672	120 Ohm Nickel, at 0°C, $\alpha = .00672$
604 NI/FE 518	604 Ohm Nickel/Iron, at 0°C, $\alpha = .00518$
500 OHM	Select UNITS of 1/10 Ohms
3000 OHM	Select UNITS of 1/10 Ohms

RTD Limits: The table below lists the ohms and temperature limits for different RTD types.

<i>RTD Type</i>	<i>Low Ohms Limit</i>	<i>High Ohms Limit</i>	<i>Low Temp. °C</i>	<i>High Temp. °C</i>
10 Ohm Copper @ 25°C	6.13600	14.8200	-75.00	150.00
10 Ohm Platinum @ 25°C	7.02000	37.2599	-70.00	1000.00
1 KOhm Platinum, $\alpha = .00375$	199.4880	2754.620	-200.00	500.00
100 Ohm Platinum $\alpha = .00385$	27.01	389.936	-180.0	850.0
100 Ohm Platinum, $\alpha = .003902$	93.5400	135.000	-17.7777	99.9999
100 Ohm Platinum IPTS68 (PA)	26.5	327.744	-200.0	630.0
100 Ohm Platinum SAMA-RC21-4 (PC)	26.5	311.874	-200.0	600.0
100 Ohm Platinum JISC-1604-81	26.5	323.780	-200.0	620.0
25.5 Ohm Platinum Lab Std (PJ)	4.50	83.575	-200.0	630.0
9.035 Ohm Copper (CA)	6.05	16.400	-100.0	260.0
50 Ohm Copper (CB/2)	28.379	105.787	-100.0	260.0
100 Ohm Copper (CB)	56.757	211.574	-100.0	260.0
100 Ohm Nickel (NB)	69.520	223.221	-60.0	180.0
120 Ohm Nickel (NA)	66.600	380.310	-80.0	260.0
604 Ohm Nickel/Iron (FA)	372.789	1318.722	-100.0	204.0