

VersaMax AC Input Modules

May 2009

GFK-2464B

Product Description

These discrete input modules have positive logic or sourcing-type inputs; they receive current from AC input devices and return the current on the common. Input devices are connected between the input terminals and common terminals.

Discrete Input Modules IC200MDL140, IC200MDL141, BXIOIA8120 and BXIOIA8240 provide one group of 8 discrete inputs.

Discrete Input Modules IC200MDL240, IC200MDL241 (shown below), and BXIOIA16120 provide two groups of 8 discrete inputs.

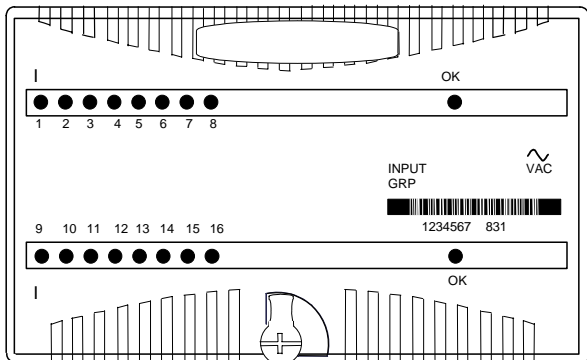

Power for module operation comes from the backplane.

Intelligent processing for the module is performed by the CPU or NIU.

LED Indicators

Individual green LEDs indicate the on/off state of each input point.

The green OK LED is on when backplane power is present to the module.

Product Revision History

Rev	Date	Description
IC200MDL140F / BXIOIA8120F IC200MDL141F / BXIOIA8240F IC200MDL240G / BXIOIA16120G IC200MDL241G	May 2009	Change of manufacturing location.
IC200MDL140E / BXIOIA8120E IC200MDL141E / BXIOIA8240E IC200MDL240F / BXIOIA16120F IC200MDL241F	Oct. 2008	Updated Power Supply OK signal circuitry.
IC200MDL140D / BXIOIA8120D IC200MDL141D / BXIOIA8240D IC200MDL240E / BXIOIA16120E IC200MDL241E	Apr. 2005	Plastic change on locking mechanism
IC200MDL140C IC200MDL141C IC200MDL240D IC200MDL241D	Apr. 2004	Changed to V0 plastic for module housing.
BXIOIA8120C BXIOIA8240C BXIOIA16120D	Jan. 2004	Changed to V0 plastic for module housing. ATEX approval for Group 2 Category 3 applications.
IC200MDL140B IC200MDL141B IC200MDL240C IC200MDL241C	Jan. 2004	ATEX approval for Group 2 Category 3 applications.
IC200MDL140A / BXIOIA8120A IC200MDL141A / BXIOIA8240A	Mar. 1999	Initial product release
IC200MDL240A / BXIOIA16120A IC200MDL241A	Sep. 1998	Initial product release

Module Characteristics

Points	IC200MDL140, IC200MDL141, BXIOIA120, and BXIOIA240: 8 inputs (1 group of 8) IC200MDL240, IC200MDL241, BXIOIA16120: 16 inputs (2 groups of 8)
Module ID	IC200MDL14*, BXIOIA8*** : FFFF8804 IC200MDL24*, BXIOIA16120: 88048804
Isolation:	User input to logic (optical) and frame ground 250VAC continuous; 1500VAC for 1 minute Group to group: 8 pts: not applicable 16 pts: 250VAC continuous; 1500VAC for 1 minute Point to point : None
LED indicators	One LED per point shows individual point ON/OFF status OK LED indicates backplane power is present
Backplane current consumption (5V output)	IC200MDL14*, BXIOIA8*** : 55mA maximum IC200MDL24*, BXIOIA16120: 110mA maximum
External power supply	None
Thermal derating	IC200MDL14*, BXIOIA8***: None IC200MDL24*, BXIOIA16120: See next page

Input Characteristics

Input voltage	IC200MDL*40, BXIOIA8120, BXIOIA16120: 0 to 132VAC (47 to 63Hz), 120VAC nominal IC200MDL*41, BXIOIA8240: 0 to 264VAC (47 to 63Hz), 240VAC nominal
On state voltage	IC200MDL*40, BXIOIA8120, BXIOIA16120: 70 to 132VAC IC200MDL*41, BXIOIA8240: 155 to 264VAC
Off state voltage	IC200MDL*40, BXIOIA8120, BXIOIA16120: 0 to 20VAC IC200MDL*41, BXIOIA8240: 0 to 40VAC
On state current	IC200MDL*40, BXIOIA8120, BXIOIA16120: 5mA minimum IC200MDL*41, BXIOIA8240: 7mA minimum
Off state current	IC200MDL*40, BXIOIA8120, BXIOIA16120: 2.5mA maximum IC200MDL*41, BXIOIA8240: 1.5mA maximum
On response time Off response time	1 cycle maximum 2 cycles maximum
Input impedance at 60Hz, typical	IC200MDL*40, BXIOIA8120, BXIOIA16120: 8.6kOhms (reactive) IC200MDL*41, BXIOIA8240: 38.5kOhms (reactive) at 60Hz
Input impedance at 50Hz, typical	IC200MDL*40, BXIOIA8120, BXIOIA16120: 10.32kOhms (reactive) IC200MDL*41, BXIOIA8240: 46.3kOhms (reactive) at 50Hz

Installation in Hazardous Locations

- EQUIPMENT LABELED WITH REFERENCE TO CLASS I, GROUPS A, B, C & D, DIV. 2 HAZARDOUS LOCATIONS IS SUITABLE FOR USE IN CLASS I, DIVISION 2, GROUPS A, B, C, D OR NON-HAZARDOUS LOCATIONS ONLY
- WARNING - EXPLOSION HAZARD - SUBSTITUTION OF COMPONENTS MAY IMPAIR SUITABILITY FOR CLASS I, DIVISION 2;
- WARNING - EXPLOSION HAZARD - WHEN IN HAZARDOUS LOCATIONS, TURN OFF POWER BEFORE REPLACING OR WIRING MODULES; AND
- WARNING - EXPLOSION HAZARD - DO NOT DISCONNECT EQUIPMENT UNLESS POWER HAS BEEN SWITCHED OFF OR THE AREA IS KNOWN TO BE NONHAZARDOUS.

VersaMax AC Input Modules

May 2009

GFK-2464B

Preinstallation Check

Carefully inspect all shipping containers for damage. If any equipment is damaged, notify the delivery service immediately. Save the damaged shipping container for inspection by the delivery service. After unpacking the equipment, record all serial numbers. Save the shipping containers and packing material in case it is necessary to transport or ship any part of the system.

Field Wiring Terminals

Terminal	Connection	Terminal	Connection
A1	Input 1	B1	Input 9 *
A2	Input 2	B2	Input 10 *
A3	Input 3	B3	Input 11 *
A4	Input 4	B4	Input 12 *
A5	Input 5	B5	Input 13 *
A6	Input 6	B6	Input 14 *
A7	Input 7	B7	Input 15 *
A8	Input 8	B8	Input 16 *
A9	No connection	B9	No connection
A10	No connection	B10	No connection
A11	No connection	B11	No connection
A12	No connection	B12	No connection
A13	No connection	B13	No connection
A14	No connection	B14	No connection
A15	No connection	B15	No connection
A16	No connection	B16	No connection
A17	Inputs 1-8 Common (Return)	B17	Inputs 9-16 * Common (Return)
A18	No connection	B18	No connection

* Inputs available on 16-point modules only.

Wiring Connections for Carriers with Two Rows of Terminals

Row B connections shown below are for 16-point modules only.

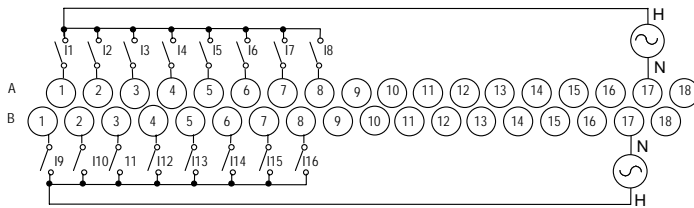

Wiring Connections for Carriers with Three Rows of Terminals

Side B connections shown below are for 16-point modules only.

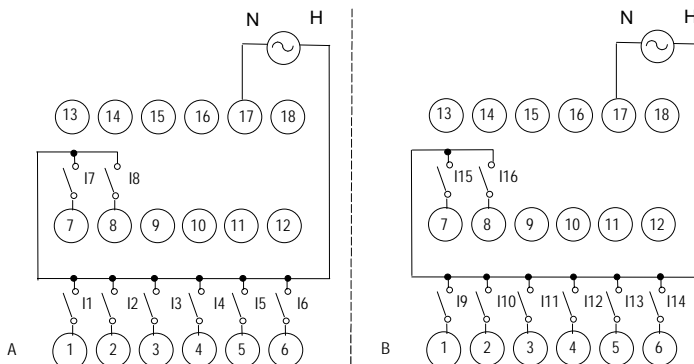

Operating Note

If hot insertion of a module is done improperly, the operation of other modules on the same backplane may be disrupted. See *Installing a Module on a Carrier* in the *VersaMax Modules Manual*, GFK-1504.

Thermal Derating

No derating is required for the 8-point modules in any orientation, or for the 16-point modules if they are mounted vertically (A, B) on the DIN rail.

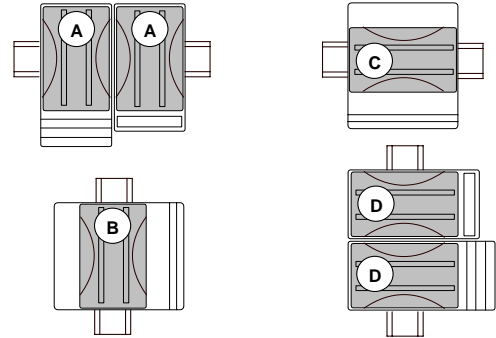

For IC200MDL240 and BXIOIA16120 modules that are mounted horizontally (C, D) on the DIN rail, no derating is required at 120VAC. Deratings at 132VAC are shown below.

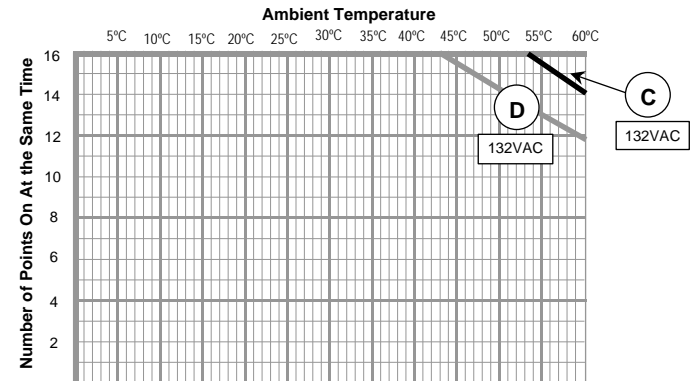

For IC200MDL241 modules that are mounted horizontally (C, D) on the DIN rail, no derating is required for voltages up to 240VAC. Deratings at 264VAC are shown below.

