

Analog Modules

Base Converter Module - IC697ALG230
 Current Expander Module - IC697ALG440/IC697ALG444
 Voltage Expander Module - IC697ALG441/IC697ALG445

GFK-0385G
 March 11, 2008

Features

- Complete Analog subsystem includes Base Converter and Expander modules
- Base Converter module has eight differential inputs individually configurable for voltage or current
- Accepts unipolar or bipolar Analog Inputs up to " 10 volts full scale
- Accepts 4 to 20 milliamp current loop signals
- Individual user scaling on each input channel on Base Converter module; scaling on a per module basis for Expander modules
- Fast update rate for Base Converter module
- Voltage and current Expander modules, each with 16 inputs, provides for additional inputs at a lower cost per point
- Complete subsystem can accept up to 120 inputs
- No jumpers or DIP switches to configure
- Easy configuration with programming software.

Release Information

The ALG444 and ALG445 incorporate the same circuitry as the ALG440 and ALG441 respectively, but also provide gold-plated contacts on the headers and terminal blocks.

Hardware Configuration

If the ALG444 and ALG445 are not available as selections in the hardware configuration of the programming software, they can be configured by selecting the corresponding module with standard contacts.

Functional Compatibility

The ALG444 and ALG445 are compatible with all Series 90-70 and RX7i backplanes and expansion racks.

For ALG230, ALG440 and ALG441 compatibility, refer to the appropriate system *Installation Manual*.

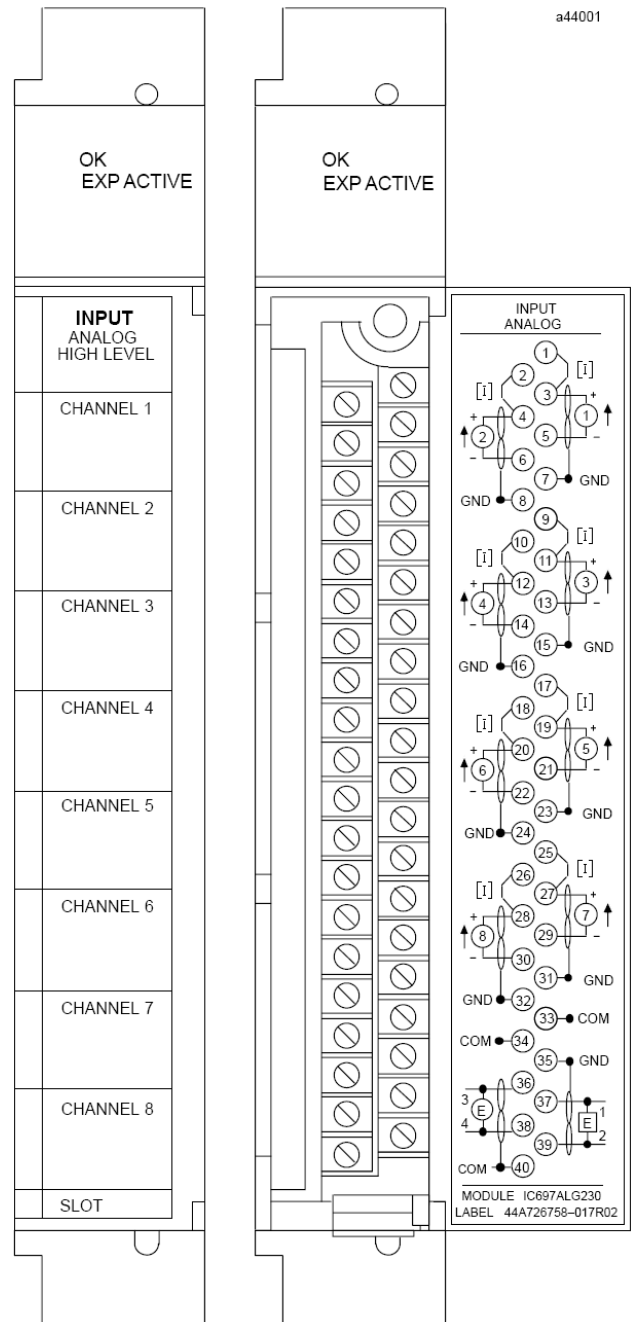

Base Converter Module

GFK-0385G

Functions

The High Level Analog Input subsystem for the Programmable Logic Controller (PLC) accepts analog inputs of up to 10 volts full scale, or 4 to 20 milliamp current loop signals. These inputs are converted to digital form for use by the CPU or other controllers accessing analog inputs via the VME backplane.

Converted data is presented as 2's complement (sign + 15 bits). The basic converter is 14 bits resolution (1 part in 16384); an oversampling and averaging technique further enhances this resolution. Inputs are protected against transient and steady-state overvoltage conditions. Analog inputs use %AI references in the programmable controller. A maximum of 8K words of %AI memory is currently available in the programmable controller. Each input channel uses one word (16 bits) of %AI memory.

Field wiring is made to a removable terminal board and the module is mechanically keyed to ensure correct replacement with a similar module type in the field. I/O references are user configurable without the use of jumpers or DIP switches on the module.

The system is configured using the programming software. For details, refer to the *Programming Software User's Manual*.

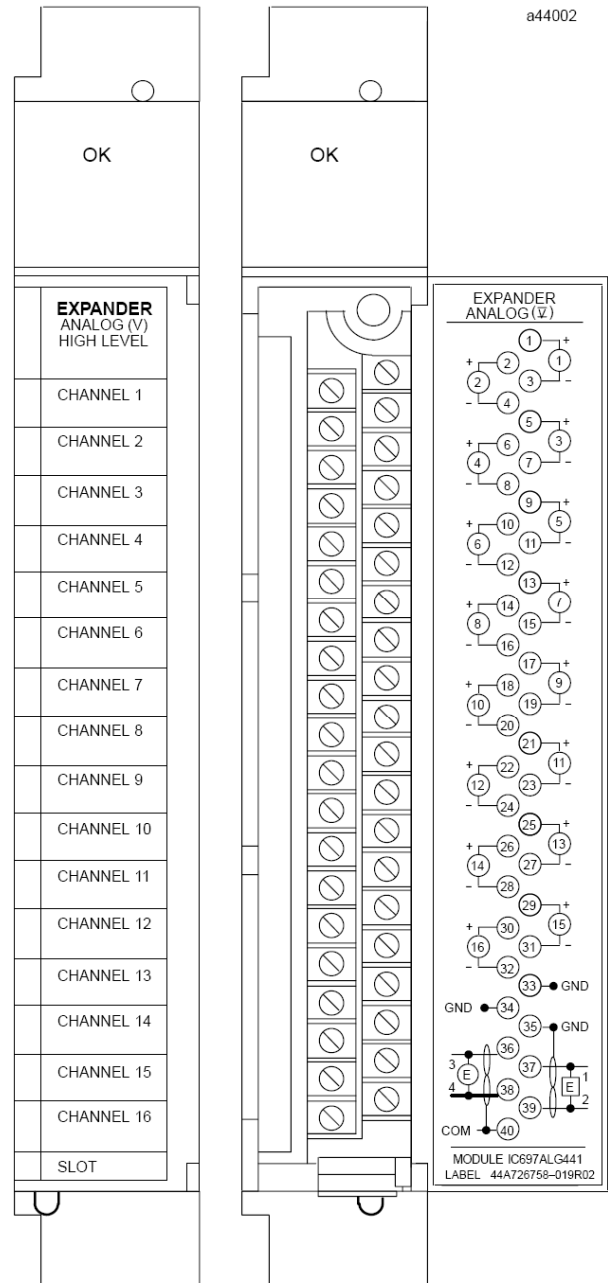

Analog Expander Module

GFK-0385G

System Operation

The following illustration is a block diagram of the High Level Analog Input system followed by an example of typical input connections.

High Level Analog Input System Block Diagram

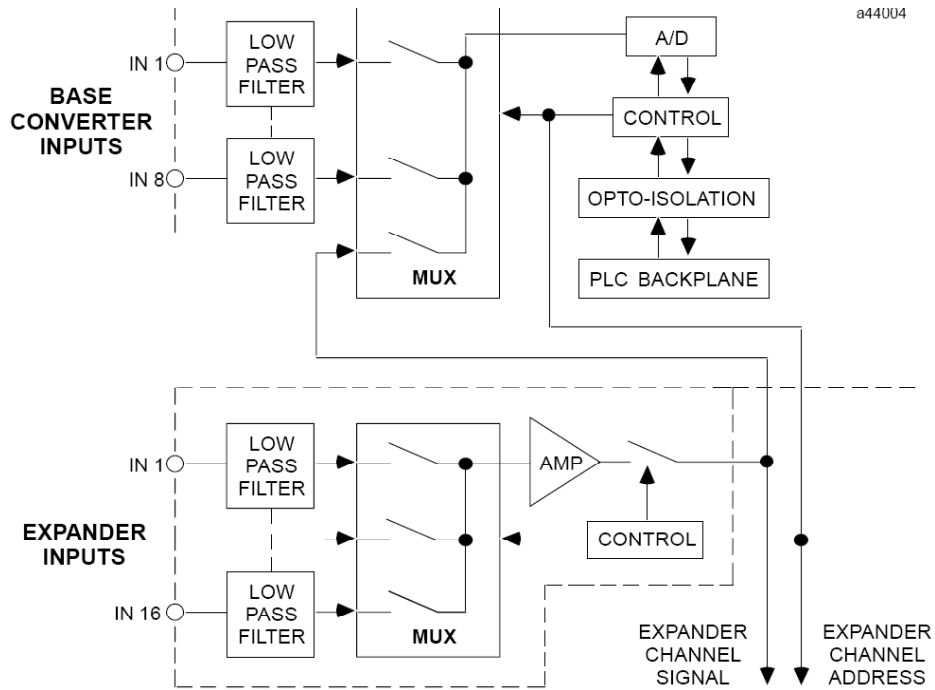

Example of Input Connections

