

# Discrete Input Modules

## IC697MDL241

GFK-0376H

July 2004

240-Volt AC, Isolated, 16-Point Input Module

### Features

- 16 isolated points
- 20ms input filter
- Proximity switch compatible

### Functions

This **240 volt AC Isolated Input** module provides 16 input points that are isolated. This allows each point to be used on a different phase of the AC supply.

The input is reactive (resistor/capacitor input) with current-voltage characteristics that meet IEC standard (type 2). The input characteristics are compatible with a large range of available proximity switches.

LED indicators that show the ON-OFF status of each point on the logic (PLC) side of the circuit are located at the top of the module.

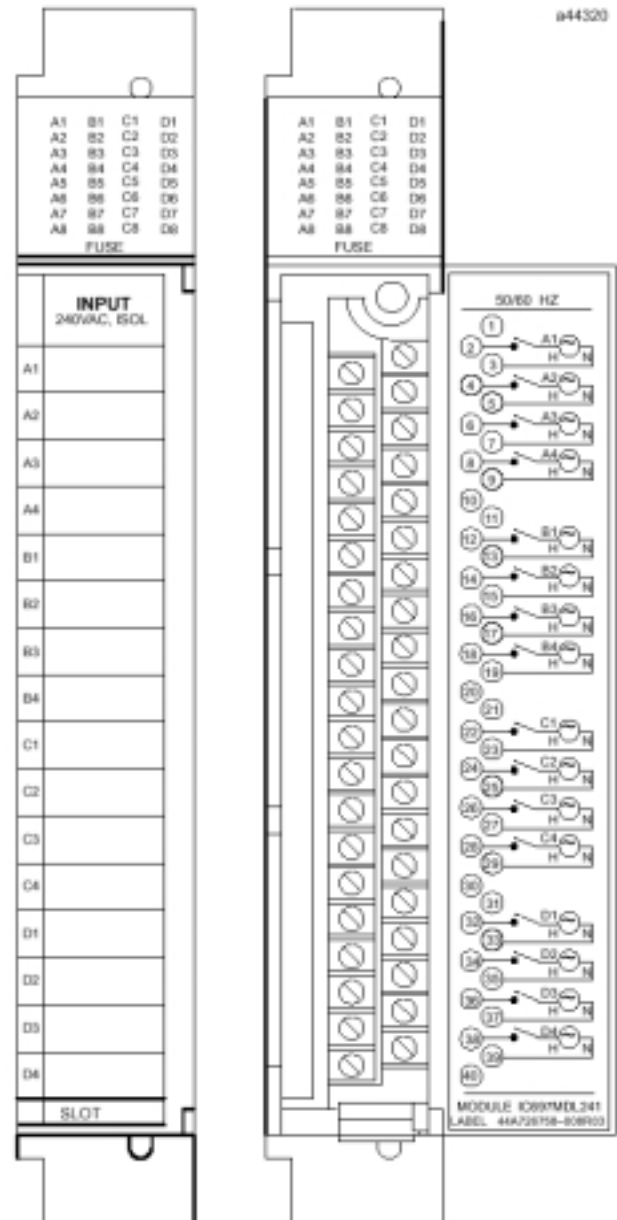

GFK-0376H  
July 2004

## Operation of the 240 VOLT AC Isolated Input Module

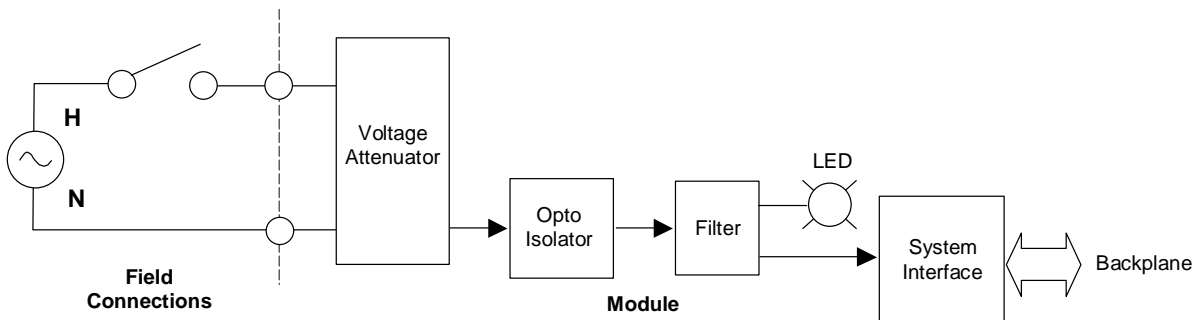

Block Diagram for IC697MDL241

### Input Characteristics

The 240 Volt AC Isolated Input Module is compatible with a wide variety of input devices, such as:

- Pushbuttons, limit switches, selector switches
- Electronic proximity switches, both 2-wire and 3-wire

The input circuitry is capacitive to give low heat dissipation and associated high reliability and long life.

Input current characteristics provide 10mA typically in the ON state, and can sink up to 2.2mA of leakage current in the OFF state to the input device.

### Proximity Switch Compatibility

This module is compatible with a wide range of both 2-wire and 3-wire proximity switches. To determine compatibility with a specific proximity switch, find the ON state characteristics of the switch in the illustration at right.

If that point falls to the left of the input load line, the ON state characteristics are compatible. As an example, the ON state requirements of a compatible proximity switch of 5mA at 20 volts drop is shown at right.

In addition, the OFF-state current must be less than 2.2mA.

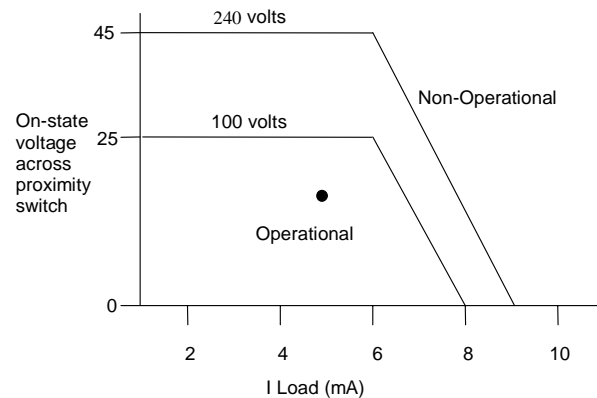

### Module Power

The 240 Volt AC Input Module 0.25 amps from the 5 volt bus on the backplane.

### Module Keying

Earlier versions of this module included a mechanical key to prevent inadvertently replacing a module with another of the wrong type. The key latched onto the backplane center rail when the module was first installed, and remained on the backplane if the module was removed.

A new module without this keying feature can be installed in a previously-keyed slot without removing the earlier keying. However, the key is easily removed by pushing it upward to unhook the latch while pulling it off the rail.

## Module Features

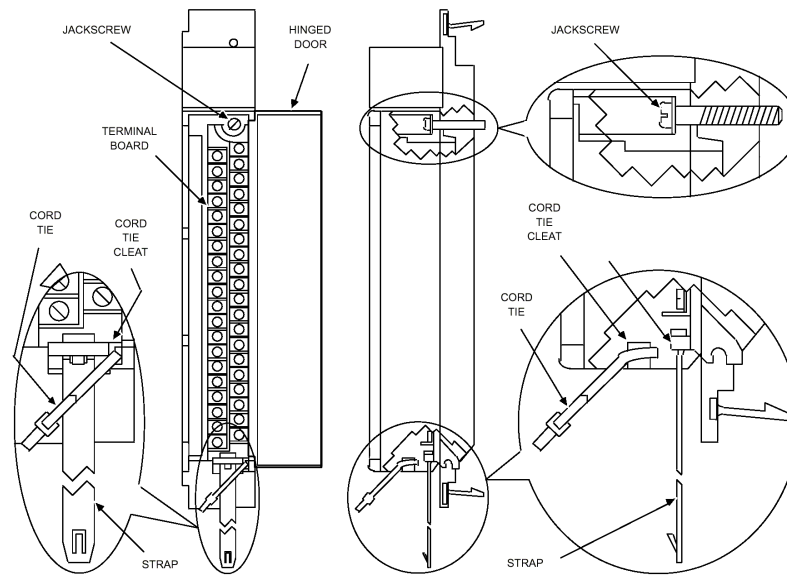

## Recommended Field Wiring Procedures

The following procedures are recommended when connecting field wiring to the detachable terminal board on this input module.

1. Turn off power before removing or installing terminal boards.
2. Open the hinged door on the module. The terminal board can be removed by turning the jackscrew counter-clockwise until it is disengaged.

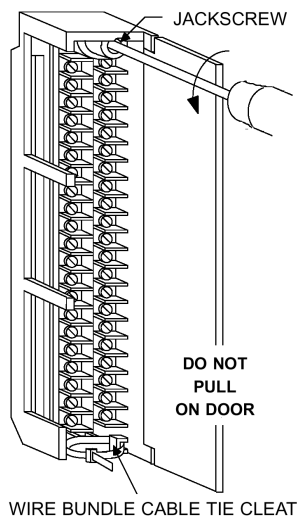

3. To remove the terminal board, grasp the top of the terminal board and swing it outward.

### Caution

**Do not use the hinged door to remove the terminal board. The door could be damaged if this is done.**

4. The terminal board accepts wire sizes from AWG #22 (0.36 mm<sup>2</sup>) through AWG #14 (2.10 mm<sup>2</sup>). When using AWG #14 (2.10 mm<sup>2</sup>) wire for wiring all points, do not exceed a maximum insulation diameter of 0.135 inch (3.43mm). To ensure proper connection, two wires may be terminated on one terminal only if both wires are the same size.
5. The terminal board accepts a maximum of 40 AWG #14 (2.10 mm<sup>2</sup>) wires. If AWG #14 (2.10 mm<sup>2</sup>) wires are used, place wire at least 8 inches (203mm) from termination end to provide space for the hinged door to close.
6. After completing connections to all modules in a rack, the wire bundle must be secured. To ensure that the wire bundle is secured properly, it is recommended that a cable tie be wrapped around the wire bundle and tightly secured through the cable tie cleat at the bottom of the terminal board. For extremely large wire bundles, additional cable ties should be used.

GFK-0376H  
July 2004

7. The module's door label shows circuit wiring information and provides space to record circuit wiring identification. A slot is provided on the hinged door to allow for insertion of this label. If the label is difficult to insert, crease the scored edge before insertion.
8. Field wiring connections are shown below. Since input is isolated from the other inputs, each input can be powered by a separate power source.



**Field Wiring Connections for IC697MDL241**

9. After field wiring is completed, fasten the terminal board to the rack by inserting the terminal board strap (attached to each module) into the small rectangular slots in the bottom card guide grill on the rack. This strap not only secures the terminal board to the rack, it also provides a way of identifying the wired terminal board with its rack slot location.
10. For adequate module ventilation, it is recommended that at least a 6 inch (152mm) clearance be allowed above and below the rack

grill. Wire bundles should not obstruct the rack grill.

**Removing an I/O Module**

The instructions below should be followed when removing an I/O module from its slot in a rack.

- Grasp the board firmly at the top and bottom of the board cover with your thumbs on the front of the cover and your fingers on the plastic clips on the back of the cover.
- Squeeze the rack clips on the back of the cover with your fingers to disengage the clip from the rack rail and pull the board firmly to remove it from the backplane connector.
- Slide the board along the card guide and remove it from the rack.

**Specifications for Module IC697MDL241**

<b>Rated Voltage</b>	240 VAC, 47 to 63 Hz Sinusoidal
<b>Inputs per Module</b>	16 individually isolated
<b>Isolation</b>	1500 volts RMS – any input to backplane 500 volts RMS between inputs
<b>Input Current:</b>	10mA (typical) at rated voltage (reactive)
<b>Input Characteristics</b>	
<b>On-state Voltage</b>	160 to 264 volts AC, 47 to 63 Hz Sinusoidal
<b>Off-state Voltage</b>	0 to 40 volts AC, 47 to 63 Hz Sinusoidal
<b>On-state Current</b>	10mA to 15mA
<b>Off-state Current</b>	0 to 5mA (2.2mA minimum at 25V input)
<b>Filter Delay Time</b>	20ms typical
<b>Current Required from 5VDC backplane bus</b>	0.25 amp

For installations requiring compliance to more stringent requirements (for example, FCC or European Union Directives), refer to GFK-1179 *Installation Requirements for Conformance to Standards*.

**Ordering Information**

<b>Description</b>	<b>Catalog Number</b>
Input Module: 240 Volt AC, 16 Points, Isolated	IC697MDL241

**Note:** For Conformal Coat option, or Low Temperature Testing option please consult the factory for price and availability.