

Chapter 1

Introduction, Description, and Specifications

This manual describes the installation and operation of the IC697VAL304, IC697VAL308, IC697VAL314, IC697VAL318, IC697VAL324, and IC697VAL328 Isolated 8-Channel 12-bit Analog Output Board with Voltage or Current Loop Outputs.

Reference Material and Other GE Fanuc Manuals

For a detailed explanation of the VMEbus and its characteristics, “The VMEbus Specification” is available from:

VITA
VMEbus International Trade Association
7825 East Gelding Dr., No. 104
Scottsdale, AZ 85260
(480) 951-8866
FAX: (480) 951-0720
Internet: www.vita.com

The following Application and Configuration Guides are available from GE Fanuc to assist in the selection, specification, and implementation of systems based upon GE Fanuc’s products:

Analog I/O Products (Built-in-Test) Configuration Guide (catalog number GFK-2084)	Provides assistance in configuring analog I/O subsystems based on GE Fanuc’s analog I/O products, including common designs, which offer a wide variety of solutions.
Connector and I/O Cable Application Guide (catalog number GFK-2085)	Describes I/O connections that can be used with GE Fanuc’s VMEbus products. Includes connector compatibility information and examples.

General Description

The Analog Output Board provides eight isolated high quality 12-bit analog output channels on a single 6U form factor VMEbus board. Each channel is electrically isolated from all other channels and from the VMEbus.

Listed below are some features of the Analog Output Board:

- Eight fully isolated analog outputs
- 1,500 Vpk isolation, channel-to-channel and channel-to-bus
- 12-bit resolution
- Bipolar voltage output ranges selectable as ± 2.5 , ± 5 , or ± 10 V
- Unipolar voltage output ranges selectable as 0 to 2.5 V, 0 to 5 V, or 0 to 10 V
- 10 mA load capacity for voltage outputs over full ± 10 V range
- Available with 4 to 20 mA current loop outputs
- 0.05 percent accuracy for voltage outputs, 0.08 percent for current loop outputs
- Four or eight-channel options
- Optical data coupling provides full galvanic isolation
- Static readback data registers simplify program control
- Front panel access for field connections
- Program-controlled connect/disconnect operation of voltage outputs facilitates system testing

Functional Description

The Analog Output Board internal organization is illustrated in the functional block diagram shown in Figure 1-1 on page 1-4. The board will operate with sustained isolation voltages as high as 1,500 Vpk. Bipolar output voltage ranges are selectable as ± 2.5 V, ± 5 V, or ± 10 V. Unipolar output voltage ranges are selectable as 0 to 2.5 V, 0 to 5 V, or 0 to 10 V, and full 10 mA loading is supported throughout these ranges. Four or 8-channel configurations are available.

Voltage outputs may be disconnected under program control during system testing, and are disconnected automatically during reset. Current-mode outputs support applications that require standard 4 to 20 mA analog current loops. Compliance of the current mode outputs is 9 V if the loop supply originates on the board, or 27 V with an external loop power supply. A front panel LED (Fail) is provided. The LED is illuminated during power up or system reset and can be turned OFF under user software control.

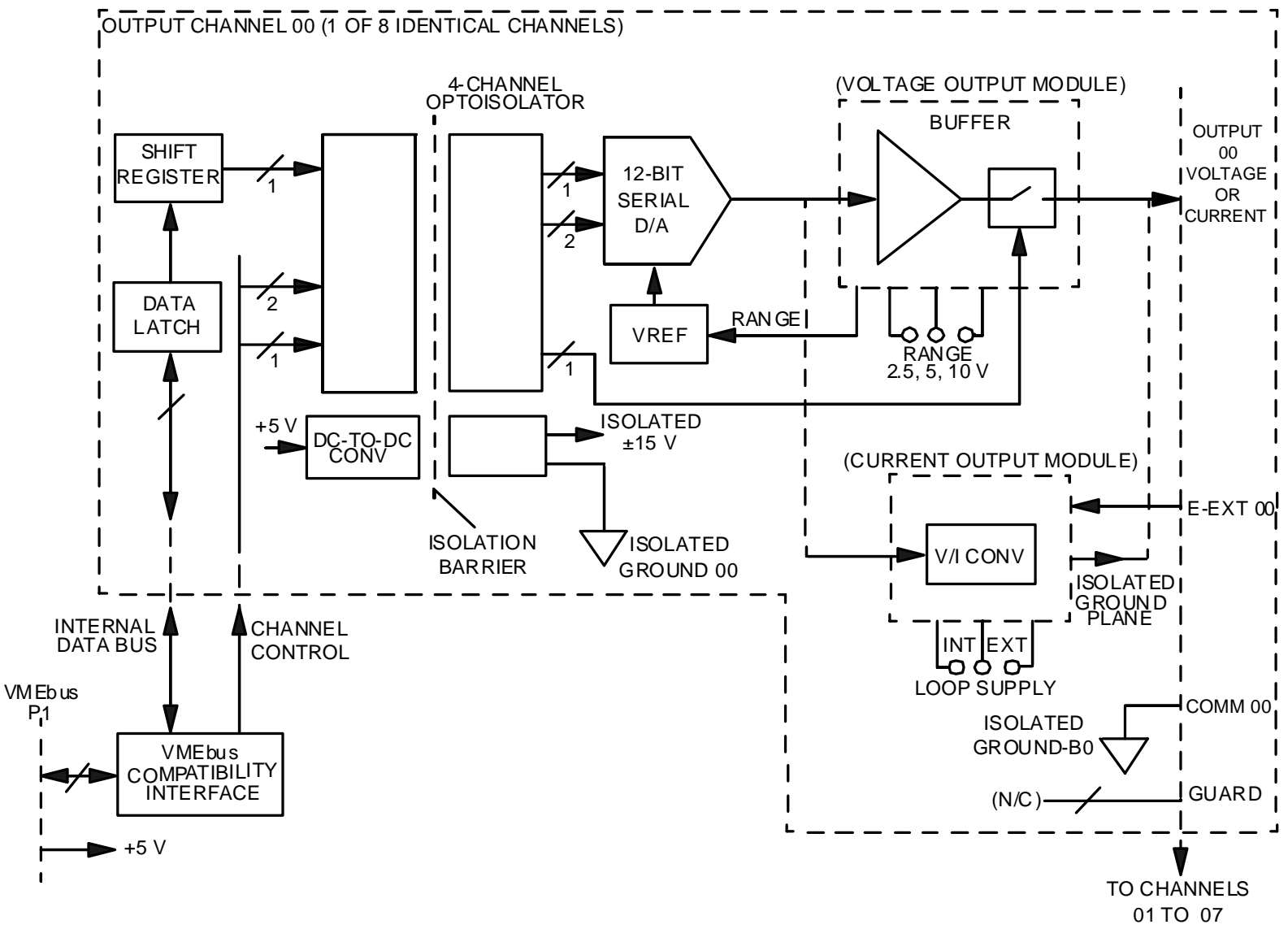

Figure 1-1: Analog Output Board Functional Block Diagram