

Analog Voltage Input - 16 Channel IC693ALG222

The *16-Channel Analog Voltage Input* module provides up to 16 single-ended or eight differential input channels, each capable of converting an analog input signal to a digital value for use as required by your application. This module provides two input ranges:

- 0 to 10 V (unipolar)
- -10 to +10 V (bipolar)

Voltage Ranges and Input Modes

The default input mode and range is single-ended, unipolar, with the user data scaled so that 0 volts corresponds to a count of 0 and 10 volts corresponds to a count of +32000. The other range and mode are selected by changing the configuration parameters using the Logicmaster 90-30/20/Micro or CIMPLICITY Control configurator software, or the Hand-Held Programmer. The range can be configured for bipolar -10 to +10 V where -10 V corresponds to a count of -32000, 0 V corresponds to a count of 0, and +10 V corresponds to a count of +32000.

High and Low alarm limits are available on all ranges. Ranges can be configured on a per channel basis.

Power Requirements and LEDs

This module consumes a maximum of 112 mA from the 5V bus on the PLC backplane. It also requires a maximum of 41 mA from the backplane Isolated+24 Volt DC supply to power the on-board power converter that provides isolated ± 5 V supplies to power the user-side circuitry (see Table 3-9, *Specifications*).

There are two green LED indicators on the module which provide module and user supply status. The top LED, **MODULE OK** provides module status information on power-up as follows:

- *ON*: status is OK, module configured
- *OFF*: no backplane power or software not running (watchdog timer timed out)
- *Continuous rapid flashing*: configuration data not received from CPU
- *Slow flashes, then OFF*: failed power-up diagnostics or encountered code execution error

The bottom LED, **Power Supply OK**, indicates that the internally generated user-side +5V supply is above a minimum designated level.

Location in System

This module can be installed in any I/O slot of a 5 or 10-slot baseplate in a Series 90-30 PLC system.

References Used

The number of 16-Channel Analog Voltage Input modules which may be installed in a system depends on the amount of %AI and %I references available. Each module uses 1 to 16 %AI references (depending on the number of channels enabled) and from 8 to 40 %I references (depending on alarm status configuration).

The available %AI references are: 64 with CPUs 311, 313, and 323; 128 with CPU331; 1024 with CPUs 340 and 341; and 2048 with CPUs 350 – 364.

The maximum number of 16-Channel Analog Voltage Input modules which may be installed in a system are:

- 4 in a system using CPUs 311, 313, or 323
- 8 in a system using CPU331
- 12 in a system using CPUs 340 or 341
- 51 in a system using CPUs 350 – 364

When planning the module configuration for your application you must also consider the load capacity of the installed power supply and the total load requirements of all modules that are installed in the baseplate.

Refer to the *Series 90-30 Programmable Controller Installation Manual*, GFK-0356 for details on power supplies and module load requirements.

Table 10-3. Specifications for 16-Channel Analog Voltage Input Module, IC693ALG222

Number of Channels	1 to 16 selectable, single-ended 1 to 8 selectable, differential
Input Current Ranges	0V to +10V (unipolar) or -10V to +10V (bipolar); selectable each channel
Calibration	Factory calibrated to: 2.5 mV per count on 0V to +10V (unipolar) range 5 mV per count on -10 to +10V (bipolar) range
Update Rate	6 msec (all 16 single-ended channels) 3 msec (all 8 differential channels)
Resolution at 0V to +10V	2.5 mV (1 LSB = 2.5 mV)
Resolution at -10V to +10V	5 mV (1 LSB = 5 mV)
Absolute Accuracy ‡	± 0.25% of full scale @ 25°C (77°F) ± 0.5% of full scale over specified operating temperature range
Linearity	< 1 LSB
Isolation	1500 volts between field side and logic side
Common Mode Voltage (Differential)	± 11V (bipolar range) †
Cross-Channel Rejection	> 80 db from DC to 1 kHz
Input Impedance	>500K ohms (single-ended mode) >1M ohms (differential mode)
Input Filter Response	41 Hz (single-ended mode) 82 Hz (differential mode)
Internal Power Consumption	112 mA (maximum) from the backplane +5 VDC bus 41 mA (maximum) from the backplane Isolated +24 VDC supply

Refer to Appendix B for product standards and general specifications.

† The summation of the differential input, common-mode voltage, and noise must not exceed ±11 volts when referenced to COM.

‡ In the presence of severe RF interference (IEC 801-3, 10V/m), accuracy may be degraded to ±5% FS.

CPU Interface to the IC693ALG 222 Analog Voltage Input Module

The Series 90-30 PLC uses the data within the %AI data table to record analog values for use by the programmable controller. This scheme for the 16-Channel Analog Voltage Input module is shown below. More information on the CPU interface to analog modules can be found at the beginning of this chapter.

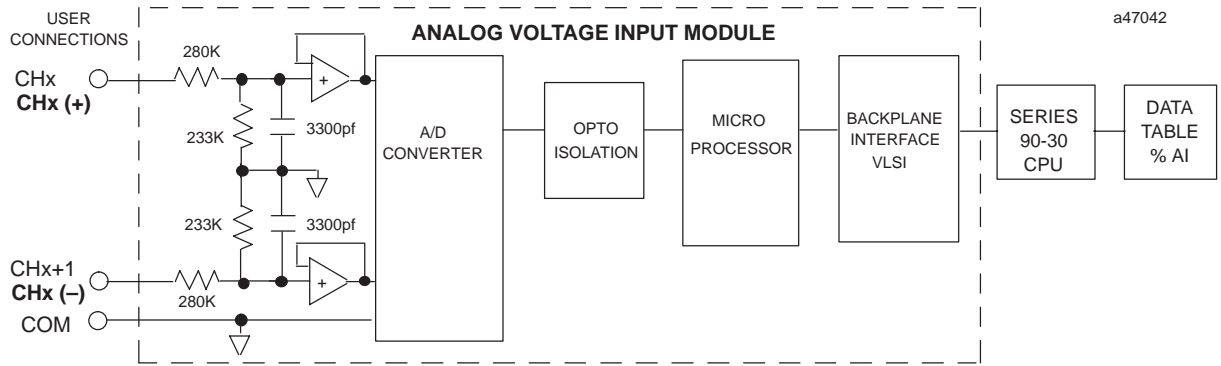

NOTE: CHx AND CHx+1 INDICATE SINGLE-ENDED MODE; CHx (+) AND CHx (-) INDICATE DIFFERENTIAL MODE

Figure 10-9. 16-Channel Analog Voltage Input Module Block Diagram - IC693ALG222

Placement of A/D Bits within the Data Tables

Since converters used in the analog modules are 12-bit converters, not all of the 16 bits in the data tables contain data required for the conversion. A version of the 12 bits is placed within the 16-bit data word corresponding to the analog point (in the %AI table). The Series 90-30 PLC system handles the integration differently for the various analog modules.

The CPU does not manipulate the data from the input modules before placing it within the word in the %AI data table. The bits in the %AI data table which were not used in the conversion by the input module are either forced to 0 (zero) by the analog input module. Placement of the 12 data bits from the A/D converter for an analog current input data word for the 16-Channel Analog Voltage Input module in unipolar range is shown below.

MSB												LSB			
X	D11	D10	D9	D8	D7	D6	D5	D4	D3	D2	D1	D0	X	X	X

X=not converted bits

Analog values are scaled over the range of the converter. Factory calibration adjusts the analog value per bit (resolution) to a multiple of full scale (that is, 2.5 mV/bit for unipolar; 5 mV/bit for bipolar). This calibration leaves a normal 12-bit converter with 4000 counts (normally $2^{12} = 4096$ counts). The data is then scaled with the 4000 counts over the analog range. For example, the data to the A/D converter for the 16-Channel Analog Voltage Input is scaled as shown below.

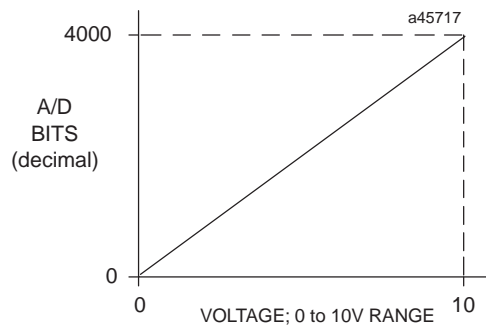

Figure 10-10. A/D Bits vs. Voltage Input for IC693ALG222

IC693ALG222 Analog Module Field Wiring Connections

Connections to this module from user devices are made to screw terminals on a removable 20-terminal connector block mounted on the front of the module. The actual terminals used are described in the following table and are shown in the following wiring diagrams.

Terminal Assignments

Pin assignments for the 20 terminal I/O connector on the 16-Channel Analog Voltage Input module are as shown in the following table.

Table 10-4. Terminal Pin Assignments for IC693ALG222

Pin Number	Signal Name	Signal Definition
1	n/a	not used
2	n/a	not used
3	CH1	Single Ended Channel 1, Differential Channel 1 (Positive terminal)
4	CH2	Single Ended Channel 2, Differential Channel 1 (Negative terminal)
5	CH3	Single Ended Channel 3, Differential Channel 2 (Positive terminal)
6	CH4	Single Ended Channel 4, Differential Channel 2 (Negative terminal)
7	CH5	Single Ended Channel 5, Differential Channel 3 (Positive terminal)
8	CH6	Single Ended Channel 6, Differential Channel 3 (Negative terminal)
9	CH7	Single Ended Channel 7, Differential Channel 4 (Positive terminal)
10	CH8	Single Ended Channel 8, Differential Channel 4 (Negative terminal)
11	CH9	Single Ended Channel 9, Differential Channel 5 (Positive terminal)
12	CH10	Single Ended Channel 10, Differential Channel 5 (Negative terminal)
13	CH11	Single Ended Channel 11, Differential Channel 6 (Positive terminal)
14	CH12	Single Ended Channel 12, Differential Channel 6 (Negative terminal)
15	CH13	Single Ended Channel 13, Differential Channel 7 (Positive terminal)
16	CH14	Single Ended Channel 14, Differential Channel 7 (Negative terminal)
17	CH15	Single Ended Channel 15, Differential Channel 8 (Positive terminal)
18	CH16	Single Ended Channel 16, Differential Channel 8 (Negative terminal)
19	COM	Common connection for Single Ended Channels
20	GND	Frame ground connections for cable shields

IC693ALG222 Analog Input Module Field Wiring Diagrams

The following figures provide information for connecting field wiring to the user terminal board on the 16-Channel Analog Voltage Input Module.

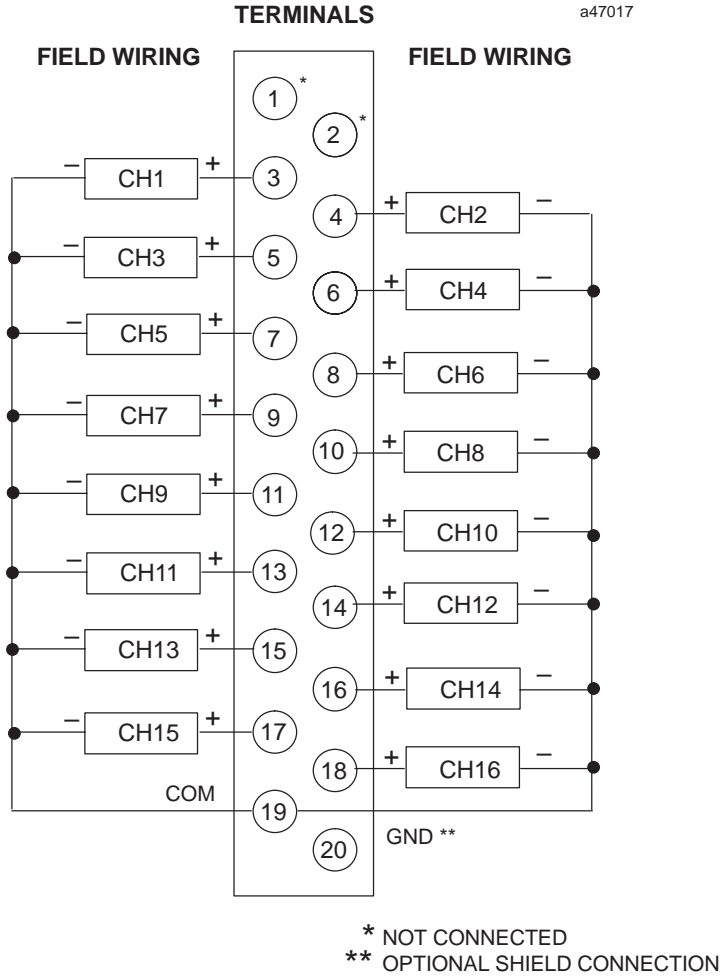

Figure 10-11. Field Wiring for 16-Channel Analog Voltage Input Module - IC693ALG222 (Single-Ended Mode)

Note

Please refer to Chapter 2 for wiring and shield ground connection details.