

5.5 Converter control ITDC

Order No. 6DD1601-0AH0
Description The ITDC expansion module corresponds to the earlier PG16 module, and provides the gating (control) for

- line-commutated drive converters.

It includes:

- Auto-reversing stage
- Current controller
- Gating unit (for max. 400 Hz output frequency)
- For 6-pulse drive converters

It is especially suitable for connection to SITOR power sections.

The expansion module is inserted on a CPU module (PM5, PM6). A maximum of 2 expansion modules ITxx can be inserted on a CPU module. One ITxx occupies 1 slot (in addition to the slot in the CPU module). Presently, the operation of 2 ITDC modules in one processor module is not supported.

Inputs and outputs

- 1 SITOR interface
- 2 analog outputs
- 4 binary outputs
- 4 binary inputs
- 1 incremental encoder input:
 - With zero pulse
 - Optionally, for differential signals
 - For tracks, shifted through 90 degrees (A, B)
 - For 15 V (HTL)- or 5 V encoders
 - Max. 1 MHz pulse frequency
- No electrical isolation of the inputs-/outputs

Incremental encoder setting

Incremental encoders can be connected to the ITDC, with the following signal voltages

- 15V
- 5V (also as push - pull signals and RS485 differential signals)

The incremental encoder type is selected using DIL switch S1 on the component side of the ITDC (refer to the following diagram).

There is the following assignment of the DIL switch settings S1.X to the pulse encoder channels :

Switch	Switch setting	Function
S1.1	ON	Track A, zero volt switching threshold f. 5V encoders
S1.1	OFF	Track A, 7V switching threshold f. 15V encoders
S1.2	ON	Track B, zero volt switching threshold f. 5V encoders
S1.2	OFF	Track B, 7V switching threshold f. 15V encoders
S1.3	ON	Zero pulse, 0V switching threshold f. 5V encoders
S1.3	OFF	Zero pulse, 7V switching threshold f. 15V encoders
S1.4	any	none

Corresponding to the setting of the switch on S1, either select the 15V 3-phase encoder (7V switching threshold) or 5V 3-phase encoder (0V switching threshold).

For the **factory setting**, the switch is in the OFF position for 15V 3-phase encoders.

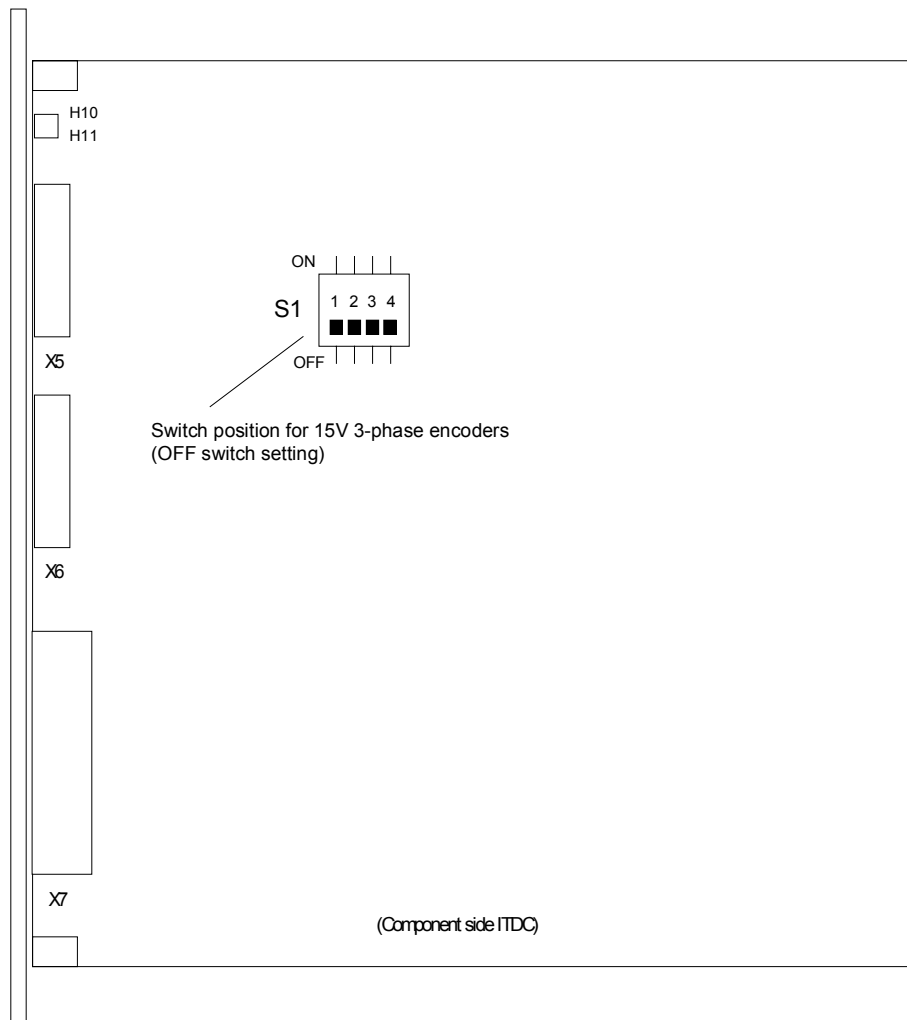

Fig. 5-10 Switch position for incremental encoders

Block diagram

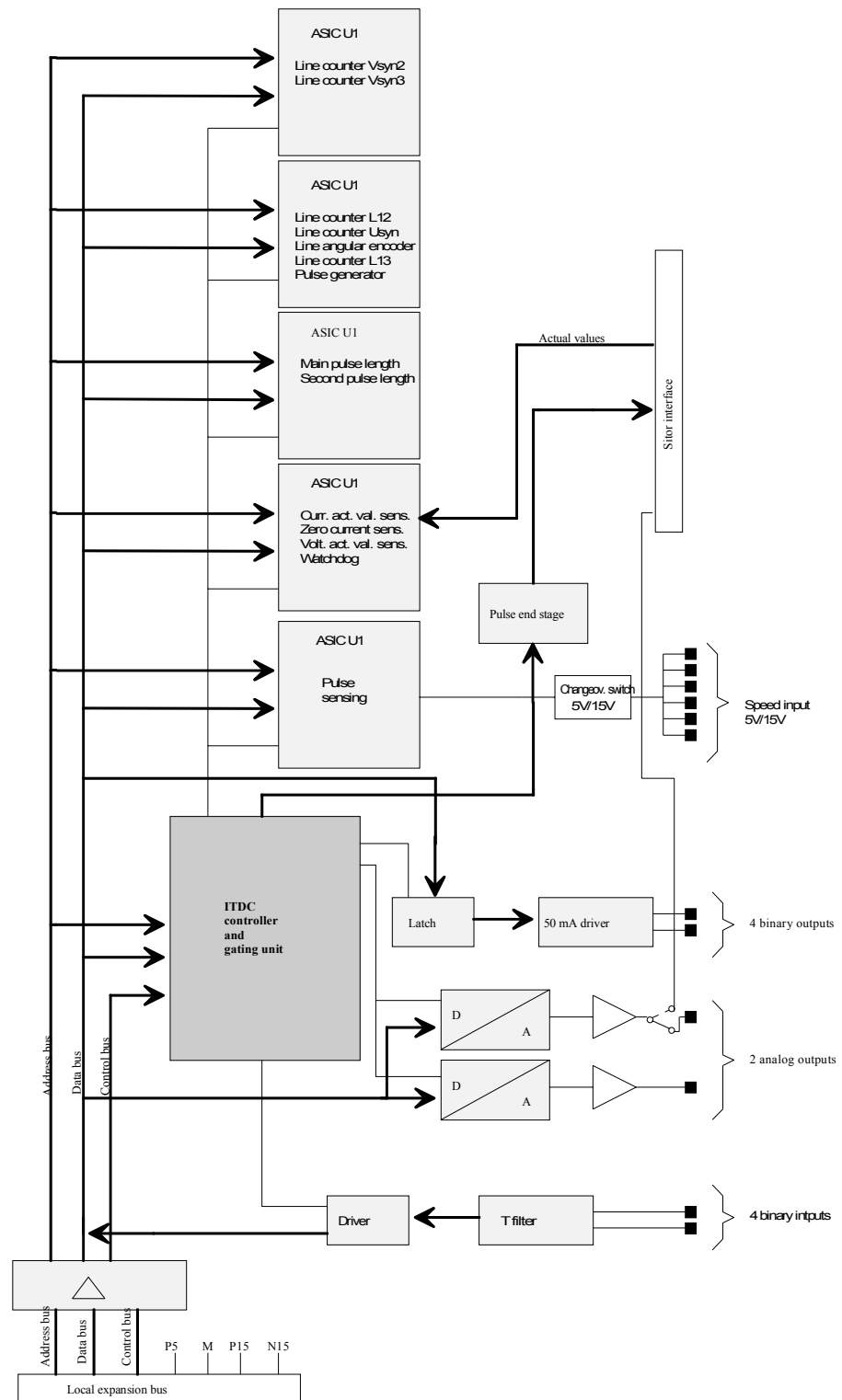

Fig. 5-11 Block diagram ITDC

5.5.1 Supplementary components

Interface modules with terminals

All of the input / output signal cables are not directly connected to the module, but are connected through interface modules. The interface modules serve as mechanical connecting elements (**screw plug-in terminals**), and to electrically adapt the plant /system signals and convert them (optional).

Interface-module	Function
SB10	Direct connection (1:1 connection) from 8 binary inputs /outputs, LED, no signal conversion
SB60	8 binary inputs , 230V to 24V conversion (signal level of the module), LED, electrical isolation
SB61	8 binary inputs , 48V to 24V conversion, LED, electrical isolation
SB70	8 binary outputs , 24V to 230V conversion (changeover relay), LED, electrical isolation
SB71	8 binary outputs , 25V to 48V conversion (transistor)
SU11	20 signals can be directly connected, no signal conversion

Table 5-38 Interface modules which can be connected to the module

Cables

The module is connected to the interface modules using plug-in cables. Pre-assembled cables are available for the SU11 interface module.

Interface modules either with or without signal conversion (e.g. signal level conversion, electrical isolation) and LED display can be used at connector X5 with binary inputs and outputs.

Pre-assembled cables are not available for the SB10, SB60, SB61, SB70 and SB71 interface modules in conjunction with the ITDC.

Conn., ITDC	Signals	Cable	Interface module
X5	Analog outputs SITOR start-up signals	SC12	1 x SU11
X6	Binary inputs /outputs and speed sensing	SC12 - - - - -	1 x SU11 or SB10 SB60 SB61 SB70 SB71 SU12

Table 5-39 Cables which can be used together with the modules

5.5.2 Connector assignment X5

Connector X5 (20-pin plug connector) connects signals for

- 2 analog outputs
- SITOR start-up signals

The **SU11** interface module can be connected via **SC12** plug-in cable (1:1-connection from the module to the terminals):

SU11 analog outputs and start-up signals via the SC12 cable

ITDC X5 Pin	Designation	SU 11 X2	Connector designation for configuring
1	Analog output 1+	1	X5A
2	Ground, analog output 1	2	
3	Analog output 2+	3	X5B
4	Ground, analog output 2	4	
5	External synchronizing voltage, L1 for 3-phase synchronization	5	
6	Reference voltage for the synchronizing voltage	6	
7	P15 output, 15V ($R_i = 600 \text{ ohm}$, not suitable to supply the encoders)	7	
8	Measuring signal "Zero crossover of the SITOR power supply phase voltage" L13	8	
9	Display, zero crossover signal identification, synchronizing voltage Logic signal level 15V, $R_i = 2.2K \text{ ohm}$ for an "H" signal	9	
10	External pulse inhibit, if connected to pin 7 or 24V -> pulses enabled	10	
11	Excitation current setpoint, 0..10V, $R_i = 2.2K \text{ ohm}$	11	
12	Measuring signal "Summed pulses"	12	
13	Analog current actual value +/-10V, $R_i = 2.2K \text{ ohm}$	13	
14	Ground (digital), reference potential for measuring signals	14	
15	Measuring signal, "Total pulse inhibit", pulses enabled = 5V	15	
16	Ground, synchronizing module	16	
17	Synchronizing voltage U12 for 3-phase synchronization	17	
18	Synchronizing voltage U23 for 3-phase synchronization	18	
19	Synchronizing voltage U31 for 3-phase synchronization	19	
20	Pulse chain synchronizing, connected with additional PG11/PG16 or ITDC "H" output voltage: 10-14V "H" output current: 40mA	20	

Table 5-40 Pin assignment ITDC, connector X5 and terminal assignment SU11,

5.5.3 Connector assignment X6

Connector X6 (20-pin plug connector) connects the signals for:

- 4 binary inputs
- 4 binary outputs
- 1 speed input

The **SU11** interface module can be connected via the **SC12** plug-in cable (1:1 connection from the module to the terminals):

SU11 binary input/output and speed sensing via cable SC12

ITDC X6 Pin	Designation	SU 11 X2	Connector designation for configuring
1	Binary input 1	1	X6A
2	Binary input 2	2	
3	Binary input 3	3	
4	Binary input 4	4	
5	Binary output 1	5	X6G
6	Binary output 2	6	
7	Binary output 3	7	
8	Binary output 4	8	
9	P _{ext} , positive power supply, max. 30 V	9	
10	M _{ext} , 0V power supply	10	
11	Speed sensing, track 1A-	11	X6C
12	Speed sensing, track 1A+	12	
13	Speed sensing, track 1B-	13	
14	Speed sensing, track 1B+	14	
15	Speed sensing, zero pulse 1N-	15	
16	Speed sensing, zero pulse 1N+	16	
17	Coarse pulse	17	
18	GND ext.	18	
19	GND ext.	19	
20	n. c.	20	

Table 5-41 Pin assignment ITDC, connector X6 and terminal assignment SU11

5.5.4 Connector assignment X7

Connector X7 (sub-D 50-pin) connects the signals to control (gate) a SITOR set (three-phase bridge).

Via plug-in cable:

- **SC17.2** (screened round cable, 50-pin SUB-D, 2m long), or
- **SC31.2** (screened round cable, 50-pin SUB-D, 10m long)

The module can be directly connected to a SITOR set.

SITOR signals

ITDC X7 Pin	Designation	Connector designation for configuring
1	Screen	X7G
2	Screen	
3	Fuse monitoring (fault = "L")	
4	Screen	
5	Zero crossover (L1-L3)	
6	Screen	
7	+/- I_{act} frequency: 60KHz +/- 30KHz corresponds to +/- 2 I_N	
8	Reference voltage, excitation current setpoint	
9	M24 external	
10	Pulse. 1.6	
11	M24 external	
12	Pulse 1.3	
13	Screen	
14	M24 external	
15	Pulse 2.4	
16	M24 external	
17	Pulse 2.1	X7G
18	V_{SYN} (synchronizing voltage) neutral point	
19	Excitation current monitoring (fault = "H") $I_{E_act} < 3,3 \%$, $I_{E_N} = "H"$	
20	Temperature monitoring (fault = "L")	
21	Screen	
22	+/- V_{Alst} frequency 60KHz +/- 30KHz corresponds to +/- V_{AN}	
23	Screen	
24	+/- I_{act} analog +/-10V corresponds to +/- I_N (only when connecting a SITOR set, for SE20.1--> 2P24)	
25	Screen	
26	M24 external	
27	Pulse 1.4	
28	M24 external	
29	Pulse 1.1	
30	Pulse 2.2	
31	M24 external	
32	Pulse 2.5	
33	M24 external	
34	V_{SYN} (L1)	
35	Undervoltage monitoring (fault = "L")	
36	Screen	
37	Zero crossover (L1-L2)	

ITDC X7 Pin	Designation	Connector designation for configuring
38	Screen	
39	I = 0 signal (I = 0 corresponds to "H")	
40	Screen	
41	Excitation current setpoint I _{E_N_S} (Feldsteller) corresponds to 10 V	
42	Pulse 1.2	
43	M24 external	
44	Pulse 1.5	
45	M24 external	
46	M24 external	
47	Pulse 2.6	
48	M24 external	
49	Pulse 2.3	
50	Screen	

Table 5-42 Pin assignment ITDC, connector X7 SITOR signals

5.5.5 Technical data

General data

Insulation group	A according to VDE 0110 § 13 Group 2 for 24 V DC, 15 V DC, 5 V DC
Ambient temperature	0 to +55 degrees C and fan operation (force ventil.)
Storage temperature	-25 to +70 degrees C
Humidity rating	F according to DIN 40050
Altitude rating	S according to DIN 40040
Mechanical rating	Installed in stationary equipment, which is not necessarily vibration-free
Packaging system	ES 902 C
Dimensions	233.4 mm * 220 mm
Module width	20.14 mm
Installation size	1 slot
Weight	600 g

Power supply

Rated voltage	min.	max.	Typ. current drain
+5 V	+4.75 V	+5.25 V	100 mA
+15 V	+14.4 V	+15.6 V	490 mA (+ encoder load)
-15 V	-15.6 V	-14.4 V	75 mA
24 V (external)	+15V	+30 V	70 mA (+ load of the binary outputs)

Analog outputs, connector X5

No.	2
Version	Output with associated ground, non-floating
Output voltage range	-10 V to +10 V
Output current	+/- 10 mA
Resolution	12 bits
Monotony	10 bits over the complete temperature range
Absolute accuracy	Typ. 9 bits over the complete temperature range
Short-circuit protection to ground	Yes

Binary inputs connector X6

No.	4 non-floating	
Input voltage	24 V DC rated voltage	
	For 0 signal	-1 V to +6 V or inputs open-circuit
	For 1 signal	+13 V to +33 V
Input current		
	For 0 signal	0 mA
	For 1 signal	3 mA typ.
Delay time	120 µs	

Binary outputs connector X6

No.	4, non-floating
Supply voltage	Must be supplied externally
Nominal value	24 V DC
Permiss. range	+20 V to 30 V, including ripple
Briefly	+35 V, max. 0.5 s
Output current for 1 signal	
Rated current	50 mA
Permiss. range	To 50 mA
Short-circuit protection	Electronic (thermal)
Limiting inductive switch-off voltages	+ 1 V power supply voltage
Total load	80 % at 50 degrees C, all outputs 50 mA
Residual current	20 µA for a 0 signal
Signal level	
For 0 signal	Max. 3 V
For 1 signal	- 2.5 V power supply voltage
Switching delay	1->0: max. 10 µs 0->1: max. 100 µs

Incremental encoders

No. of encoders	1, non-floating
Version	Differential inputs without electrical isolation, can be changed over between 5V/15V(HTL)
Track signals	Tracks A and B (phase shifted through 90 degrees), if required with zero pulse N
Pulse frequency	Max. 1 MHz (track frequency)
Phase difference of the track signals	Independent of the pulse frequency, min 200 ns
Input voltage for 15V (HTL)	
For 0 signal	-30 V to +5 V
For 1 signal	+8 V to + 30 V
Input voltage for 5V	
For 0 signal	-7 V to -1.5 V
For 1 signal	+1.5 V to + 7 V
Permissible input voltage range	Differential voltage, -30 V to +30 V
Input resistance	Approx. 40K
Fault pulse suppression	Can be configured at the speed actual value function block: 0 - 16 µs (62.5 kHz)

The module does not provide a power supply for the encoder.

5.5.6 Mounting/Installation

When mounted outside the subrack, the ITxx module is inserted on a CPU module PMx or on an ITxx module, already mounted on PMx (using a 96-pin plug connector on the module).

Spacers

All of the modules must be screwed to one another using the spacers provided (3 spacers)!

For the first ITxx

The first ITxx, mounted directly on a CPU module, must be retained using the **metal spacers** (these are included with the PMx). The electrical contact which is established is required to identify the first expansion module. The metal spacers are attached to the PMX using the M3 screws provided together with the washers and spring washers.

For a second ITxx

If only **one ITxx** module is used, it can be screwed to the metal spacers using the M4 nuts (and washers) provided.

If a second ITxx module is used, the first ITxx module is not screwed using the nuts, but instead, using **plastic** spacers (these are included with the ITxx modules).

The second ITxx module can then be inserted on the **plastic** spacers, and screwed together using the M4 nuts (and washers).

After the module assembly has been screwed together, it is inserted into the subrack.

5.5.7 Application information and noise immunity

- Operation **without** fans is possible
- Noise immune operation is only possible, if it is tightly screwed into the subrack.

Other information

For more detailed information on EMC and the ambient conditions, refer to the "General technical data" section!

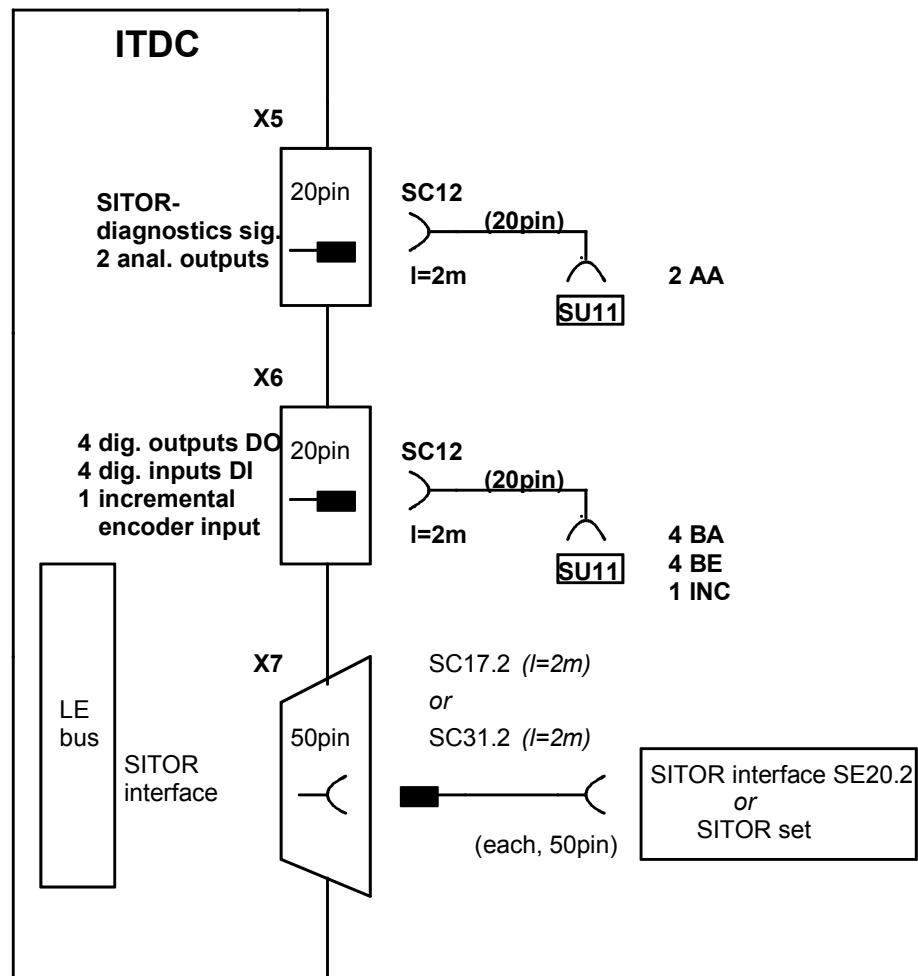
5.5.8 Connecting diagrams

Fig. 5-12 Connecting cables and interface modules