



AC (12-120V) Output Module

Cat. No. 1771-OAD Series B

Installation Instructions

To The Installer

This document provides information on:

- important pre-installation considerations
- power supply requirements
- installing the module
- using the indicators for troubleshooting
- replacing the fuse
- module specifications

Pre-installation Considerations

The 1771-OAD Series B module is compatible with all chassis except 1771-A1, 1771-A2 and 1771-A4 chassis. Make sure no other output module or single card block transfer module is placed in the same module group when using 2-slot addressing. Any discrete input module may be used within the same module group.

Power Requirements

Your module receives its power through the 1771 I/O chassis backplane from the chassis power supply. The module requires 295mA from the output of this supply. Add this to the requirements of all other modules in the I/O chassis to prevent overloading the chassis backplane and/or chassis power supply.

Initial Handling

The ac output module is shipped in a static-shielded bag to guard against electrostatic discharge damage. Observe the following precautions when handling the module.

Electrostatic Discharge Damage



ATTENTION: Under some conditions, electrostatic discharge can degrade performance or damage the module. Observe the following precautions to guard against electrostatic damage.

- Wear an approved wrist strap grounding device, or touch a grounded object to discharge yourself before handling the module.
- Do not touch the backplane connector or connector pins.

Installation Instructions

AC (12–120V) Output Module
Cat. No. 1771-OAD Series B

Installing Your Module

- If you configure or replace internal components, do not touch other circuit components inside the module. If available, use a static-free work station.
- When not in use, keep the module in its static-shielded bag.

In this section we tell you how to:

- change the mode of the fuse-blown jumper
- key your I/O chassis
- install your module
- make your wiring connections

Changing the Mode of the Fuse-blown Jumper

The fuse-blown jumper has two modes:

- the preset, **standard (STD) mode** – displays the fuse status on the red fuse-blown status indicator
- the **customer side indication (CSI) mode** – displays the fuse status in the input image table **and** on the red fuse-blown status indicator. This mode configures the module as a 16 point output module that utilizes **both the output and input image data tables** of your controller. When a fuse blows, all 16 bits in the associated input image table will turn on (1).
For example, if you install the module in a PLC-5 system and address the module as O:012, then the fuse status bits are in I:012.

To monitor the status of the module fuse, make certain that your user program monitors the module's input image table for “on” bits.

Important: Do not put the module jumper in CSI mode when you use this module in a complementary mode. Your system will not operate properly.

To change the fuse blown jumper to the CSI mode, do the following:

1. Locate the fuse-blown jumper at the top-right edge of the module circuit board, as shown in the following figure.
2. Use your finger to slide the jumper off the STD position (the middle post and the left post).
3. Carefully reposition the jumper by sliding it onto the CSI position (the middle post and the right post).

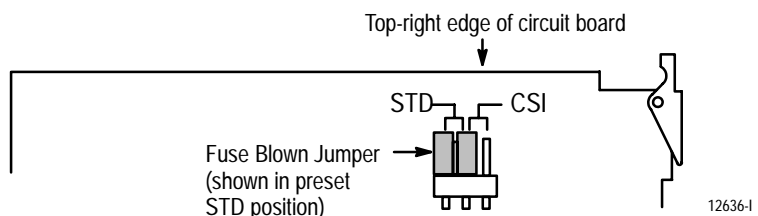

Keying Your I/O Chassis

Use the plastic keying bands, shipped with each I/O chassis, to key the I/O slots to accept only this type of module.

The module circuit board is slotted in two places on the rear edge. The position of the keying bands on the backplane connector must correspond to these slots to allow insertion of the module. You can key any connector in an I/O chassis to receive this module except for the left-most connector reserved for adapter or processor modules. Place keying bands between the following numbers labeled on the backplane connector:

- Between 10 and 12
- Between 20 and 22

You can change the position of these keys if system redesign and rewiring makes insertion of a different module necessary.

Installing the Output Module

To install the ac output module in your 1771 I/O chassis, follow the steps listed below.



ATTENTION: Remove power from the 1771 I/O chassis backplane and field wiring arm before removing or installing an I/O module.

- Failure to remove power from the backplane or field wiring arm could cause module damage, degradation of performance, or injury.
- Failure to remove power from the backplane could cause injury or equipment damage due to possible unexpected operation.

-
1. Turn off power to the I/O chassis.
 2. Place the printed circuit board on the rear module in the plastic tracks at the top and bottom of the slot that guide the module into position.
 3. Do not force the module into its backplane connector. Apply firm, even pressure on the module to seat it properly.
 4. Snap the chassis latch over the top of the module to secure its position.
 5. Connect the field wiring arm to the module.
 6. Make wiring connections to the field wiring arm as indicated in Figure 1.

Installation Instructions

AC (12–120V) Output Module
Cat. No. 1771-OAD Series B

Connecting Wiring to the Output Module

Connections to the output module are made to the field wiring arm (cat. no. 1771-WH) shipped with the module. An optional fused field wiring arm is available (cat. no. 1771-WHF) which provides individual fusing for each circuit. Attach the field wiring arm to the pivot bar on the bottom of the I/O chassis. The field wiring arm pivots upward and connects with the module so you can install or remove the module without disconnecting the wires.

Refer to Figure 1. You must supply ac (L1) at terminals A through D on the field wiring arm. You need four ac connections to accommodate the total required surge rating on the module without overstressing any single connection on the field wiring arm. Jumper all ac (L1) connections together to prevent module damage.

Figure 1
Connection Diagram

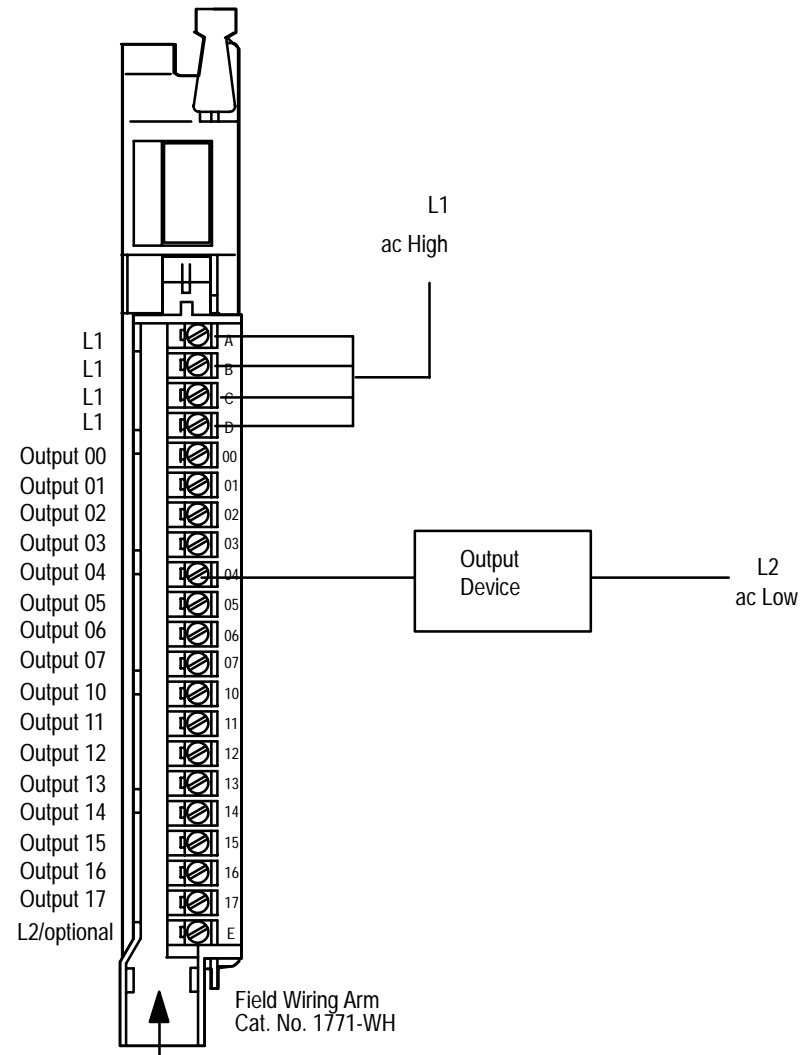

(Actual wiring runs in this direction.)

12223-1

Important: You can use an AC (120V) Output Module (cat. no. 1771-OAD) to directly drive terminals on an AC/DC (120V) Input Module (cat. no. 1771-IAD) (Figure 2).

Figure 2
Driving an Input Module with an Output Module

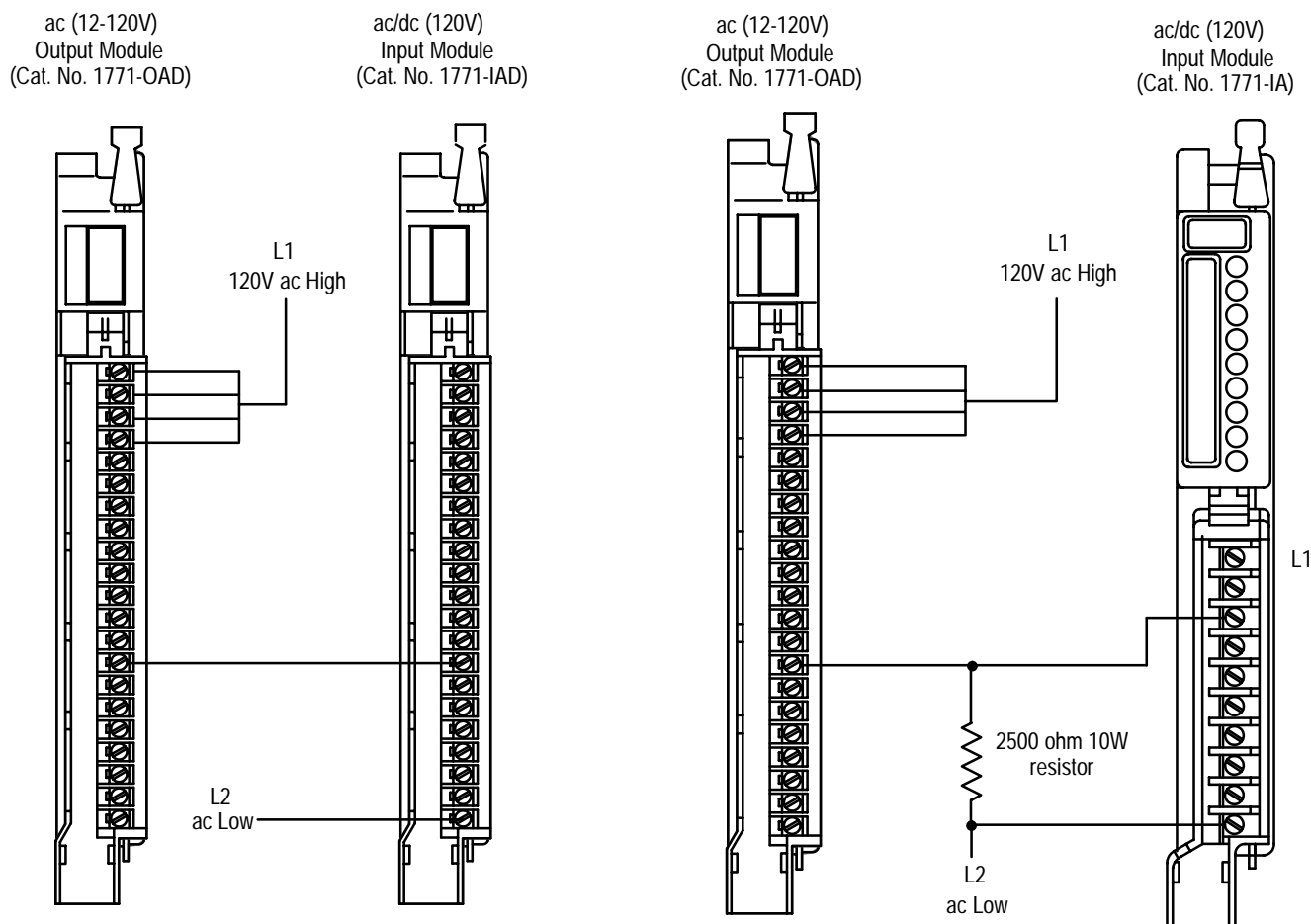

12224-I

You can also use a 1771-OAD Output module to drive an AC/DC (120V) Input Module (cat. no. 1771-IA) but you must connect one of the following between the output terminal and L2 (common) as shown in Figure 2.

- 2500 ohm, 10W resistor
- RG-1676-1 Electrocube (San Gabriel, California)

Use the same ac power source to power both modules to ensure proper phasing and prevent module damage.

Interpreting the Status Indicators

The front panel has one green module active indicator, 16 red status indicators, and one red fuse-blown indicator (Figure 3).

The green module active indicator lights when:

- the rack power supply has properly established 5V dc, and
- the processor is placed in run mode

When the module is in the CSI mode, the green module active indicator lights only when the rack power supply has properly established 5V dc.

To properly interpret the red status indicators, the module active indicator must be lit.

The status indicators are provided for system logic side indication of individual outputs. When a status indicator lights, voltage is present at the output terminal.

The fuse-blown indicator lights when the fuse has blown or been cleared.

Figure 3
Status Indicators

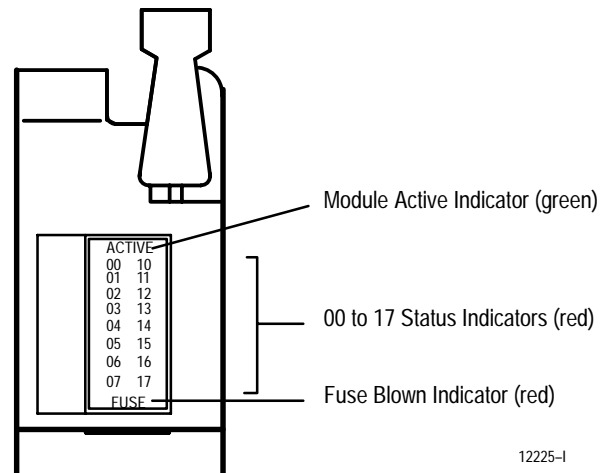

Replacing the Fuse

The module's output circuitry is protected from overload or shorts by a fuse. You can replace the fuse as outlined below.

1. Turn off all power to the I/O chassis and all output device power to the field wiring arm.



ATTENTION: Remove power from the 1771 I/O chassis backplane and wiring arm before removing or installing the module.

- Failure to remove power from the backplane or field wiring arm could cause module damage, degradation of performance, or injury.
- Failure to remove power from the backplane could cause injury or equipment damage due to possible unexpected operation.

2. Remove the module from the chassis and replace the blown fuse with a 10A, 250V rectifier fuse (1/4 x 1-1/4 inch), Littelfuse part number 322010.
3. Replace the module in the chassis and attach the field wiring arm.
4. Turn OFF all outputs to the module.
5. Turn ON power to the I/O chassis only.
6. Check that the red status indicators on the front of the module (Figure 3) are off (no outputs on).
7. Turn on output device power to the field wiring arm.
8. Start with bit 00 and turn on individual outputs one at a time. Turn off the previous output before turning on the next output.
9. If the red fuse blown indicator turns on, note which output is faulty and trace the output wiring to the faulty device.

After correcting the fault problem, return to step 1 and begin again. If you cannot locate a faulty output, return to step 8 and turn on 2 or more outputs at the same time. Total output current should not exceed 2A per output, or 8A total per module.

Troubleshooting

Use this table to help you interpret the 1771-OAD status indicators and to troubleshoot module and system faults.

Indicator Status	Description of Fault or System Status	Action to Take
Module active ON (green)	Normal Indication.	None.
Module active ON (green) and Output status ON (red)	Check voltage at output point on swing arm.	If voltage is present, take no action. If no voltage is present, check the fuse. If the fuse is OK, replace the module.
Module active ON (green) and Output status OFF	No voltage.	None.
	Voltage on terminal.	Replace the module.
Module active OFF and Output status ON (red) or OFF	1. Processor is in program mode. 2. Module not functioning properly.	1. If module is in normal mode, take no action. If module is in CSI mode replace module. 2. Check the chassis power supply and processor. If they are OK, replace the module.
Fuse blown (red)	Outputs will not turn on.	Replace the fuse. If fuse replacement does not correct the problem, replace the module.

Installation Instructions

AC (12–120V) Output Module
Cat. No. 1771-OAD Series B

Specifications

Outputs per Module	16	
Module Location	1771-A1B through -A4B or later I/O chassis, 1771-AM1, -AM2 chassis	
Output Voltage Range	10 to 138V ac @ 47 - 63Hz	
Output Current Rating	2A per output – not to exceed 8A per module	
Surge Current (maximum)	25A per output for 100ms, repeatable every 1 second 25A per module for 100ms, repeatable every 1 second	
Minimum Load Current	5mA per output	
On State Voltage Drop (max.)	1.5V at load current > 50mA 5.8V at load current < 50mA	
Off State Leakage Current (max.)	3.0mA per output @ 138V ac	
Signal Delay (max.)	Off to On On to Off	Zero crossing 8.3ms @ 60Hz, 10.0ms @ 50Hz Zero crossing 8.3ms @ 60Hz, 10.0ms @ 50Hz
Power Dissipation	13 Watts (max.), 1.5 Watts (min.)	
Thermal Dissipation	48.0 BTU/hr (max.), 5.13 BTU/hr (min.)	
Backplane Current	295mA	
Isolation Voltage	Tested at 2500V dc for 1 second per UL508 & CSA C22.2 #142	
Environmental Conditions		
Operational Temperature	0° to 60°C (32° to 140°F)	
Storage Temperature	–40° to 85°C (–40° to 185°F)	
Relative Humidity	5 to 95% (without condensation)	
Conductors	Wire Size	14 gauge stranded maximum 3/64 inch insulation maximum
	Category	1 ¹
Keying	Between 10 and 12 Between 20 and 22	
Fuse	10A, 250V rectifier fuse (1/4 x 1-1/4 inch), Littelfuse PN 322010	
Field Wiring Arm	Standard Optional	Catalog Number 1771-WH Catalog Number 1771-WHF (fused)
Wiring Arm Screw Torque	7-9 inch-pounds	
Relay Compatibility	700–HC14A1 700–HC14A1–4 700–HT12AA1 700–HF32A1 700–HTM12RA1 700–HP32A1–4 700–HB32A1 700–CL110A1 700–R110A1 100–A09 100–A30 100–A18 700–RT10N100A1 700–CL220A1 700–C110A1	

¹ You use this conductor-category information for planning conductor routing as described in the system-level installation manual.



ALLEN-BRADLEY
A ROCKWELL INTERNATIONAL COMPANY

Allen-Bradley has been helping its customers improve productivity and quality for 90 years. A-B designs, manufactures and supports a broad range of control and automation products worldwide. They include logic processors, power and motion control devices, man-machine interfaces and sensors. Allen-Bradley is a subsidiary of Rockwell International, one of the world's leading technology companies.



With major offices worldwide.

Algeria • Argentina • Australia • Austria • Bahrain • Belgium • Brazil • Bulgaria • Canada • Chile • China, PRC • Colombia • Costa Rica • Croatia • Cyprus • Czech Republic • Denmark • Ecuador • Egypt • El Salvador • Finland • France • Germany • Greece • Guatemala • Honduras • Hong Kong • Hungary • Iceland • India • Indonesia • Israel • Italy • Jamaica • Japan • Jordan • Korea • Kuwait • Lebanon • Malaysia • Mexico • New Zealand • Norway • Oman • Pakistan • Peru • Philippines • Poland • Portugal • Puerto Rico • Qatar • Romania • Russia–CIS • Saudi Arabia • Singapore • Slovakia • Slovenia • South Africa, Republic • Spain • Switzerland • Taiwan • Thailand • The Netherlands • Turkey • United Arab Emirates • United Kingdom • United States • Uruguay • Venezuela • Yugoslavia

World Headquarters, Allen-Bradley, 1201 South Second Street, Milwaukee, WI 53204 USA, Tel: (1) 414 382-2000 Fax: (1) 414 382-4444