

Selectable Relay Contact Output Module (Cat. No. 1771-OW)

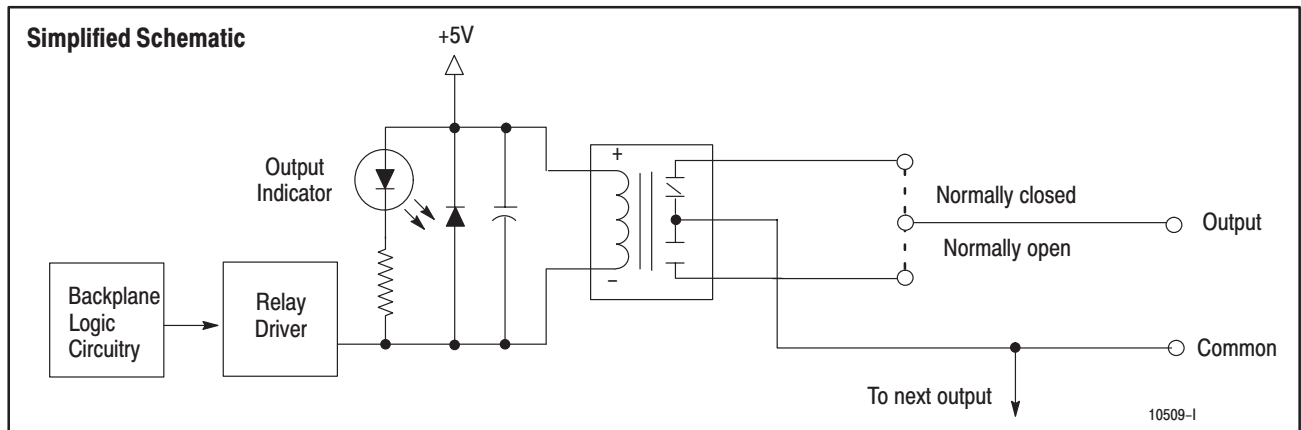

Application Notes

Load Type. 1771-OW modules do not contain surge limiting circuitry. Use these modules for switching resistive loads only (e.g., lamps, indicators, heating elements). They are not recommended for inductive or capacitive loads (e.g., motor starters, solenoids, relays).

Isolation. Outputs on the 1771-OW module are arranged in 4 groups of 2, each group with its own common. Each output is electrically isolated from module logic circuitry. The module can simultaneously switch all 8 outputs to separate loads, each conducting a maximum load of 1.0A continuously, at rated power. AC loads switched by the modules should have a power factor of 1.0.

Connection to Input Modules. You can use the 1771-OW module to drive an input of the following ac modules: 1771-IA, -IA2, -IAD, -IAN, -ID, -ID16, -IN, -IND. The 1771-OW module can drive an input of the following dc modules at nominal voltage: 1771-IB, -IBD, -IBN, -IH, -IQ, -IQ16, -IT, -IV, and -IVN. For reliable operation, a load current of at least 10mA should be maintained.

No Increase from Parallel Operation. Do not attempt to increase load current or wattage capability beyond the rating by connecting two or more outputs in parallel. The slightest variation in output relay switching time may cause one set of the contacts to switch the total load current.

Configuring Output Selection. When the output image table bit at the address corresponding to any output is energized (set to 1), the corresponding relay contact is closed or opened, respective to the jumper setting.

All outputs are individually selectable for either normally-open or normally-closed operation. They are preset for normally-open operation at the factory. See next page for relay output jumper setting.

Connection Diagram

(internal circuits on left; external circuits on right.)

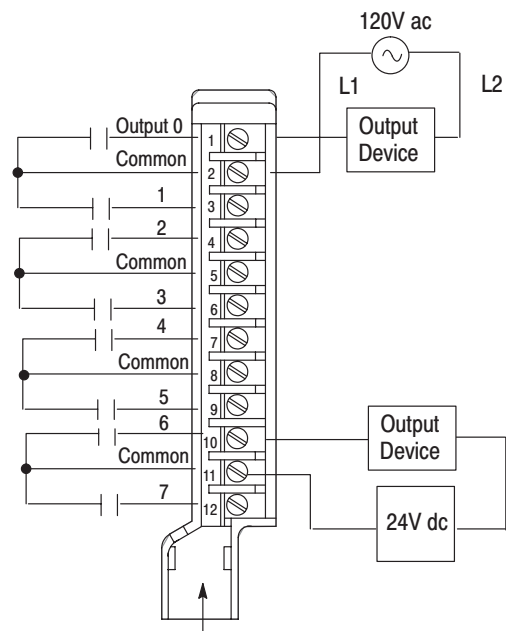

(Actual wiring runs in this direction.)

Note: Contacts are shown in N.O. configuration for simplicity. Placement of each relay's jumper sets N.O. or N.C. operation.

10510-I

Specifications (Cat. No. 1771-OW)	
Outputs per Module	8 (4 groups of 2)
Module Location	1771 I/O chassis
Voltage Rating	24 – 138V ac rms 24 – 125V dc
Current Rating ¹	1A per output (maximum)
Surge Current	1A maximum per output (at rated power) ²
Power Rating	dc: 30W per output (resistive) ac (suppressed) ² : 30W per output (resistive)
Minimum Contact Load	dc: 10mA @ 24V ac: 10mA @ 24V
Operate/Release Time	5ms(±1ms) typical
Bounce Time	1ms maximum
Switching Frequency	10Hz maximum
Power Dissipation	3.7 Watts (max.); 3.3 Watts (min.)
Thermal Dissipation	12.6 BTU/hr (max.); 11.3 BTU/hr (min.)
Backplane Current	700mA maximum
Isolation Voltage	1000V between open contacts 1500V between coil and contact
Conductors	Wire Size: 14 gauge (2mm ²) stranded maximum 3/64 inch (1.2mm) insulation maximum Category: 1 ³
Environmental Conditions	
Operating Temperature	0 to 60°C (32 to 140°F)
Storage Temperature	-40 to 85°C (-40 to 185°F)
Relative Humidity	5 to 95% (without condensation)
Keying	Between 6 and 8 Between 16 and 18
Field Wiring Arm	1771-WD
Wiring Arm Screw Torque	7-9 inch-pounds
Agency Certification (when product or packaging is marked)	<ul style="list-style-type: none"> • CSA certified • CSA Class I, Division 2, Groups A, B, C, D certified • UL listed • CE marked for all applicable directives
Installation Data	1771-2.110

¹ Spikes peaks and surges must be within the power rating. Resistive loads only. ac or dc power = 30W max.

² Surge limiting circuitry is not provided in the module. For reliable operation, the user must ensure that surges do not exceed either the voltage or current rating of the module.

³ You use this conductor category information for planning conductor routing as described in the system level installation manual.

Output	Jumper	Output	Jumper
0	K1	4	K5
1	K2	5	K6
2	K3	6	K7
3	K4	7	K8

Sample Connection Diagram for the 1771-OW Module Driving a 120V ac Input Module

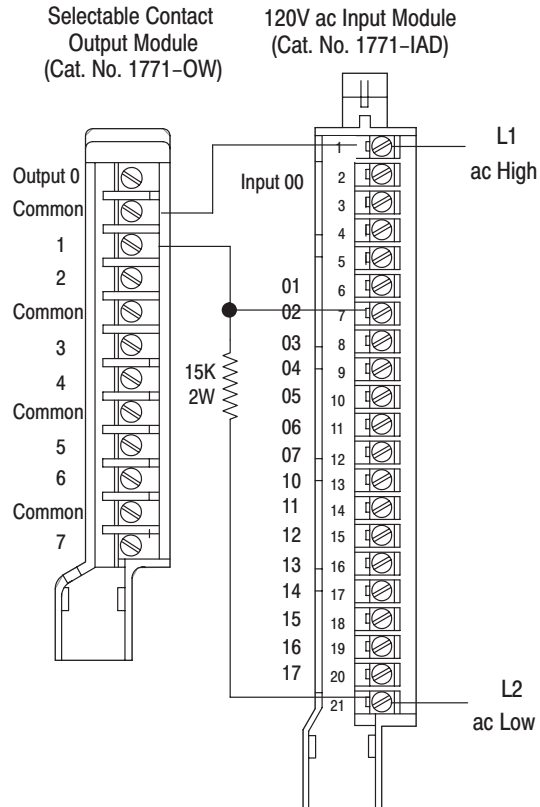

10511-1

Relay Output Jumper Setting

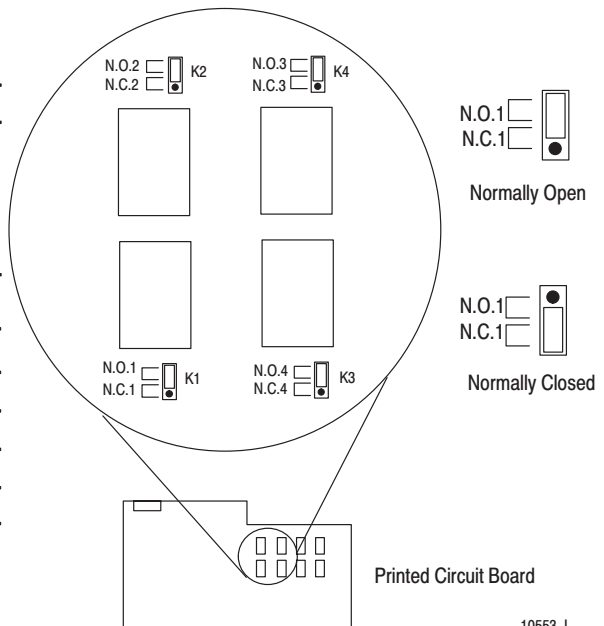

10553-1