

ABB Drives

Hardware Manual RDCU Drive Control Units



RDCU Drive Control Unit Hardware Manual

RDCU layout

Designations A...C and J1 refer to the section *Mechanical installation* below. The connectors (X...) are explained under *Technical data* further below.

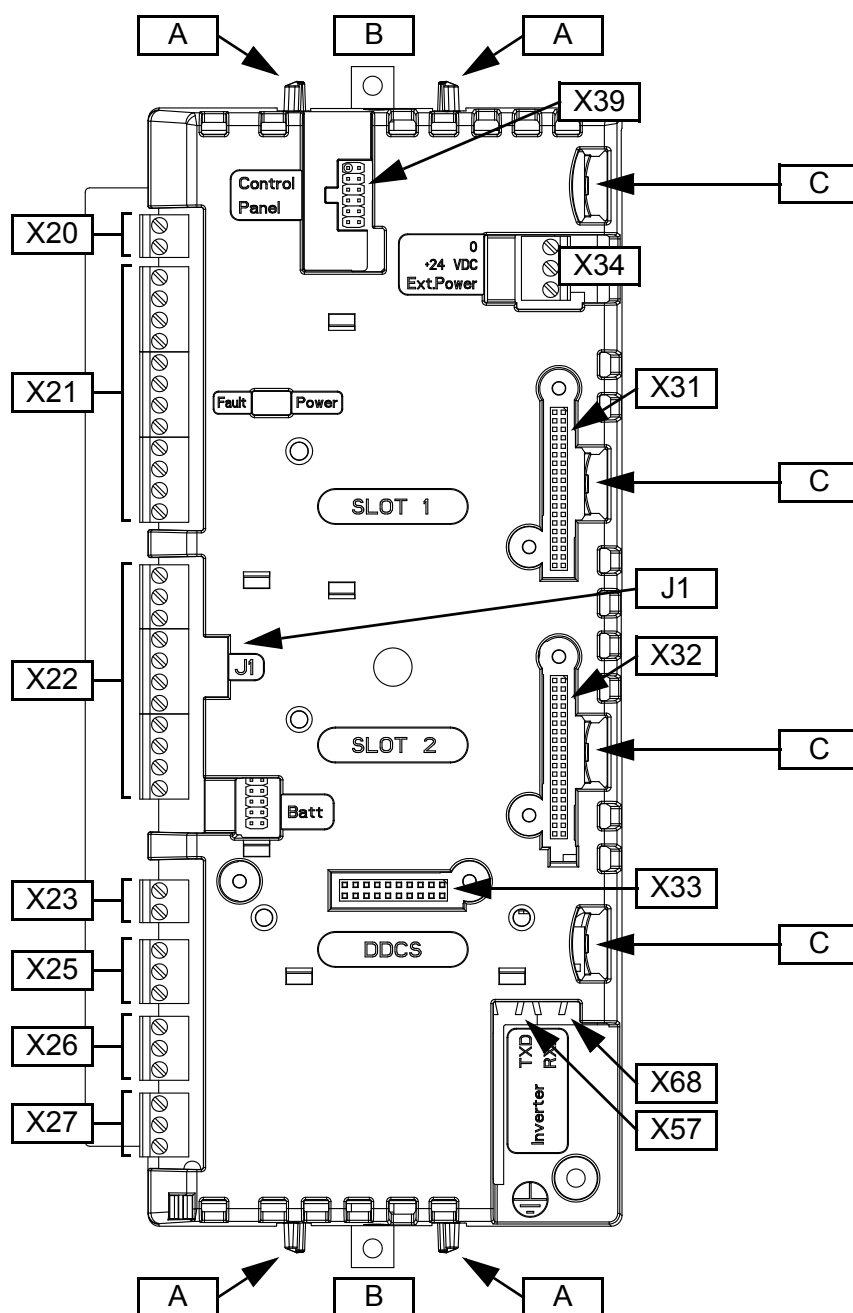

Safety instructions



Do not attempt any work on a powered drive. After switching off the mains, always allow the intermediate circuit capacitors 5 minutes to discharge before working on the frequency converter, the motor or the motor cable. It is good practice to check (with a voltage indicating instrument) that the drive is in fact discharged before beginning work.



Avoid touching the circuit board (RMIO) inside the RDCU unit in order to minimise the risk of damage caused by static electricity.

Do not use excessive force when detaching connectors or removing the cover of the unit.

Identifying different types of unit

Before installation, check that the RDCU unit has the correct application program for the converter hardware in question. There is a label attached to the cover of the RDCU unit that lists “SW TYPE”, “SW CODE” and “DEVICE TYPE”.

“SW TYPE” identifies the application program that is loaded into the RDCU unit. Some of the most common “SW TYPE” codes are **AMXRxxxx** (ACS800 System Application Program), **ASxRxxxx** (ACS800 Standard Application Program), **AHxRxxxx** (ACS800 Pump Control Application Program), and **IxxRxxxx** (IGBT Supply Unit Application Program). Check that the application program corresponds to the original order.

Check also that the “DEVICE TYPE” indicated matches that of the converter hardware.

Mechanical installation

General

The RDCU unit can be mounted on a vertical or horizontal 35 × 7.5 mm DIN rail.

The unit should be mounted so that air can freely pass through the ventilation holes in the housing. Mounting directly above heat-generating equipment should be avoided.



WARNING! Avoid installing the RDCU in the immediate vicinity of sources of electromagnetic disturbance, such as relays, contactors, brake choppers and motor cabling. The minimum recommended distance from such components is 500 mm. Installing metallic screening between the unit and the source of disturbance is highly recommended, and may reduce the required distance.

The RDCU is grounded to the mounting rail by two screws.

Fastening the unit to the mounting rail

Note: Set jumper J1 (if necessary; see the [Isolation and grounding](#) diagram) before fastening the unit.

Setting J1 can be further facilitated by removing the cover (see [Removal and replacement of cover](#) below for further instructions). The jumper can also be set using long-nosed pliers or tweezers without removing the cover.

- Align the four retaining clips (A) at the top and bottom edges of the cover with the mounting rail, and carefully press the module onto the rail until the clips catch on the edges of the rail.
- Using two screws, fasten the base plate of the RDCU by the two mounting holes (B) to the mounting rail. Make sure the contact surfaces are free from dirt or grease. This is essential for the operation of the control unit since the screws provide the grounding for the unit.

Removal of unit from mounting rail

- Remove the two screws (B) holding the base plate of the unit to the mounting rail. Carefully bend the retaining clips (A) at the upper and lower edges of the cover outwards to release the unit completely from the mounting rail.

Removal and replacement of cover

- Remove all detachable (screw-type) terminal plugs from the RDCU, and disconnect any cables connected to the unit. Remove any optional modules.

If desired, the unit can be removed from the mounting rail as described above to facilitate the following steps.

- With a screwdriver or similar tool, carefully release the four cover retaining clips (C) on the right-hand side while simultaneously pulling the right-hand edge of the cover gently away from the base plate.
- Shift the cover to the left to free its left-hand edge, then pull it to detach it completely from the base and circuit board.
- Replace the cover in reverse order to the above (left-hand edge first). If the unit is already mounted onto its mounting rail, align the retaining clips (A) so that they catch on the mounting rail.

Wiring

General

The shields of the I/O cables should be grounded to the chassis of the cubicle as close to the RDCU as possible.

Use grommets at all cable entries.

Handle fibre optic cables with care. When unplugging fibre optic cables, always grab the connector, not the cable itself. Do not touch the ends of the fibres with bare hands as the fibre is extremely sensitive to dirt.

The maximum long-term tensile load for the fibre optic cables included is 1 N; the minimum short-term bend radius is 25 mm (1").

Digital/Analogue input/output connections

See the *Firmware Manual* of the application program in question.

Installation of optional modules

Follow the instructions given in the user manual of the module.

Other connections

See also the wiring diagram below.

Powering the RDCU

The RDCU is powered through connector X34. The unit can be powered from the power supply board of the inverter (or IGBT supply) module, provided that the maximum current of 1 A is not exceeded.

The RDCU can also be powered from an external 24 V DC supply. Note also that the current consumption of the RDCU is dependent on the optional modules attached. (For current consumption of optional modules, see their respective user manuals.)

Fibre optic connection to inverter/IGBT supply module

Connect the PPCS link of the AINT (ACS 800 series modules) board of the inverter (or IGBT supply) module to fibre optic connectors V57 and V68 of the RDCU.

Note: The recommended maximum distances for the fibre optic link is 10 m (for plastic [POF] cable). In case longer distances are required, contact an ABB representative.

Connection of control panel (CDP 312R)

Connect the control panel to X39.

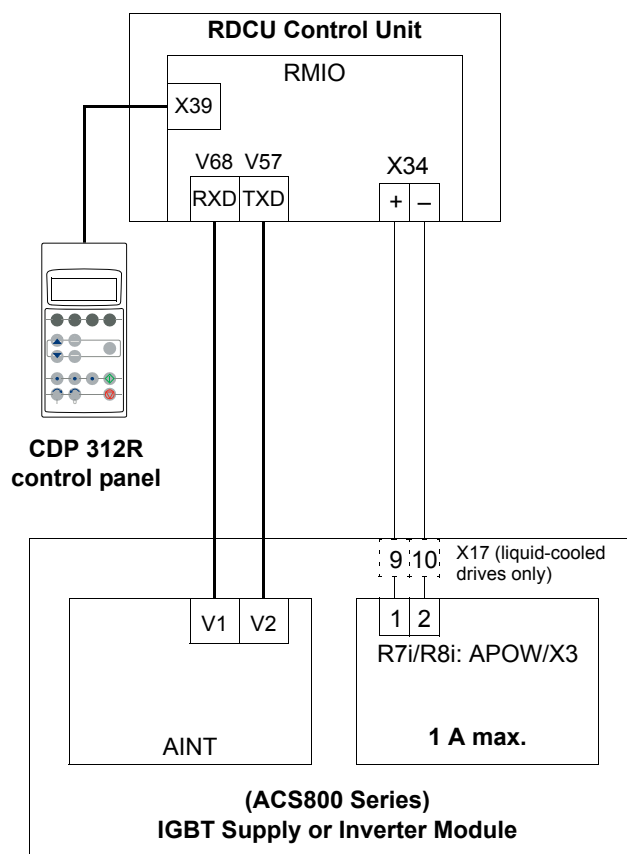

Technical data

General

Mounting: Onto 35 × 7.5 mm DIN mounting rail

Housing materials: Zinc-plated steel (base); ABS/PC (cover)

Connector types

X20 (Constant voltage output): 2-pole detachable screw terminal block*

X21 (Analogue I/O): Four 3-pole detachable screw-type terminal blocks*

X22 (Digital inputs): One 3-pole and two 4-pole detachable screw-type terminal blocks*

X23 (24 VDC output): 2-pole detachable screw-type terminal block*

X25-X27 (Relay outputs): Three 3-pole detachable screw-type terminal blocks*

X31 (Slot 1), X32 (Slot 2): 38-pin header (female), pitch 2 mm

X33 (DDCS): 20-pin header (female), pitch 2.54 mm

X34 (24 VDC power input): 3-pole detachable screw-type terminal block*

X39 (Control panel): 12-pin header (male), pitch 2.54 mm

V57, V68 (PPCS link): Fibre optic transmitter/receiver (10 MBd)

*Wire: 0.3 ... 3.3 mm² (22...12 AWG). Torque: 0.2 ... 0.4 Nm (2...4 lbf.in.).
Pitch: 5.0 mm.

Constant voltage output (X20, X21:1)

Voltage: +10 VDC, 0, -10 VDC ±0.5% (Full scale range) at 25 °C (77 °F).
Temperature coefficient: ±100 ppm/°C (±56 ppm/°F) max.

Maximum load: 10 mA

Applicable potentiometer: 1 to 10 kohm

Analogue inputs (X21)

General: Two programmable differential current inputs (0 mA / 4 mA ... 20 mA, $R_{in} = 100 \text{ ohm}$) and one programmable differential voltage input (-10 V / 0 V / 2 V ... +10 V, $R_{in} = 200 \text{ kohm}$). The analogue inputs are galvanically isolated as a group (see [Isolation and grounding](#) below)

Isolation test voltage: 500 VAC, 1 min

Max. common mode voltage between the channels: ±15 VDC

Common mode rejection ratio: ≥ 60 dB at 50 Hz

Resolution: 0.025% (12 bit) for the -10 V ... +10 V input, 0.5% (11 bit) for the 0 ... +10 V and 0...20 mA inputs

Inaccuracy: ±0.5% (Full scale range) at 25 °C. Temperature coefficient: ±100 ppm/°C max.

Analogue outputs (X21)

General: Two programmable current outputs: 0 (4) ... 20 mA, $R_L \leq 700 \text{ ohm}$

Resolution: 0.1% (10 bit)

Inaccuracy: $\pm 1\%$ (Full scale range) at 25 °C (77 °F). Temperature coefficient: $\pm 200 \text{ ppm/}^\circ\text{C}$ ($\pm 111 \text{ ppm/}^\circ\text{F}$) max.

Digital inputs (X22)

General: Six programmable digital inputs (common ground: 24 VDC, -15% ... +20%) and a start interlock input (DIIL). Group isolated, can be divided into two isolated groups (see [Isolation and grounding](#) below).

Thermistor input: 5 mA, $< 1.5 \text{ kohm} \hat{=} \text{“1”}$ (normal temperature), $> 4 \text{ kohm} \hat{=} \text{“0”}$ (high temperature), open circuit $\hat{=} \text{“0”}$ (high temperature).

Internal supply for digital inputs (+24 VDC) is short-circuit proof. An external 24 VDC supply can be used instead of the internal supply.

Isolation test voltage: 500 VAC, 1 min

Logical thresholds: $< 8 \text{ VDC} \hat{=} \text{“0”}$, $> 12 \text{ VDC} \hat{=} \text{“1”}$

Input current: DI1 to DI5: 10 mA; DI6: 5 mA

Filtering time constant: 1 ms

24 VDC power output (X23)

Voltage: 24 VDC $\pm 10\%$, short-circuit proof

Maximum output current: 250 mA (without any optional modules inserted)

Relay outputs (X25, X26, X27)

General: Three programmable relay outputs

Switching capacity: 8 A at 24 VDC or 250 VAC; 0.4 A at 120 VDC

Minimum continuous current: 5 mA rms at 24 VDC

Maximum continuous current: 2 A rms

Isolation test voltage: 4 kVAC, 1 min

Slot 1 (X31)

General: For connection of I/O extension modules (such as RAIO and RDIO), pulse encoder interface (RTAC), or fieldbus adapters (such as RPBA and RMBA)

Slot 2 (X32)

General: For connection of I/O extension modules (such as RAIO and RDIO) or pulse encoder interface (RTAC)

DDCS (X33)

General: For connection of RDCO-0x(C) DDCS Communication module

24 VDC power input (X34)

Voltage: 24 VDC $\pm 10\%$

Typical current consumption (without option modules): 250 mA

Maximum current consumption: 1200 mA (with option modules inserted)

Pin designations: 1 = not used; 2 = +24 V; 3 = 0 V

Control panel connection (X39)

General: For connection of CDP-312R control panel

PPCS link (V57, V68)

General: Optical fibre connection to inverter (or IGBT supply) module

Optical component type: 10 MBd

Protocol: ABB PPCS (Power Plate Communication System)

Jumper J1

General: See [Isolation and grounding](#) below

Pitch: 2.54 mm

LEDs

“Power”: Green; denotes +5 V power OK

“Fault”: Red

Ambient conditions

Operating temperature: +0 ... +60 °C (32...140 °F)

Storage temperature: -40 ... +70 °C (-40 ... +158 °F)

Applicable standards

Immunity: IEC 61800-3 (Limits: Industrial, Second environment); EN 50081-2 (Limits: Industrial)

Emission: EN 50081-2 (Limits: Industrial)

PELV requirements: The terminals of the RMIO board as well as on the optional modules attachable to the board fulfil the Protective Extra Low Voltage (PELV) requirements stated in EN 50178 provided that the external circuits connected to the terminals also fulfil the requirements.

Isolation and grounding

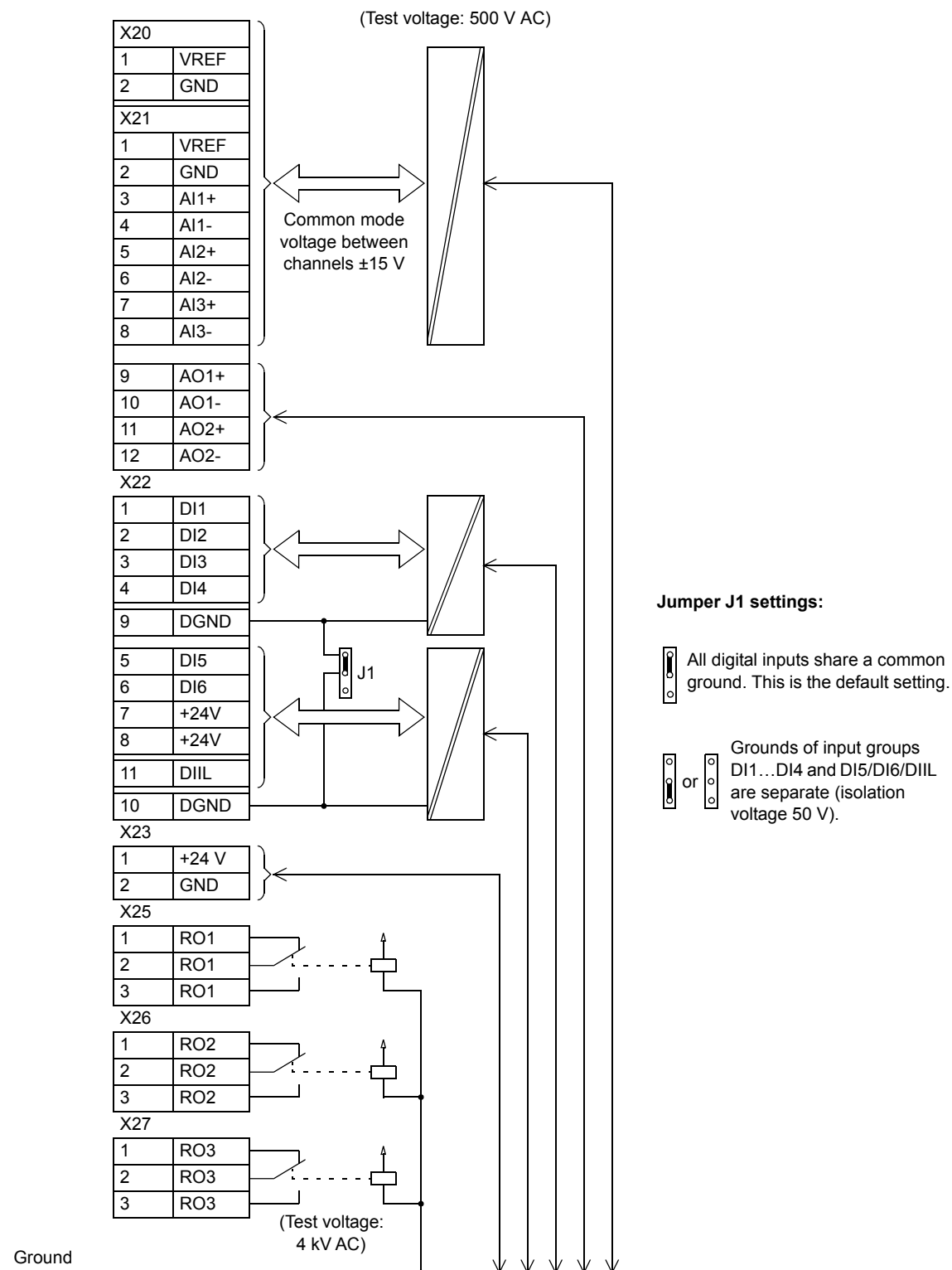

Dimensions

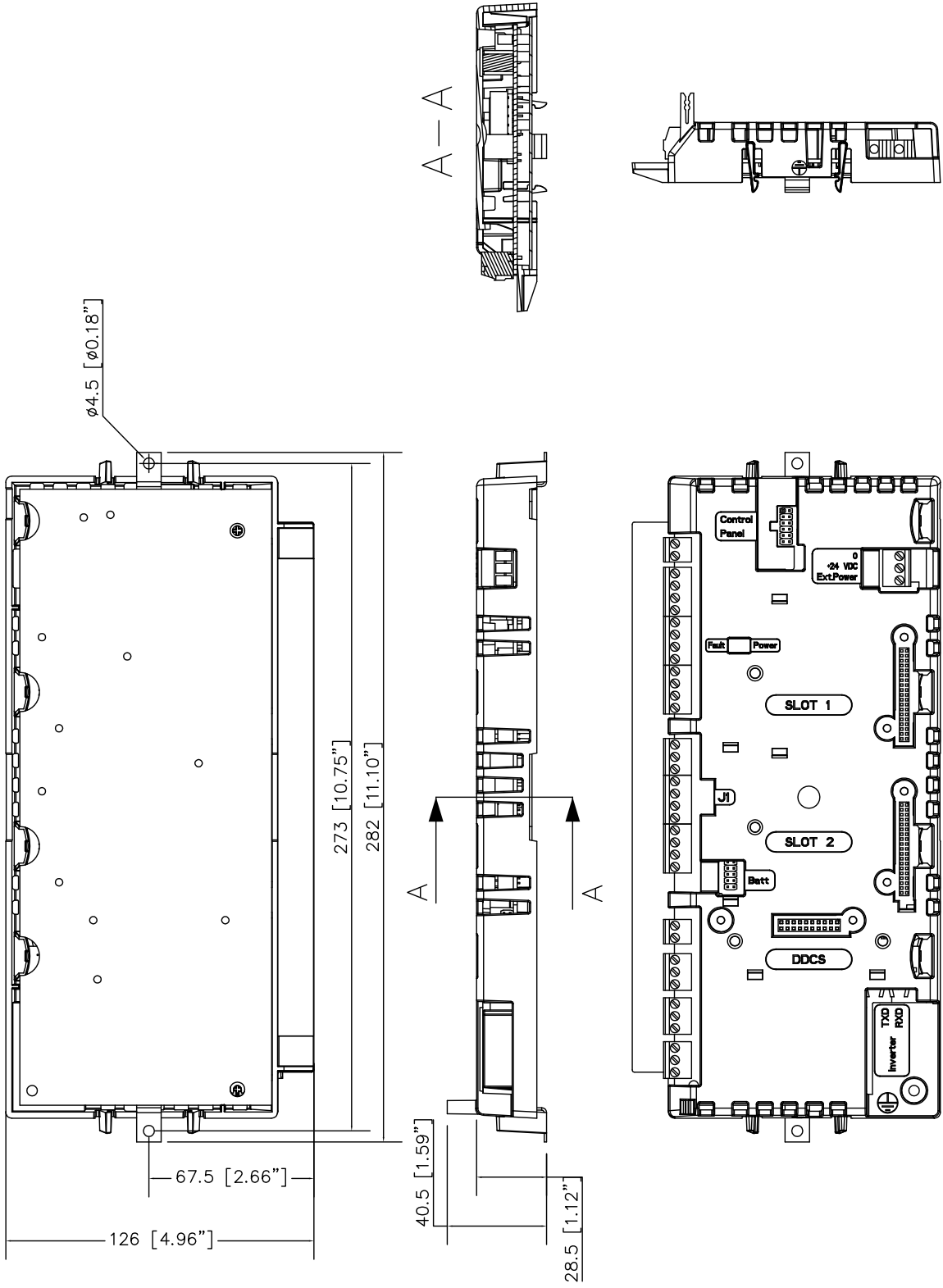



3AFE 64636324 REV C / EN
EFFECTIVE: 22.09.2008

ABB Oy

AC Drives
P.O. Box 184
FIN-00381 HELSINKI
FINLAND
Telephone: +358 10 22 11
Fax: +358 10 22 22681
Internet: <http://www.abb.com>

ABB Inc.

Drives & Power Products
16250 West Glendale Drive
New Berlin, WI 53151
USA
Telephone: 262 785-3200
800 243-4384
Fax: 262 780-5135