

Discrete Input Module

IC670MDL644

GFK-1301B
June 1997

24 VDC Positive/Negative Fast Input Module

The 24 VDC Positive/Negative Fast Input Module (IC670MDL644) provides a single group of 16 discrete inputs, which may be driven by positive or negative logic.

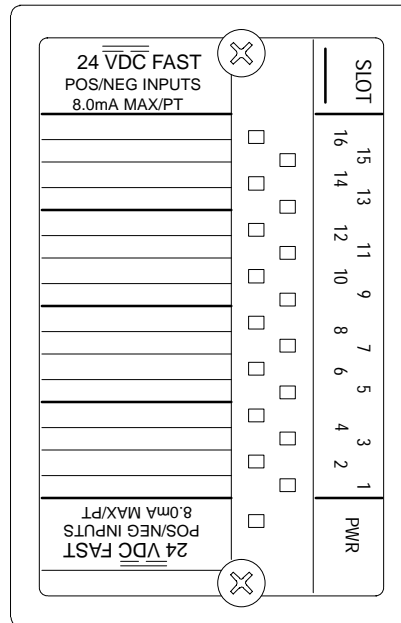

46741

Power Sources

The module receives power from the Bus Interface Unit to run its own 5-volt logic. An external 24VDC supply is needed to power the input devices.

LEDs

Individual LEDs (logic side), visible through the transparent portion of the module top, indicate the on/off status of each input. The PWR LED is on when field and backplane power are present.

Host Interface

Intelligent processing for this module is performed by the Bus Interface Unit or elsewhere in the system. This includes configuring features such as input defaults and fault reporting. The module has 16 bits (two bytes) of discrete input data. A Bus Interface Unit is required to provide this input data to the host and/or local processor.

GFK-1301B
June 1997

24 VDC Positive/Negative Fast Input Module

Module Operation

A network of resistors and capacitors establishes input thresholds and provides input filtering. Optoisolators provide isolation between the field inputs and the module's logic components. Data from all 16 inputs is placed into a data buffer. The module's circuit LEDs show the current states of the 16 inputs in this data buffer.

Parallel-to-serial converters change input data from the data buffer into the serial format needed by the Bus Interface Unit.

After checking the Board ID and verifying that the module is receiving appropriate logic power from the Bus Interface Unit (which is reflected by the state of the module's Power LED), the Bus Interface Module then reads the filtered, converted input data.

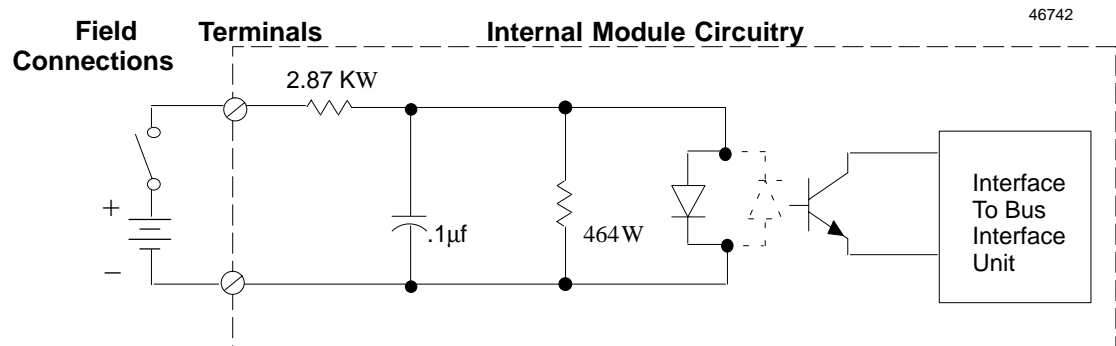

Orientation of the power supply depends upon whether inputs use positive or negative logic.

Positive or Negative Inputs

Inputs for this module can be either positive or negative inputs (all 16 inputs must be the same type). Both types of signal produce a logic 1 (true) when the switch is closed. Selection of positive or negative operation is made by the manner in which the external power supply is connected to the inputs and to the I/O Terminal Block.

Positive inputs receive current from input devices and supply current to the common or negative power bus. Input devices are connected between the positive power bus and the input terminals.

Negative inputs provide current to input devices and accept current from the common or positive power bus. Input devices are connected between the negative power bus and the input terminal.

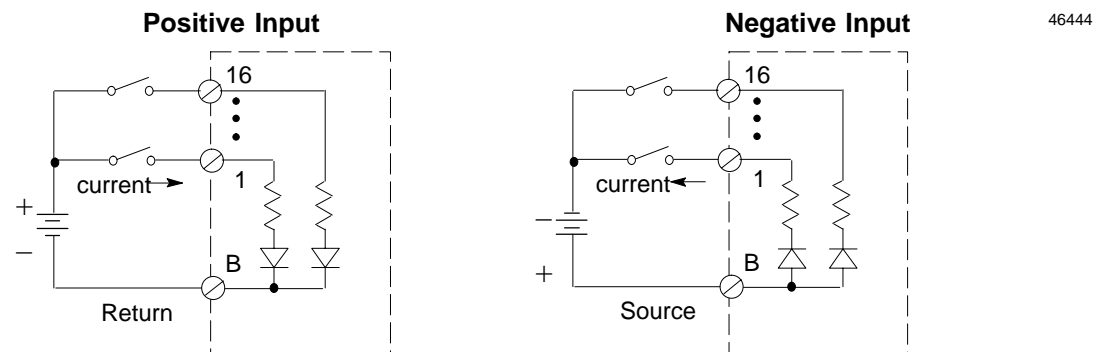

24 VDC Positive/Negative Fast Input ModuleGFK-1301B
June 1997**Module Specifications**

Module Characteristics	
Rated Voltage	24VDC
Input Voltage Range	0-30 VDC
User Input Current	8.0 mA per point @ 24 VDC
Isolation: User input to logic, user input to frame ground Point to point	250 VAC continuous, 1500 VAC for 1 minute No isolation between individual points in a group.
Indicators	1 LED per point shows individual point status PWR LED indicates field and backplane power are present
Current drawn from Bus Interface Unit Power Supply	80mA
Input Characteristics	
Input Impedance	3K typical
On state voltage	Positive logic: +15V to +30V Negative logic: -15V to -30V
Off state voltage	Positive logic: 0 to +5V Negative logic: 0 to -5V
On state Current	3.0mA to 8mA
Off state Current	0mA to 1.5mA
On response time	25 μ s typical, 60 μ s maximum
Off response time	100 μ s typical, 150 μ s maximum

Keying Locations

Optional keying locations for the 24 VDC Positive/Negative Fast Input Module are shown below.

Keying Locations									
A	B	C	D	E	F	G	H	J	K
✓		✓				✓	✓		

24 VDC Positive/Negative Fast Input Module

Field Wiring

The following illustration shows terminal assignments for the 24 VDC Positive/NegativeFast Input Module.

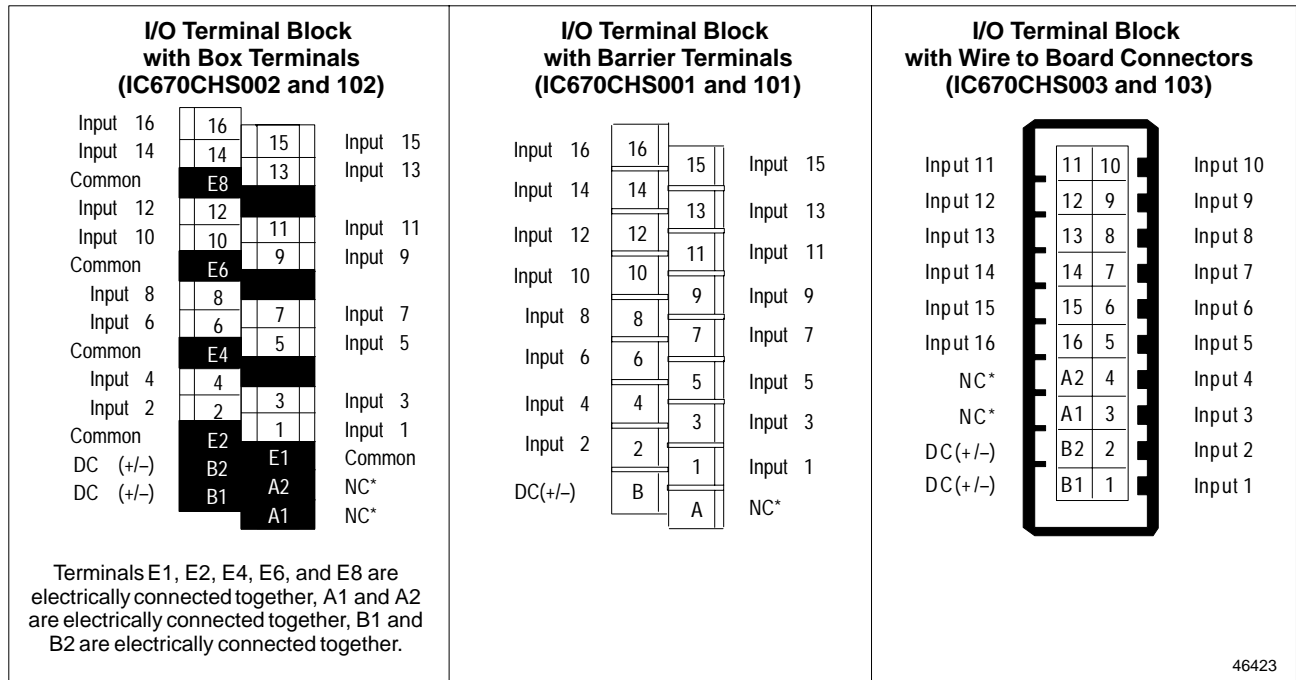

Connection to the A terminals is optional. They can be used as shown on the next page.

The Terminal Block with box terminals has 25 terminals for each module, each of which accommodates one AWG #14 (avg 2.1mm² cross section) to AWG #22 (avg 0.36mm² cross section) wire, or two wires up to AWG #18 (avg. 0.86mm² cross section). When an external jumper is used, the wire capacity is reduced from AWG #14 (2.10mm²) to AWG #16 (1.32mm²).

The I/O Terminal Block with barrier terminals has 18 terminals per module. Each terminal can accommodate one or two wires up to AWG #14 (avg 2.1mm² cross section).

The I/O Terminal Block with Connectors has one 20-pin male connector per module. The mating connector is Amp part number 178289-8. Any tin-plated contact in the AMP D-3000 series can be used with the connector (Amp part number 1-175217-5 for high contact force receptacle for 20-24 gauge (0.20-0.56mm²) wires), 1-175218-5 for high contact force receptacle for 16-20 gauge (0.56-1.42mm²).

24 VDC Positive/Negative Fast Input Module

GFK-1301B
June 1997

Wiring Examples with Auxiliary Terminal Blocks

If the module is installed on an I/O Terminal Block with Box Terminals or an I/O Terminal Block with Barrier Terminals, an Auxiliary Terminal Block may be required to provide additional wiring terminals. For the I/O Terminal Block with Wire to Board Connectors, external connection points are usually preferred, although an Auxiliary Terminal Block can be used..

Auxiliary Terminal Blocks have all terminals connected together internally. The Auxiliary Terminal Block with box terminals has 13 terminals, each of which accommodates one AWG # 14 (avg 2.1mm² cross section) to AWG #22 (avg 0.36mm² cross section) wire, or two wires up to AWG #18 (avg. 0.86mm² cross section). The Auxiliary Terminal Block with barrier terminals has nine terminals, each of which can accommodate one or two wires up to AWG #14 (avg 2.1mm² cross section).

The following illustration shows how an Auxiliary Terminal Block with Box Terminals can be used for power connections to an I/O Terminal Block with Box Terminals.

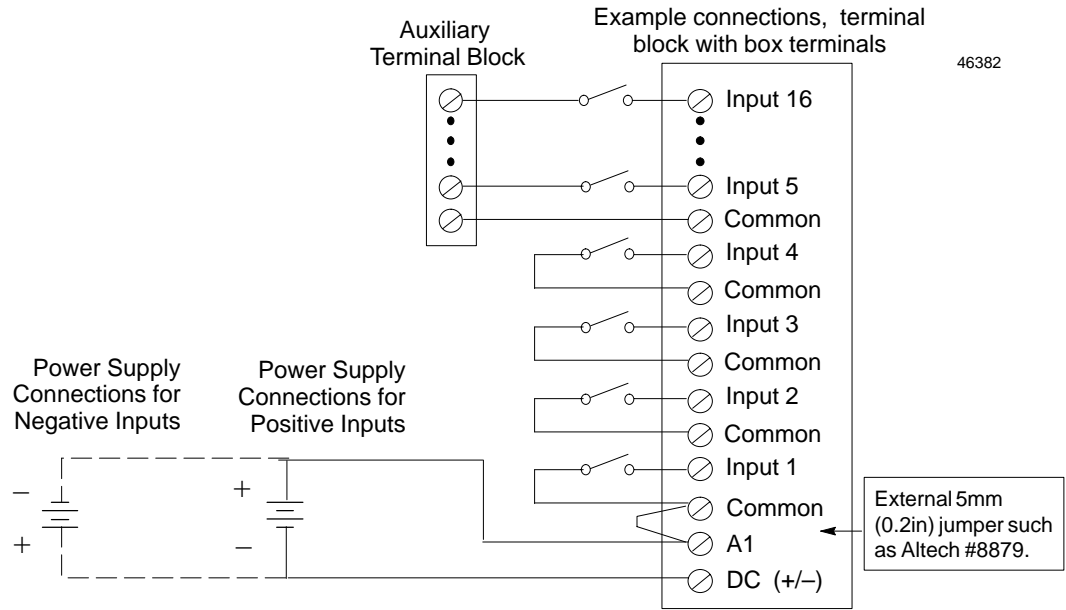

For an I/O Terminal Block with Barrier Terminals, an Auxiliary Terminal Block with Barrier Terminals might be connected as shown in the following example.

