

DC 32-Circuit Source/Sink I/O Blocks

June 2002

GFK-0044F

Description

A DC 32-Circuit Source/Sink I/O Block is an intelligent, configurable module that interfaces the controller to devices that provide or accept a binary signal. The blocks are compatible with a wide range of input devices, including both 2-wire and 3-wire electronic proximity switches. Outputs may be low-power control and indicating devices such as relays, contactors, and lamps. Two models are available:

- **12/24 VDC 32- Circuit Source block** (IC66*BBD024), which provides current to field output devices.
- **5/12/24 VDC 32-Circuit Sink block** (IC66*BBD025), which receives current from field output devices.

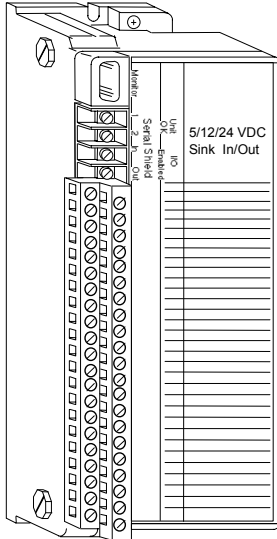

Features

- Source and Sink versions each operate at nominal 12 to 24 volts DC
- Sink version is also +5 volt TTL-compatible
- Thirty-two configurable I/O circuits, inputs and outputs can be mixed on block
- Resettable self-protecting circuits
- Software configurable
- Advanced diagnostics

These blocks have 32 identical discrete I/O circuits, each easily configured to be an input, an output, or an output with feedback. This flexibility provides maximum design and application efficiency.

Each circuit contains built-in protection when used as an output, protecting the driver while allowing short-time surges. It also protects against shorted loads caused by wiring errors.

Block LEDs verify proper block operation and CPU communications. Individual circuit LEDs on the logic side indicate voltage present on inputs and outputs.:

Using this Datasheet

This datasheet summarizes information about block installation, configuration, and diagnostics.

Your primary reference should be the Discrete and Analog Blocks User's Manual. It includes detailed instructions for block installation and configuration.

For additional information about systems and communications, including bus specifications, refer to the *I/O System and Communications Manual*.

Specifications

Catalog Numbers			
32 Circuit 12/24 VDC Source I/O Block	IC66*BBD024		
Terminal Assembly	IC66*TBD024		
Electronics Assembly	IC66*EBD024		
32 Circuit 5/12/24 VDC TTL Sink I/O Block	IC66*BBD025		
Terminal Assembly	IC66*TBD025		
Electronics Assembly	IC66*EBD025		
Block Specifications			
Size (height x width x depth)	8.83" (22.43 cm) x 3.58" (9.1 cm) x 4.7" (11.94 cm)		
Weight	4 lbs. (1.8 kg)		
LEDs (I/O Block)	Unit OK, I/O Enabled		
LEDs (each circuit)	Individual logic side indicators		
Block to block Isolation	850V		
Heat Dissipation	11W minimum with 8 inputs 18W maximum with 32 outputs at .5 Amp		
Operating voltage (one source)	10 to 30 VDC (12/24 V supply) 4.9 to 5.3 VDC (5 V supply) (sink only) absolute instantaneous limit		
Ripple (maximum)	10% (12/24 volts) , 1% (5 volts)		
Required DC power	150 mA typical/300 mA maximum		
Power supply dropout time	4 ms at 12 volts, 20 ms at 24 volts		
Input Specifications			
Input voltage relative to DC-	Source Blocks	Sink Blocks	
Input ON	5 VDC supply	not applicable	0-0.8 VDC
	12 VDC supply	8-12 VDC	0-4 VDC
	24 VDC supply	18-24 VDC	0-6 VDC
Input OFF	5 VDC supply	not applicable	2-5 VDC
	12 VDC supply	0-6 VDC	6-12 VDC
	24 VDC supply	0-12 VDC	12-24 VDC
Input impedance (typical)	3.3K Ohms		
Input processing time (typical)	1.4 ms (plus selectable filter delay)		
Selectable input filter times	1, 2, 3, 4, 5, 10, 20, 30, 40, 50, 60, 70, 80, 90, or 100ms		
Output Specifications			
Maximum output current (steady state)	0.5 Amps per circuit		
Maximum inrush current	4 Amps up to 10ms (once every .5 sec. maximum)		
Block output current (total)	16 Amps		
Output OFF leakage current	10µA, maximum		
Output turn-on delay	0.5 ms, maximum		
Output voltage drop	2.0 volts maximum at 4 Amps inrush		
Output Diagnostics	Switch Fault		
Environmental Specifications			
Operating Temperature	-0° to +60°C (32° to +140°F)		
Storage Temperature	-40 °C (-40° to +212°F)		
Humidity	5% to 95% (non-condensing)		
Vibration	5-10 Hz 0.2" (5.08mm) displacement, 10-200 Hz at 1G		

Refer to GFK-0867 for product standards and general specifications.

Compatibility

These blocks are compatible with Hand-held Monitor model IC66*HHM501 only. Note that Hand-held Monitor IC66*HHM501 version A (an older version) will only display all references for a 32-circuit block if it is made the "Active Block".

For an IC600 series PLC, the Bus Controller may be model IC66*CBB902 or CBB 903, any version; or model IC66*CBB900 or CBB901 version 1.3 or later.

If used to control operation of a Bus Switching Module, BSM IC66*BSM021 is required. The block must operate at 18 volts or above.

DC 32-Circuit Source/Sink I/O Blocks

June 2002

GFK-0044F

Installation Instructions

Carefully inspect all shipping containers for damage. If any equipment is damaged, notify the delivery service immediately. Save the damaged shipping container for inspection by the delivery service. After unpacking the equipment, record all serial numbers. Save the shipping containers and packing material in case it is necessary to transport or ship any part of the system.

Block Mounting

Genius I/O blocks are considered "open equipment" and therefore must be installed within a protective enclosure. They should be located in an area that is clean and free of airborne contaminants. There should be adequate cooling airflow.

The block can be mounted right side up, or upside down. Leave at least 2 inches of space between blocks. Mount the block by drilling two screw or bolt holes for 8-32 hardware. Position the block so that the notches in the upper and lower flanges line up with the mounting holes. Mount the block using 8-32 screws. Use star washers to provide ground integrity.

Removing an Electronics Assembly

The block's Electronics Assembly can be replaced with a compatible model without removing field wiring or reconfiguring the block.

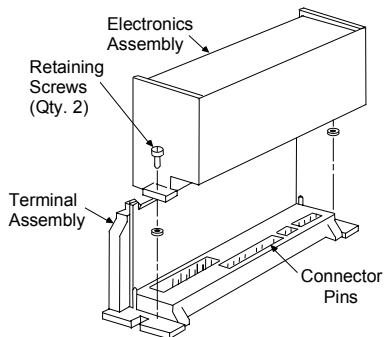

1. Unscrew the retaining screws at the top and bottom of the block.
2. Using a Block Puller (IC660BLM507), engage the tabs in the first vent slots. Move the tool to the center of the block and squeeze the handle.
3. Pull the Electronics Assembly upward.

WARNING

If power is applied to the field terminals, power is also exposed on the connector pins at the base of the Terminal Assembly, and electrical shock hazard exists. Do not touch the connector pins! Death or injury may result.

Inserting an Electronics Assembly

1. Align the Electronics Assembly in the guides and push down firmly.

CAUTION

Do not exert excessive force; it may damage the block.

If unusual resistance is met, remove the Electronics Assembly. If power is applied to the block, DO NOT TOUCH THE CONNECTOR PINS! Inspect the Terminal Assembly, connector receptacle, and connector edge board (on the Electronics Assembly). Be sure the keying matches. Remove any obstacles and reinsert the Electronics Assembly. Pay close attention to the alignment of the guide pins.

2. Secure the Electronics Assembly with the screws on the top and bottom of the Terminal Assembly.

Grounding

The block's mounting screws must not be used as the only means of grounding the block. Connect the green ground screw on the block to a reliable ground system using a short wire lead, minimum size AWG #12 (avg 3.3mm² in cross-section).

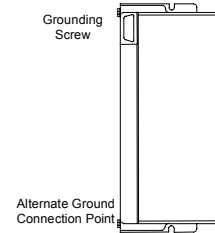

WARNING

If mounting screws do not make good ground connection and the ground screw is not connected to a reliable ground, the block is not grounded. Electrical shock hazard exists. Death or personal injury may result.

Serial Bus Wiring

Do not overtorque the terminal screws. Recommended torque for all terminals is 6 in/lb (.678 N/M).

Terminals 1 to 4 are for the serial bus. They accept one AWG #12 wire (avg. 3.3mm² in cross-section) or two AWG #14 wires (each avg 2.1mm²). The minimum recommended wire size is AWG #22 (avg .36mm²).

Terminals 1 to 4 can also accommodate spade or ring lugs up to 0.27 inch (6.85 mm) in width with a minimum opening for a #6 screw, and up to 0.20 inch (5.1 mm) depth from the screw center to the back barrier. Be sure unshielded wire ends are not longer than 2 inches (5cm).

Using one of the cable types recommended in the System and Communications User's Manual, connect the serial bus to terminals 1-4. (If a Bus Switching Module will be connected directly to the block, see below instead).

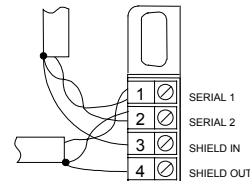

If the block is at either end of the bus, connect a terminating resistor of the appropriate type (see the System and Communications User's Manual for details) across its Serial 1 and Serial 2 terminals.

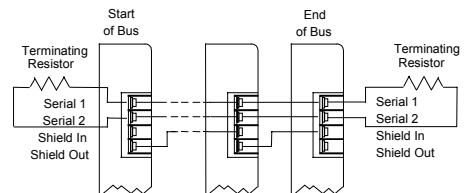

Wiring for a Bus Switching Module

If the block will be a BSM Controller, attach the Bus Switching Module to the block's serial bus terminals. Attach the serial bus cables to the BSM as described in the Bus Switching Module datasheet. Wire the BSM like a load to circuit 1. Connect either BSM pigtail wire to terminal 6. For a DC Sink block, connect the other BSM wire to DC+. For a DC Source block, connect the other BSM wire to DC-.

DC 32-Circuit Source/Sink I/O Blocks

June 2002

GFK-0044F

Field Wiring

Terminals 5 to 46 are for field devices. Each terminal accepts one AWG #14 wire (avg 2.1mm² cross section), two AWG #14 (2.1mm² cross section) solid wires, or two AWG #16 (each avg 1.3mm² in cross section) stranded wires.

Any circuit can be an input or output. Connect one terminal of a field device to DC power and the other to the block (terminals 10-41). All I/O devices must return to the same power circuit.

Depending on layout and current loads, positive and negative connections can be bussed and made by single wires to the block or power source.

Connections for a DC Source Block

For a Source block, connect outputs to the negative side of the power supply and inputs to the positive side.

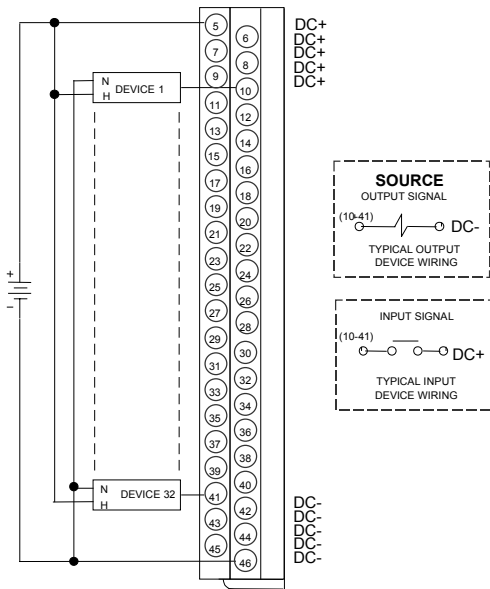

DC Source Block, Power Disconnects

It is important to wire block power disconnects so that block power and input power will be removed at the same time. Locate the power disconnect as shown below.

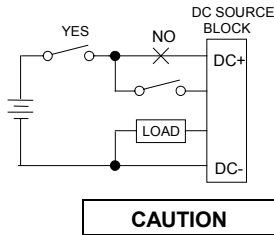

If circuit power is not removed at the same time as block power, the block may power up when multiple inputs are activated, even though one leg of power has been removed from the block.

If you want to disable the block without removing power from input devices, use a Block Puller to unplug the Electronics Assembly. Do not disconnect H or N to remove power.

Connections for a DC Sink Block

For a Sink block, connect outputs to the positive side of the power supply and inputs to the negative side. Connect a DC source to the DC+ terminals (6-9) and the return to the DC- terminals (42-46).

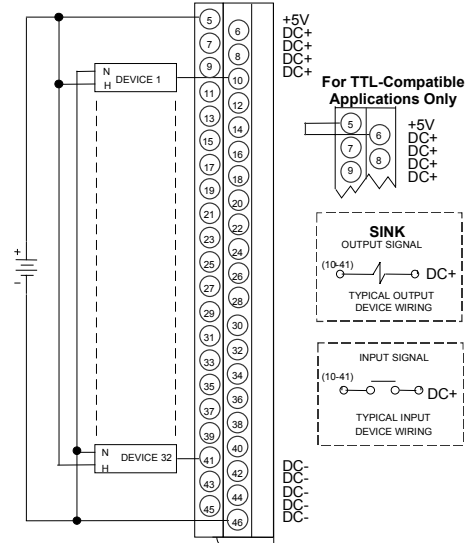

For correct 5 volt operation, power to the block, measured at the power supply input terminals, must be within the range 4.9VDC to 5.3VDC.

CAUTION

Do not apply more than 5.25 volts to the +5V terminal. Damage to the block may result.

For 5 volt Sink applications only, jumper the +5V terminal to any DC+ terminal.

CAUTION

For 12 or 24 volt sink applications do not jumper the +5V terminal to DC+. It will damage the block. Leave the +5V terminal open.

DC Sink Block, Power Disconnects

Since block power is the same as circuit power, it is important to wire block power disconnects so that block power and input power will be removed at the same time. Locate the power disconnect as shown below.

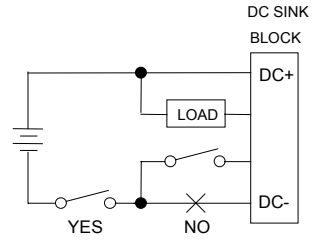

If circuit power is not removed at the same time as block power, the block may power up when multiple inputs are activated, even though one leg of power has been removed from the block.

If you want to disable the block without removing power from input devices, use a Block Puller to unplug the Electronics Assembly. Do not disconnect H or N to remove power.

DC 32-Circuit Source/Sink I/O Blocks

June 2002

GFK-0044F

Block Operation

These blocks provide 32 identical circuits, each configurable as an input or output. For both types of blocks, output circuits can be directly connected to input circuits without the use of other components or inversion of logic states.

Source Block

A DC source block has all output devices connected to the negative (-) side of the power supply. Inputs control the positive (+) side. For outputs, an ON condition is logic 1 and an OFF condition is a logic 0.

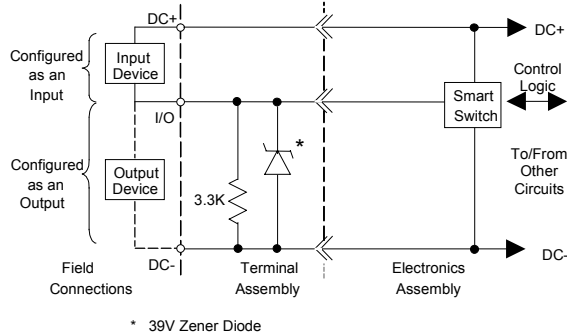

Sink Block

A DC sink block has all output devices externally connected to the positive (+) side of the power supply. Inputs control the negative (-) side. For outputs, an ON condition is logic 0 and an OFF condition is a logic 1.

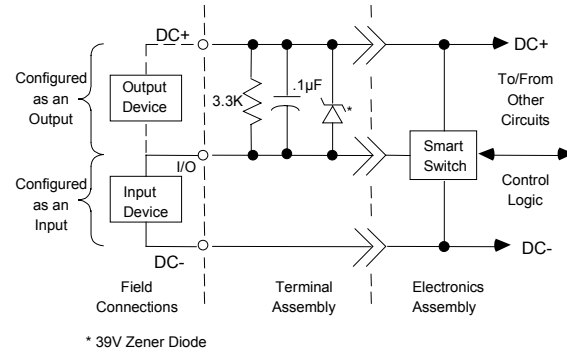

LEDs

The block's Unit OK and I/O Enabled LEDs show its operating status:

Unit OK	I/O Enabled	Meaning
ON	ON	Block functioning, CPU communicating
ON	OFF	Block functioning, No CPU communications for 3 bus scans
ON	Blinking	Block functioning, Circuit forced
Blinking	ON	Circuit fault, CPU communicating
Blinking	OFF	Circuit fault, No CPU communications for 3 bus scans
Alternate Blinking		Circuit fault, Circuit forced
Synchronous Blinking		No CPU communications - block number conflict
OFF	OFF	No block power, or block faulty

Each circuit has its own LED. If the circuit is configured as an input, the LED indicates the presence of threshold voltage at the input terminal. If the circuit is configured as an output, the LED indicates the actual state of the load.

Diagnostics

The block monitors outputs for overload conditions, and checks the actual state of the switch against the commanded state. In case of **overload** or wrong switch state, the block reports: FAILED SWITCH.

Short Circuit/Overcurrent Protection: diagnostics protect individual output circuits against excess current. For Source blocks, the load usually gets short-circuited to the DC- side of the supply. For Sink blocks, the load usually gets short-circuited to the DC+ side.

If the output is commanded to go on and current exceeds 5 Amps for 1 ms, the circuit is automatically turned off and the FAILED SWITCH message issued. The circuit must be reset by cycling power to the block, or by sending a CLEAR FAULTS command from the Hand-held Monitor or the Bus Controller.

Surge Currents: Both Source and Sink blocks handle steady-state loads of 0.5 Amps during normal operation. Surge current protection determines conditions for safely switching loads between 0.5 Amps and 4 Amps. The following chart shows allowable surge transients.

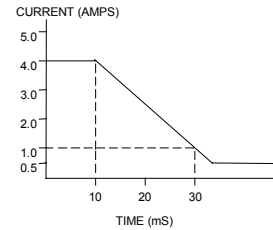

CAUTION

Failure to operate a circuit within these limits may result in thermal overload and damage to the block.

Configuration

First, the block must be configured with a Hand-held Monitor to:

- Enter its Device Number (serial bus address).
- Enter its Reference Number (required only for IC600 and IC550 series PLCs only).

In addition, unless all circuits on the block will be inputs, the Block I/O Type must be set to either Outputs or Combination on the Program Block ID screen.

Note: If a block is configured offline, it must be properly grounded and have a 75 Ohm resistor installed across its Serial 1 and Serial 2 terminals.

The rest of the features can be configured either using a Hand-held Monitor, or by sending a Write Configuration datagram to the block from the host.

Feature	Circuit or Block	Factory Setting	Selections
Baud Rate	B	153.6 std	153.6 std, 153.6 ext, 76.8, 38.4
Block I/O Type	B	input	input, output, combination
Pulse Test	B	enabled	enabled, disabled
Input Filter Time	B	20ms	1-100ms
Circuit I/O Type	C	input	input, output
Report Faults	C	yes	yes, no
Hold Last State	C	no	yes, no
Output Default State	C	off	on, off
BSM Present	B	no	yes, no
BSM Controller	B	no	yes, no
Output Timeout	B	2.5 sec.	2.5, 10 seconds
Redundancy Mode	B	none	none, standby, duplex, GMR
Duplex Def. State	B	off	on, off
Config. Protect	B	disabled	enabled, disabled