



**Supercomputing levels of performance in a scalable, single-board computer**

The MVME5100 Series is the flagship of the Motorola PowerPlus II VME Architecture line, enabling supercomputing levels of performance in a single VMEbus slot. Based on an integrated PCI bridge-memory controller ASIC designed by Motorola Computer Group, PowerPlus II takes memory performance to new levels with 582MB/s memory read bandwidth and 640MB/s burst write bandwidth. Plus, PowerPlus II Architecture supports full PCI throughput of 264MB/s without starving the processor from its memory.

The extended temperature versions of the MVME5100 Series offer hardware and software compatible products to enhance the existing MVME5100 product. The new versions operate at extended temperature ranges of -20° to 71° C vs. 0° to 55° C for the already existing commercial versions. The temperature range is advantageous to OEMs that require extended operating temperatures for their equipment.

The MVME5100 is designed to meet the needs of OEMs servicing the defense and aerospace, industrial automation and medical market segments.

- MPC7410, MPC750 or MPC755 class microprocessor with 32KB/32KB L1 cache
- Up to 2MB of secondary backside cache
- 100 MHz front-side bus
- Up to 512MB of on-board ECC SDRAM—expandable up to 1GB with optional RAM500 memory expansion modules
- 17MB Flash memory
- Dual IEEE P1386.1 compatible 32/64-bit PMC expansion slots
- 64-bit PCI expansion mezzanine connector allowing up to four more PMCs
- Dual 16550 compatible async serial ports
- Dual 10BaseT/100BaseTX Ethernet
- 32KB NVRAM and time-of-day clock with replaceable battery backup
- Four 32-bit timers and one watchdog timer
- On-board debug monitor
- Single VME slot even when fully configured with two PMC modules and both add-on memory mezzanines

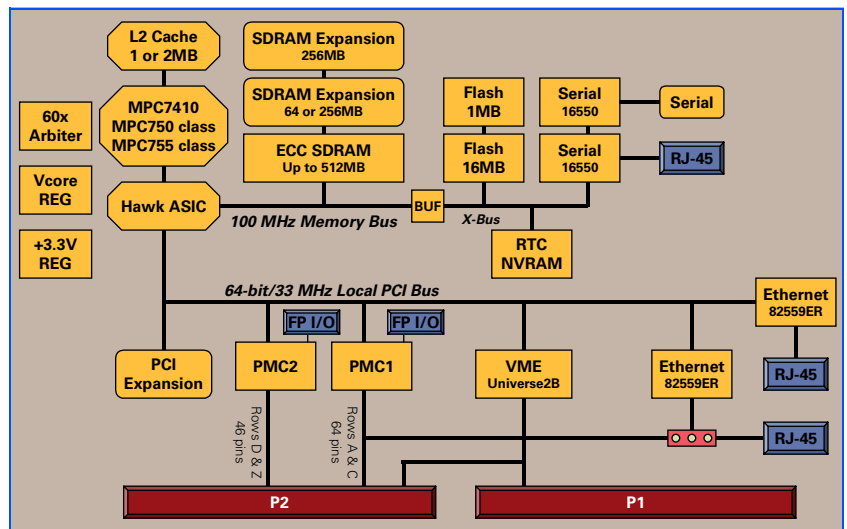

### I/O Compatibility

Historically, Motorola has offered two tracks in its PowerPC Architecture VME portfolio. The first track (which includes the MVME2600/2700) provides typical single-board computer I/O features including Ethernet, SCSI, multiple serial ports, a parallel port and a single PMC slot. The on-board I/O is routed to P2 and made available to the user via Motorola MVME761 or MVME712M transition boards. The second track (which includes the MVME2300/2400) offers limited on-board I/O (Ethernet and a single serial port both via the front panel) but provides dual PMC slots enabling maximum user I/O customization.

The MVME5100 merges the best features of both tracks enabling the OEM to support varying I/O requirements with the same base platform, simplifying part number maintenance, technical expertise requirements and sparing.

### P2 I/O Modes

The MVME5100 supports two, jumper-configurable P2 I/O modes, PMC mode and IPMC mode.

PMC mode is backward compatible with the MVME2300/MVME2400. In PMC mode, 64 pins from PMC slot 1 and 46 pins from PMC slot 2 are available on P2 for PMC rear I/O.

In IPMC mode, the MVME5100 supports legacy MVME761 or MVME712M I/O modules (with limited PMC I/O) when an IPMC761 or IPMC712 PMC card is populated in PMC slot 1. In this configuration, PMC slot 2 contains some signals that are reserved for extended SCSI.

### IPMC Modules

The IPMC761 and IPMC712 are optional add-on PMC modules that provide backward compatibility with previous-generation Motorola products (such as MVME2600 and MVME2700) using the MVME761 or MVME712M transition board. IPMC modules provide rear I/O support for the following:

- One single-ended Ultra Wide SCSI port
- One parallel port
- Four serial ports (2 or 3 async and 1 or 2 sync/async, depending on module)

With this PMC card configuration, the memory mezzanine, one PMC slot and the PMCspan are still available, providing support for OEM product customization.

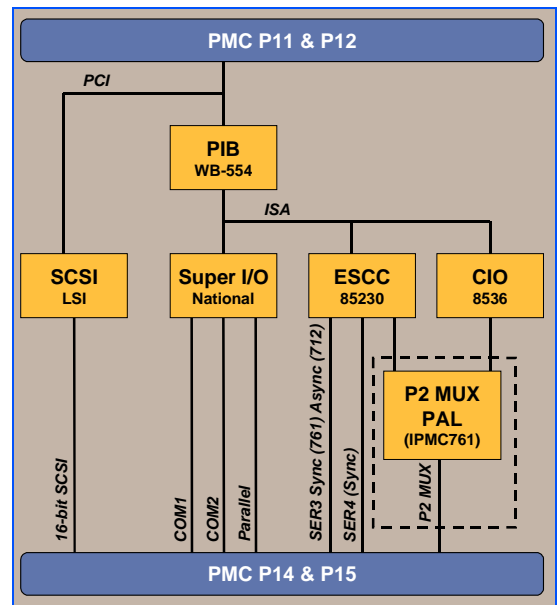

## TRANSITION MODULES

### MVME761

The MVME761 transition module provides industry-standard connector access to the IEEE 1284 parallel port, a 10BaseT or 100BaseTX port via an RJ-45 connector, two DB-9 connectors providing access to the asynchronous serial ports configured as EIA-574 DTE and two HD-26 connectors providing access to the sync/async serial ports. These serial ports, labeled as Serial 3 and Serial 4 on the faceplate of the MVME761, are individually user-configurable as EIA-232, EIA-530, V.35 or X.21 DCE/DTE via the installation of Motorola serial interface modules (SIMs).

A P2 adapter provides interface module signals to the MVME761 transition module. The 3-row P2 adapter can be used for 8-bit SCSI. A 5-row P2 adapter supports 16-bit SCSI and PMC I/O.

### MVME712M

The MVME712M transition module provides industry-standard connector access to the Centronics® parallel port, a narrow SCSI port and four DB-25 connectors providing access to the asynchronous/synchronous serial ports jumper configurable as EIA-232 DCE/DTE. A P2 adapter provides interface signals to the MVME712M transition module. The 3-row P2 adapter can be used for 8-bit SCSI.

To gain access to the additional user-definable I/O pins provided via the 5-row VME64 extension connector, a special P2 adapter board is available. This adapter panel replaces the traditional 3-row P2 adapter and extends its capability by providing access to the PMC I/O pins.

## SOFTWARE SUPPORT

### Firmware Monitor

Firmware must fulfill the traditional functions of test and initialization and provide operating system boot support. The MVME5100 firmware monitor exceeds these requirements with a proven monitor from the embedded VME leader. It expands features like power-up tests with extensive diagnostics, as well as a powerful evaluation and debug tool for simple checkout or when high-level development debuggers require additional support. All this is included with the MVME5100 firmware; plus it supports booting both operating systems and kernels.

### Operating Systems and Kernels

MVME5100 supports booting a variety of operating systems:

**Wind River Systems, Inc.:** VxWorks

**Green Hills:** Integrity

**Multiple Partners:** Linux

### Diagnostic Software

Motorola Built-In Test (MBIT) is an off-the-shelf software infrastructure designed to verify the correct operation of Motorola hardware and enable the incorporation of system level diagnostics. A comprehensive User Manual with software development guidelines is provided on MBIT's CD-ROM. Two versions of MBIT are available and are compatible with Wind River Systems Tornado 2.1.

- Board level MBIT is a comprehensive diagnostic software package designed to verify the performance of board mounted logic devices. All tests can execute at boot-up and selected tests can run continuously in the background of user applications. An API is included to provide access to test results and to modify and control the operation of device tests.
- System level MBIT includes all functionality and API function calls of the board level version and enables system-wide testing. System Level MBIT provides a framework and additional API function calls to support the inclusion of software designed to test custom hardware and/or system components.

## SPECIFICATIONS

### MVME5100 Processor Module

#### Processors

<b>Microprocessor:</b>	MPC7410	MPC750 class	MPC755 class
<b>Clock Frequency:</b>	400 or 500 MHz	450 MHz	400 MHz
<b>On-chip Cache (I/D):</b>	32K/32K	32K/32K	32K/32K
<b>Secondary Cache:</b>	2MB	1MB	1MB

#### Main Memory

<b>Type:</b>	PC100 ECC SDRAM with 100 MHz bus
<b>Capacity:</b>	Up to 512MB on-board, expandable to 1GB with RAM500 memory mezzanines
<b>Single Cycle Accesses:</b>	10 Read/5 Write
<b>Read Burst Mode:</b>	7-1-1-1 idle; 2-1-1-1 aligned page hit
<b>Write Burst Mode:</b>	4-1-1-1 idle; 2-1-1-1 aligned page hit
<b>Architecture:</b>	64-bit, single interleave

#### Flash Memory

<b>Type:</b>	EEPROM, on-board programmable
<b>Capacity:</b>	1MB via two 32-pin PLCC/CLCC sockets; 16MB surface mount
<b>Read Access (16MB port):</b>	70 clocks (32-byte burst)
<b>Read Access (1MB port):</b>	262 clocks (32-byte burst)

#### NVRAM

<b>Capacity:</b>	32KB (4KB available for users)
<b>Cell Storage Life:</b>	50 years at 55° C
<b>Cell Capacity Life:</b>	5 years at 100% duty cycle, 25°C
<b>Removable Battery:</b>	Yes

#### VMEbus ANSI/VITA 1-1994 VME64 (IEEE STD 1014)

<b>Controller:</b>	Tundra Universe
<b>DTB Master:</b>	A16–A32; D08–D64, BLT
<b>DTB Slave:</b>	A24–A32; D08–D64, BLT, UAT
<b>Arbiter:</b>	RR/PRI
<b>Interrupt Handler/Generator:</b>	IRQ 1–7/Any one of seven IRQs
<b>System Controller:</b>	Yes, jumperable or auto detect
<b>Location Monitor:</b>	Two, LMA32

#### Counters/Timers

<b>TOD Clock Device:</b>	M48T37V
<b>Real-Time Timers/Counters:</b>	Four, 32-bit programmable
<b>Watchdog Timer:</b>	Time-out generates reset

#### Ethernet Interface

<b>Controller:</b>	Two Intel 82559ER
<b>Interface Speed:</b>	10/100Mb/s
<b>PCI Local bus DMA:</b>	Yes, with PCI burst
<b>Connector:</b>	One routed to front panel RJ-45, one routed to front panel RJ-45 or optionally routed to P2, RJ-45 on MVME761

#### Asynchronous Serial Ports

<b>Controller:</b>	16C550C UART
<b>Number of Ports:</b>	Two, 16550 compatible
<b>Configuration:</b>	EIA-574 DTE
<b>Async Baud Rate, bps max.:</b>	38.4K EIA-232, 115Kbps raw
<b>Connector:</b>	One routed to front panel RJ-45, one on planar for development use

#### Dual IEEE P1386.1 PCI Mezzanine Card Slots

<b>Address/Data:</b>	A32/D32/D64, PMC PN1, PN2, PN3, PN4 connectors
<b>PCI Bus Clock:</b>	33 MHz
<b>Signaling:</b>	5V
<b>Power:</b>	+3.3V, +5V, ±12V; 7.5 watts maximum per PMC slot
<b>Module Types:</b>	Two single-wide or one double-wide, front panel or P2 I/O

#### PCI Expansion Connector

<b>Address/Data:</b>	A32/D32/D64
<b>PCI Bus Clock:</b>	33 MHz
<b>Signaling:</b>	5V
<b>Connector:</b>	114-pin connector located on the planar of the MVME5100

## Power Requirements

(not including power required by PMC or IPMC modules)

	<b>+5 V ± 5%</b>	<b>+12 V ± 10%</b>	<b>-12 V ± 10%</b>
<b>MVME5100:</b>	3.0 A typ.	8.0 mA typ.	2.0 mA typ.

## Board Size

<b>Height:</b>	233.4 mm (9.2 in.)
<b>Depth:</b>	160.0 mm (6.3 in.)
<b>Front Panel Height:</b>	261.8 mm (10.3 in.)
<b>Width:</b>	19.8 mm (0.8 in.)
<b>Max. Component Height:</b>	14.8 mm (0.58 in.)

## IPMC Modules

### PMC Interface

<b>Address/Data:</b>	A32/D32/D64, PMC PN1, PN2, PN3, PN4 connectors
<b>PCI Bus Clock:</b>	33 MHz
<b>Signaling:</b>	5V
<b>Module Type:</b>	Basic, single-wide; P2 I/O

### SCSI Bus

<b>Controller:</b>	Symbios 53C895A
<b>PCI Local Bus DMA:</b>	Yes, with PCI local bus burst
<b>Asynchronous (8-bit mode):</b>	5.0MB/s
<b>Ultra SCSI:</b>	20.0MB/s (8-bit mode), 40.0MB/s (16-bit mode)

Note: 16-bit SCSI operation precludes the use of some PMC slot 2 signals.

### Synchronous Serial Ports

<b>Controller:</b>	85230/8536
<b>Number of Ports:</b>	Two (IPMC761); one (IPMC712)
<b>Configuration:</b>	IPMC761: TTL to P2 (both ports), SIM configurable on MVME761; IPMC712: EIA-232 to P2
<b>Baud Rate, bps max.:</b>	2.5M sync, 38.4K async
<b>Oscillator Clock Rate (PCLK):</b>	10 MHz/5 MHz

### Asynchronous Serial Ports

<b>Controller:</b>	16C550 UART; 85230/8536
<b>Number of Ports:</b>	Two (IPMC761); three (IPMC712)
<b>Configuration:</b>	EIA-574 DTE (IPMC761); EIA-232 (IPMC712)
<b>Async Baud Rate, bps max.:</b>	38.4K EIA-232, 115Kbps raw

### Parallel Port

<b>Controller:</b>	PC97307
<b>Configuration:</b>	8-bit bi-directional, full IEEE 1284 support; Centronics compatible (minus EPP and ECP on MVME712M)
<b>Modes:</b>	Master only

### Power Requirements

(additional power load placed on MVME5100 Series with IPMC installed)

	<b>+5V ± 5%</b>	<b>+12V ± 10%</b>	<b>-12V ± 10%</b>
<b>MVME5100:</b>	3.8 A max. 3.0 A typ.	8.0 mA typ.	2.0 mA typ.
<b>MVME5106:</b>	3.8 A max. 2.6 A typ.	8.0 mA typ.	2.0 mA typ.
<b>MVME5107:</b>	4.7 A max. 3.5 A typ.	8.0 mA typ.	2.0 mA typ.
<b>MVME5110-21xx:</b>	3.8 A max. 3.1 A typ.	8.0 mA typ.	2.0 mA typ.
<b>MVME5110-22xx:</b>	4.7 A max. 3.5 A typ.	8.0 mA typ.	2.0 mA typ.

## Transition Modules

### I/O Connectors

	<b>MVME761</b>	<b>MVME712M</b>
<b>Asynchronous Serial Ports:</b>	Two, DB-9 labeled as COM1 and COM2	Three, DB-25 labeled as Serial 1, Serial 2 and Serial 3
<b>Synchronous Serial Ports:</b>	Two HD-26 labeled as Serial 3 and Serial 4 (user configurable via installation of SIMs), two 60-pin connectors on MVME761 planar for installation of two SIMs	One, DB-25 labeled as Serial 4
<b>Parallel Port:</b>	HD-36, Centronics compatible	D-36, Centronics compatible
<b>Ethernet:</b>	10BaseT or 100BaseTX, RJ-45	not available
<b>SCSI:</b>	8- or 16-bit, 50- or 68-pin connector via P2 adapter	8-bit, standard SCSI D-50

## All Modules

## Environmental

(Minimum of 400 LFM of forced air cooling is recommended for operation in the higher temperature ranges.)

	<b>Operating</b>	<b>Nonoperating</b>
<b>Commercial Temperature:</b>	0° C to +55° C (inlet air temp. w/forced air cooling)	-40° C to +85° C
<b>Extended Temperature:</b>	-20° C to +71° C	-40° C to +85° C
<b>Humidity (NC):</b>	5% to 90%	5% to 90%
<b>Vibration:</b>	2 Gs RMS, 20–2000 Hz random	6 Gs RMS, 20–2000 Hz random

## Electromagnetic Compatibility (EMC)

Intended for use in systems meeting the following regulations:

**U.S.:** FCC Part 15, Subpart B, Class A (non-residential)

**Canada:** ICES-003, Class A (non-residential)

This product was tested in a representative system to the following standards:

CE Mark per European EMC Directive 89/336/EEC with Amendments; Emissions: EN55022 Class B; Immunity: EN55024

## Safety

All printed wiring boards (PWBs) are manufactured with a flammability rating of 94V-0 by UL recognized manufacturers.

## Demonstrated MTBF

(based on a sample of eight boards in accelerated stress environment)

**Mean:** 190,509 hours

**95% Confidence:** 107,681 hours

## ORDERING INFORMATION

All models of the MVME51xx are available with either VME Scanbe front panel (-xxx1) or IEEE 1101 compatible front panel (-xxx3).

Part Number	Description
<b>450 MHz MPC750 Commercial Models</b>	
<b>MVME5100-016x</b>	450 MHz MPC750, 512MB ECC SDRAM, 17MB Flash and 1MB L2 cache
<b>400 MHz MPC755 Extended Temperature Models</b>	
<b>MVME5106-114x</b>	400 MHz MPC755, 128MB ECC SDRAM, 17MB Flash and 1MB L2 cache
<b>MVME5106-115x</b>	400 MHz MPC755, 256MB ECC SDRAM, 17MB Flash and 1MB L2 cache
<b>MVME5106-116x</b>	400 MHz MPC755, 512MB ECC SDRAM, 17MB Flash and 1MB L2 cache
<b>400 and 500 MHz MPC7410 Commercial Models</b>	
<b>MVME5110-216x</b>	400 MHz MPC7410, 512MB ECC SDRAM, 17MB Flash and 2MB L2 cache
<b>MVME5110-226x</b>	500 MHz MPC7410, 512MB ECC SDRAM, 17MB Flash and 2MB L2 cache
<b>500 MHz MPC7410 Extended Temperature Models</b>	
<b>MVME5107-214x</b>	500 MHz MPC7410, 128MB ECC SDRAM, 17MB Flash and 2MB L2 cache
<b>MVME5107-215x</b>	500 MHz MPC7410, 256MB ECC SDRAM, 17MB Flash and 2MB L2 cache
<b>MVME5107-216x</b>	500 MHz MPC7410, 512MB ECC SDRAM, 17MB Flash and 2MB L2 cache
<b>MVME712M Compatible I/O</b>	
<b>IPMC712-001</b>	Multifunction rear I/O PMC module; 8-bit SCSI, Ultra Wide SCSI, one parallel port, three async and one sync/async serial ports
<b>MVME712M</b>	Transition module connectors: One DB-25 sync/async serial port, three DB-25 async serial port, one AUI connector, one D-36 parallel port, and one 50-pin 8-bit SCSI; includes 3-row DIN P2 adapter module and cable

<b>MVME761 Compatible I/O</b>	
<b>IPMC761-001</b>	Multifunction rear I/O PMC module; 8-bit SCSI, one parallel port, two async and two sync/async serial ports
<b>MVME761-001</b>	Transition module: Two DB-9 async serial port connectors, two HD-26 sync/async serial port connectors, one HD-36 parallel port connector, one RJ-45 10/100 Ethernet connector; includes 3-row DIN P2 adapter module and cable (for 8-bit SCSI)
<b>MVME761-011</b>	Transition module: Two DB-9 async serial port connectors, two HD-26 sync/async serial port connectors, one HD-36 parallel port connector, and one RJ-45 10/100 Ethernet connector; includes 5-row DIN P2 adapter module and cable (for 16-bit SCSI); requires backplane with 5-row DIN connectors
<b>SIM232DCE or DTE</b>	EIA-232 DCE or DTE Serial Interface Module
<b>SIM530DCE or DTE</b>	EIA-530 DCE or DTE Serial Interface Module
<b>SIMV35DCE or DTE</b>	V.35 DCE or DTE Module
<b>SIMX21DCE or DTE</b>	X.21 DCE or DTE Serial Interface Module
<b>Related Products</b>	
<b>PMCSAN1-002</b>	PMCSAN-002 with original VME Scanbe ejector handles
<b>PMCSAN1-010</b>	PMCSAN-010 with original VME Scanbe ejector handles
<b>RAM500-004</b>	Stackable (top) 64MB ECC SDRAM mezzanine
<b>RAM500-006</b>	Stackable (top) 256MB ECC SDRAM mezzanine
<b>RAM500-016</b>	Stackable (bottom) 256MB ECC SDRAM mezzanine
<b>Documentation</b>	
<b>V5100A/IH</b>	MVME5100 Installation and Use
<b>V5100A/PG</b>	Programmer's Reference Guide
<b>VME761A/IH</b>	MVME761 Transition Module Installation and Use
<b>VME712MA/IH</b>	MVME712 Transition Module Installation and Use
<b>PPCBUGA1/UM</b> <b>PPCBUGA2/UM</b>	PPC Bug Firmware Package User's Manual (volumes one and two)
<b>PPCDIAA/UM</b>	PPC Bug Diagnostics Manual
Documentation is available for online viewing and ordering at <a href="http://www.motorola.com/computer/literature">http://www.motorola.com/computer/literature</a>	

**Motorola Computer Group  
Regional Offices**

NORTH AMERICA: Tempe, AZ 800-759-1107 or 602-438-5720  
EUROPE: Loughborough, UK +44 1509 634300  
EAST MEDITERRANEAN: Tel Aviv, Israel +972 3 568 4388

ASIA: Shanghai, China +86 21 5292 5693  
PACIFIC RIM: Tokyo, Japan +81 3 5424 3101  
ASIA/PACIFIC: Hong Kong +852 2966 3210



[www.motorola.com/computer](http://www.motorola.com/computer)

MOTOROLA and the Stylized M Logo are registered in the U.S. Patent and Trademark Office. All other product or service names are the property of their respective owners.

© Motorola Inc. 1999, 2000, 2001, 2002

This datasheet identifies products, their specifications, and their characteristics, which may be suitable for certain applications. It does not constitute an offer to sell or a commitment of present or future availability, and should not be relied upon to state the terms and conditions, including warranties and disclaimers thereof, on which Motorola may sell products. A prospective buyer should exercise its own independent judgement to confirm the suitability of the products for particular applications. Motorola reserves the right to make changes, without notice, to any products or information herein which will, in its sole discretion, improve reliability, function, or design. Motorola does not assume any liability arising out of the application or use of any product or circuit described herein; neither does it convey any license under its patent or other intellectual property rights or under others. This disclaimer extends to any prospective buyer, and it includes Motorola's licensee, licensee's transferees, and licensee's customers and users. Availability of some of the products and services described herein may be restricted in some locations.