

## 12.1 RUSIO-3224

### 12.1.1 Universal Safe IO device (32 channels, 24 V DC)

The RUSIO-3224 module has 32 universal safe IO channels with configurable channel function; configuration is done in Safety Builder.

The RUSIO-3224 module can be used in applications up to SIL 3, in compliance with IEC 61508/61511.

It requires two RUSIO-3224 modules to achieve a redundant configuration.

All channels are powered out of the 24 V DC supply.

Each channel can be configured as:

- Digital input (with or without loop monitoring)
- Digital output (with loop monitoring)
- Analog input (0-20 mA or 4-20 mA active)
- Analog output (0-20 mA or 4-20 mA active)

The RUSIO-3224 module supports two (100Mbaud) ethernet links to communicate with a Safety Manager Controller.

The RUSIO-3224 module has a housing that is in line with the patented Series C design of Honeywell. It needs to be placed on an IO Termination Assembly (IOTA).

The below figure shows physical appearance of the RUSIO-3224 module.

12 Universal Safety IO

12.1 RUSIO-3224

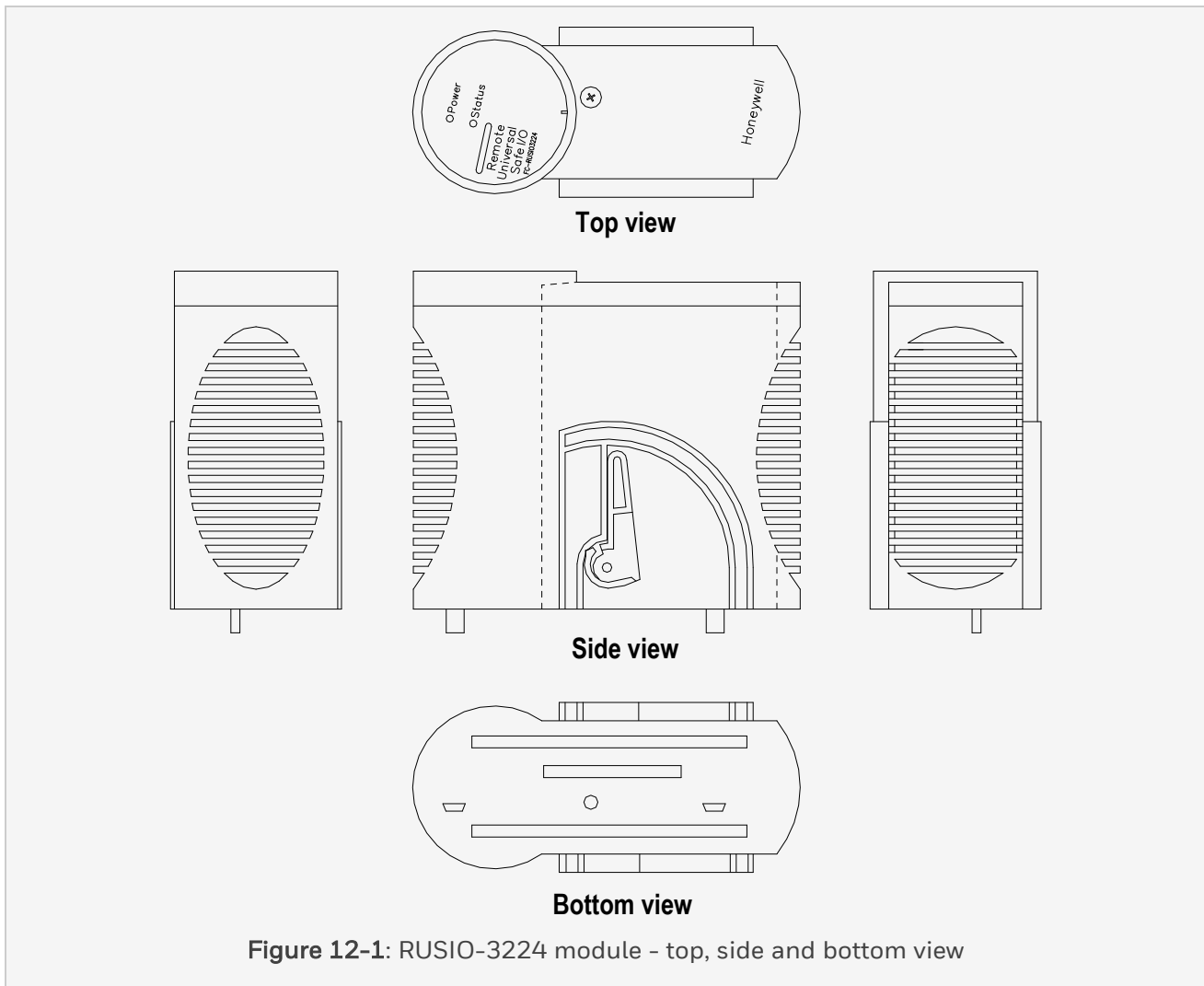

The RUSIO-3224 module has the following features:

- 32 universal IO channels that can be configured to control DI, AI, DO, AO
- Any type of IO field signal has only to be connected to the two connections of the applicable universal channel on the IOTA
- Proven-in-use redundant processor concept that complies with the SIL 3 safety requirements in single channel operation
- A dedicated communication link between these processors
- A redundant communication link with the partner module (in redundant configuration)

- An Ethernet-based Safety Manager Universal I/O link to the Safety Manager Controller in the network via dedicated switches; the Safety Manager Universal I/O link uses a dedicated protocol
- Monitoring the temperature of the electronics
- A configurable ESD function via channel 32 for dedicated safety related functions
- Function-tested watchdogs that: monitor and/or handle:
  - monitor cycle time and supply voltage
  - handle the ESD function and memory errors
- LED indicators at the front of the module for power and health status indication
- Real-time clock for Sequence Of Event (SOE) time stamping with a resolution of 1 msec

The RUSIO-3224 module functions as a Safety Manager universal IO module within the Safety Manager concept. It executes:

- The input scan of the process variables
- All functional tests of its hardware
- Data exchange with its partner module
- Data exchange via the Safety Manager Universal I/O link with the Safety Manager Controller that executes the application logics
- Update the outputs and thus the process

The FLASH nature of the memory allows for on line upgrading within the TÜV-approved concept of both the system software as well as the channel configuration.

12 Universal Safety IO

12.1 RUSIO-3224

**12.1.2 Power and status indications**

The RUSIO-3224 module has two LEDs; one for power indication and one for status indication (see the below figure).

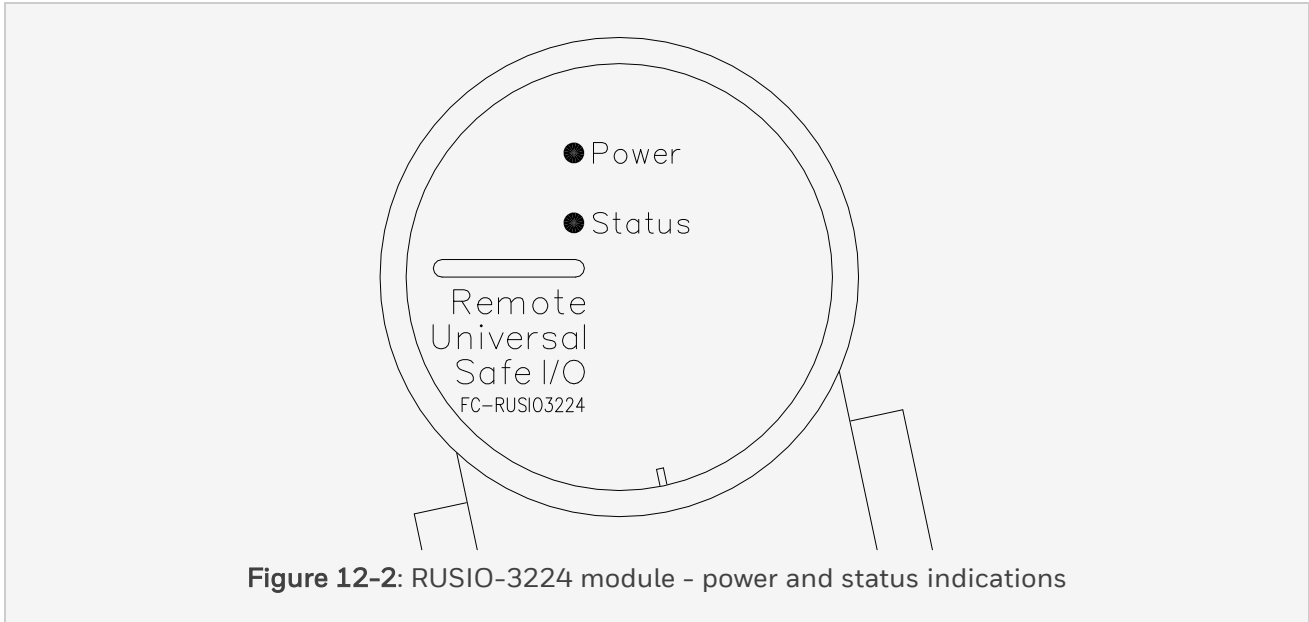

**Figure 12-2:** RUSIO-3224 module - power and status indications

The table below specifies the applicable indications:

LED indication		Status
Power LED	Green, steady	Power to the module is switched on
	Off	Power to the module is switched off
Status LED	Green, steady	Running without hardware fault
	Red, steady	Running with hardware fault(s)
	Green, flashing, toggle 1 Hz	Idle without hardware fault
	Red, flashing, toggle 1 Hz	Idle with hardware fault(s)
	Red, flashing, toggle 4 Hz	Application / firmware loading
	Off	Module has stopped

### 12.1.3 ESD function

The RUSIO-3224 module has one channel that can be configured as Emergency ShutDown (ESD) input; this is channel 32. To configure channel 32 as ESD input in Safety Builder, the two pins fork on the CN4 terminals on the IOTA must be in the ENABLE position (connecting pins 1 and 2).

Channel 32 must be configured for the ESD function in the software also, in order to execute the proper tests for the ESD channel.

When the (field) switch on the ESD input opens, the Safety Manager universal IO watchdogs switch off and all digital outputs of the connected RUSIO-3224 module(s) will go off and remain off. There is *no* software action required to do this; also there is no software action that can prevent this.

See detail A of the "ESD input of a Safety Manager universal IO channel" below for a block diagram of this ESD input.

See detail B of the "ESD input of a Safety Manager universal IO channel" below for the ESD input field connection.

The ESD input is line monitored (for short circuit in the field wires).

Place the (1 kOhm) line termination resistor on (or near) the switch.

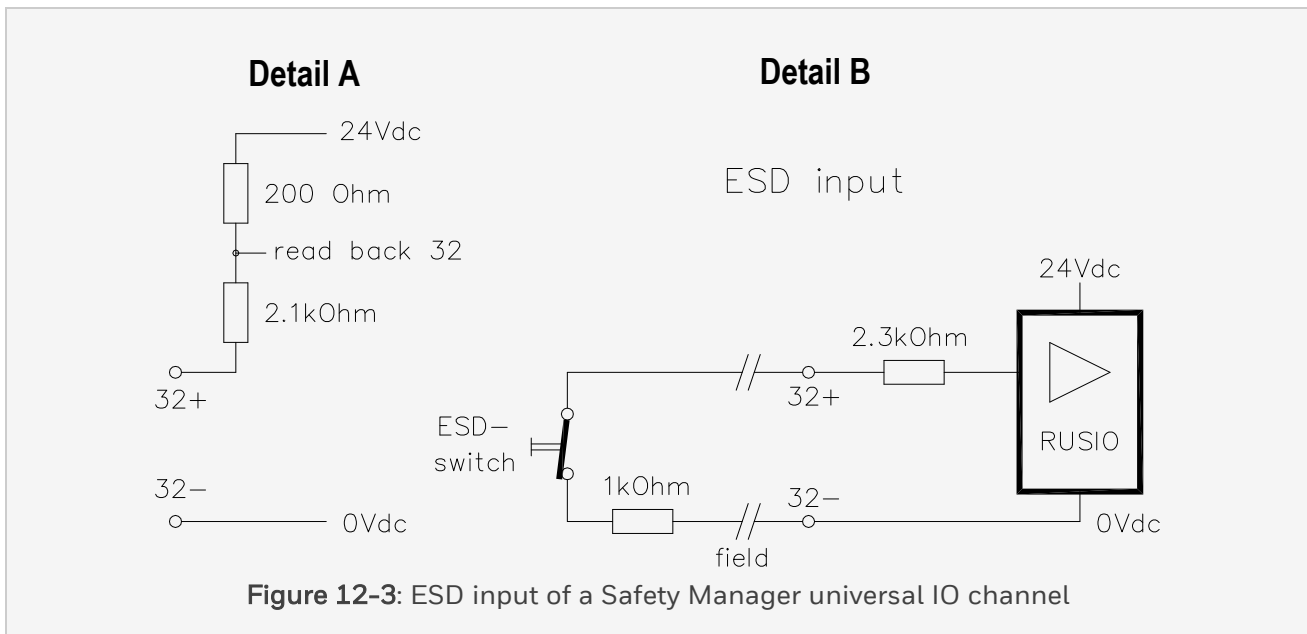

Connecting multiple ESD-inputs of RUSIO-3224 modules with one switch requires a 7.5 Volt zener, see the "ESD switch to multiple Safety Manager universal IO modules" on the next page.

## 12 Universal Safety IO

### 12.1 RUSIO-3224

All RUSIO-3224 modules involved must be supplied out of the same 24 V DC (power rail).

A 1 Watt zenerdiode - like the 1N4737A or the BZV85-C7V5 - can handle upto 10 ESD inputs of (redundant) RUSIO-3224 modules.

A 5 Watt zenerdiode - like the 1N5343B - can handle upto 50 ESD inputs of (redundant) RUSIO-3224 modules.

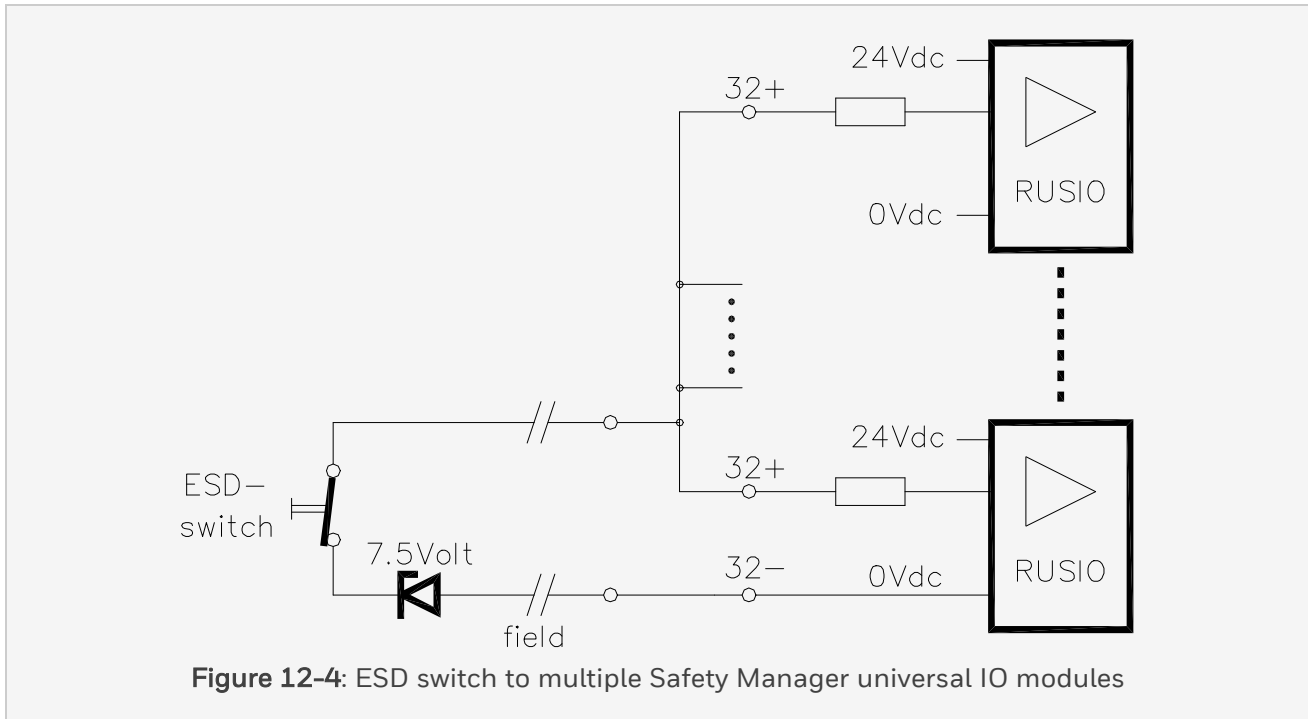

### 12.1.3.1 Technical Data for an ESD input

Open voltage:	24 V DC -20% ... +30%
Closed contact current:	7 mA $\pm$ 5% (at 24 V DC)
Switch resistor (single):	1 kOhm $\pm$ 5% >0.25 W
Switch zener (multiple):	7.5 Volt
Open contact current:	< 4 mA $\pm$ 5%
Short circuit detection:	field resistance < 500 Ohm $\pm$ 50%
ESD to outputs off delay:	10 ms $\pm$ 30%

### 12.1.4 IO channels

The RUSIO-3224 module has 32 remote universal safe IO channels.

One RUSIO-3224 module can be placed on a non-redundant IOTA to establish 32 non-redundant channels. Two RUSIO-3224 modules can be placed on one redundant IOTA to establish 32 redundant universal safe IO channels.

Each channel has two screw positions for the connection of field wires on the IOTA. No additional connections for field devices are required.

Positions 1+ through 32+ are the signal connections; one for each of the channels.

Positions 1- through 32- are (all) directly connected with the 0Vdc supply connection.

All channels are 24Vdc sourcing (“active”).

Each channel can be configured as (line monitored) input or output. Some channels have additional configuration features. In the next topics the features and specific technical data of the various configurations are described. The topic titles reflect the function that a channel will have once it is configured.

12 Universal Safety IO

12.1 RUSIO-3224

12.1.4.1 Line-monitored digital input

The line-monitored input of the RUSIO-3224 module consists of a 250 Ohm resistance and an electronic current limiter. See detail A of the "Line-monitored digital input of a Safety Manager universal IO channel" below for a block diagram of this Safety Manager universal IO channel configuration.

A line-monitored digital input requires two resistors in the field, near the switching element.

For Normally Closed (field-)contacts, these resistors must be connected in parallel, close to the switch. See detail B of the "Line-monitored digital input of a Safety Manager universal IO channel" below.

For Normally Open (field-)contacts, these resistors must be connected in series, close to the switch. See detail C of the "Line-monitored digital input of a Safety Manager universal IO channel" below.

Lead-breakage or short circuit in the wires to the switching element will be detected and result in a warning by the RUSIO-3224.

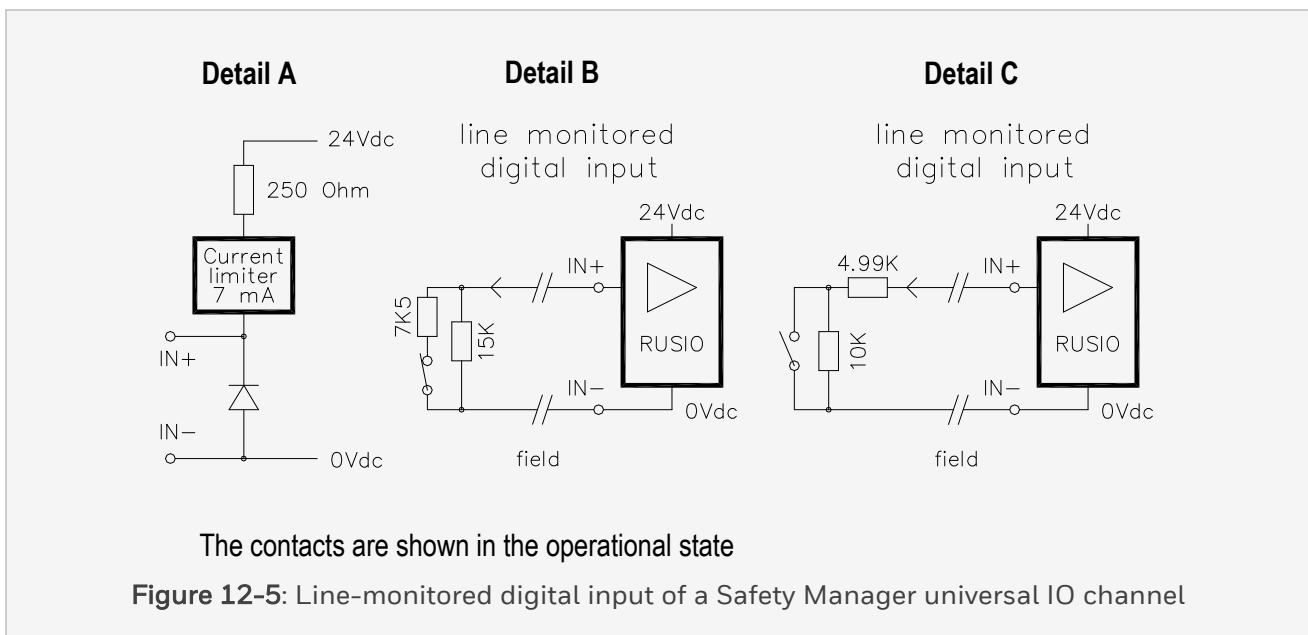

**Technical data for a line-monitored digital input**

All channels	Open voltage:	24 V DC -20% ... +30%
	Short circuit current:	7 mA $\pm$ 5%
	Current limiter voltage drop:	< 1.4 Volt (while NOT limiting)
	Open contact:	15 kOhm $\pm$ 5% >0.1 W
	Closed contact:	5 kOhm $\pm$ 5% >0.25 W
	Short circuit detection:	I > 6.3 mA $\pm$ 5%
	Closed contact detection:	2.8 mA < I < 6.3 mA $\pm$ 5%
	Open contact detection:	0.7 mA < I < 2.1 mA $\pm$ 5%
	Lead breakage detection:	I < 0.7 mA $\pm$ 5%
	Input filter:	first-order low-pass 100 Hz
	Maximum field capacitance:	100 nF

12 Universal Safety IO

12.1 RUSIO-3224

12.1.4.2 Non line-monitored digital input

The non line-monitored input of the RUSIO-3224 module consists of a 250 Ohm resistance and an electronic current limiter. See detail A of the below figure for a block diagram of this Safety Manager universal IO channel configuration.

A non line-monitored digital input has a switching element in the field; see detail B of the below figure.

This input has no short circuit or lead breakage detection.

**Attention:**

Channels configured as non line-monitored digital inputs may not be used as part of a safety loop.

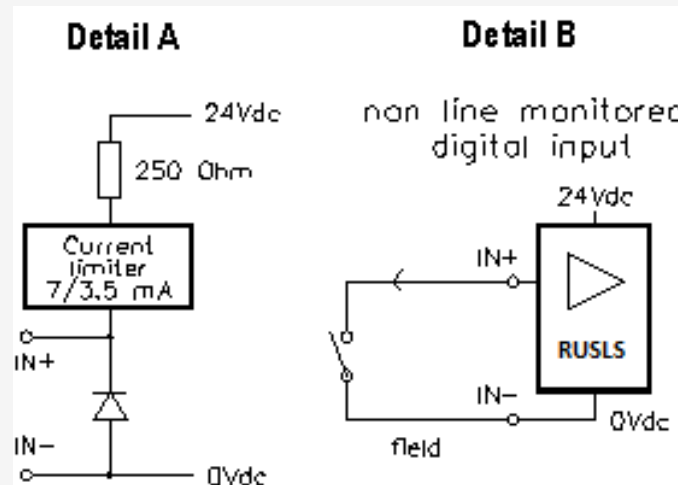

Figure 12-6: Non line-monitored digital input of a Safety Manager universal IO channel

**Technical data for a non line-monitored digital input**

All channels	Open voltage:	24 V DC -20% ... +30%
	Closed contact current:	7 mA ± 5%, after open state detection
		3.5 mA ± 5%, after closed state detection
	Current limiter voltage drop:	< 1.4 Volt (while NOT limiting)
	Closed contact detection:	I > 2.8 mA ± 5%
	Open contact detection:	I < 2.1 mA ± 5%
	Input filter:	first-order low-pass 100 Hz
	Maximum field capacitance:	100 nF

12 Universal Safety IO

12.1 RUSIO-3224

12.1.4.3 Analog input 0-20mA and 4-20mA

The analog input of the RUSIO-3224 module consists of a 250 Ohm resistance and an electronic current limiter. See detail A of the below figure for a block diagram of this Safety Manager universal IO channel configuration.

An analog input is typically connected with a sensor in the field.

That sensor can also be a smoke or fire detector.

See details B and C of the below figure for examples.

A latching smoke or fire detector can be reset by the RUSIO-3224 module without extra components or wires.

It is possible to connect multiple smoke or fire detectors (up to 6) on one channel. Line monitoring and sensor state must be handled in the function block. For a wiring example see detail C of the below figure.

An analog input can be configured for 0-20mA or 4-20mA and is always active (internally sourced out of the 24Vdc supply).

Short circuit in the wires to the sensor will be detected and result in a warning by the RUSIO-3224.

If the input is configured for 4-20mA, then lead breakage of the wires will also be detected and result in a warning by the RUSIO-3224 module.

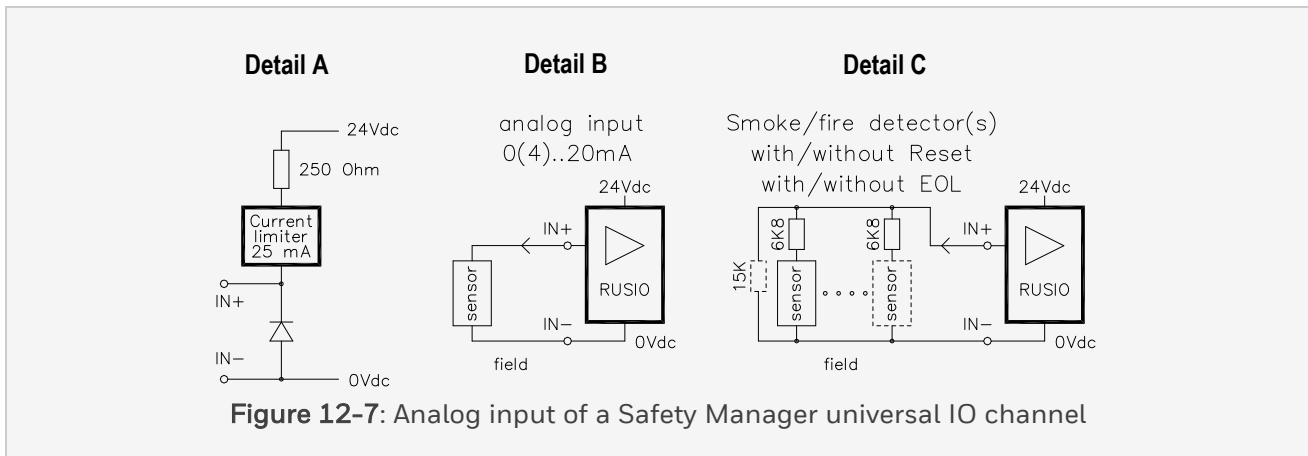

A passive analog Safety Manager universal IO input 0-20mA or 4-20mA can only be created if the current source is isolated. See detail A of the below figure for a block diagram of this Safety Manager universal IO input.

Passive analog Safety Manager universal IO inputs use a V+ pin of CN3 on the IOTA. See detail B of the below figure for an example.

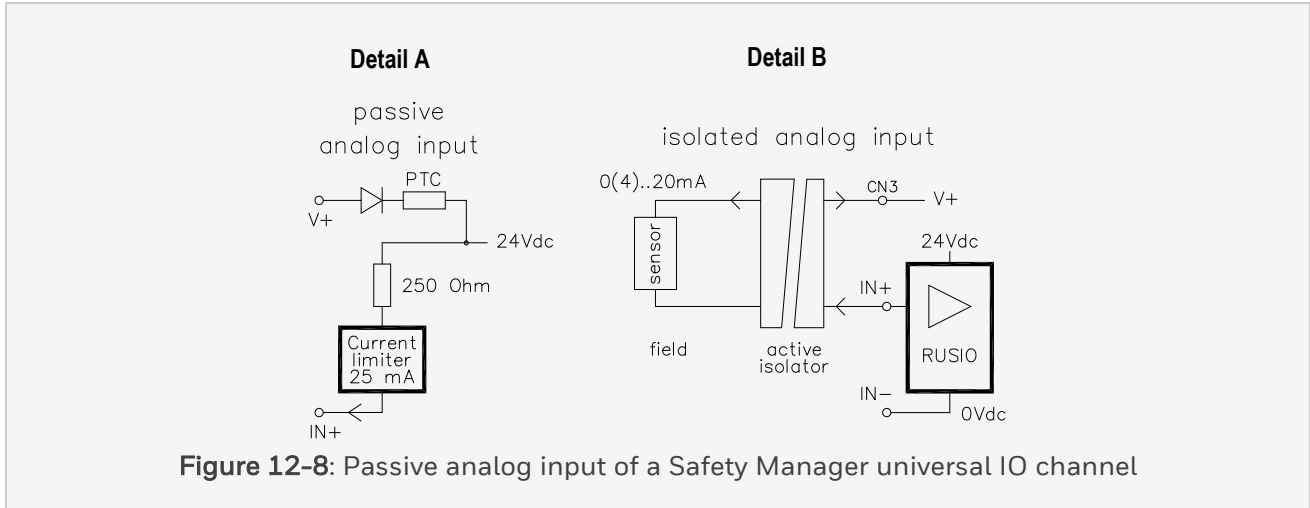

12 Universal Safety IO

12.1 RUSIO-3224

**Technical data for an analog input**

Open voltage:	24 V DC -20% ... +30%
Field voltage:	> 15 V DC (at 0 ... 24 mA)
Short circuit current:	24.5 mA ± 0.5 mA
Input range:	0-20mA or 4-20mA
Input impedance:	typically 250 Ohm
A-D conversion:	16 bit
Typical Inaccuracy	< 0.05%
Worst Case Inaccuracy for 25 degree C	< 0.15%
Worst Case Inaccuracy over full temperature range	< 0.2%
Safety-related inaccuracy:	< 1% of full scale
Input filter:	first-order low-pass 100 Hz
Maximum field capacitance:	100 nF

**Attention:**

- For HART enabled points, the analog transmitter must be configured to operate within the range 2.5 - 22.5 mA. The HART communication will not work if operated outside this range.

The alarm settings for the HART communication also do not work if operated outside this range. In addition, HART communication can be delayed when the analog signal changes from normal operation to alarm state.

- If the alarms on HART devices are communicated by HART messages, alarms are reported as long as the PV value is within the 2.5 and 22.5 mA range.
- If the field device changes the PV value to a value outside the operational range of 4-20 mA so that the alarm value is in between 2.5 and 22.5 mA, HART communication is still possible. However, as HART messages are not used to indicate an alarm this is not a must.

**Note:**

When using the PV value to indicate an alarm, it is recommended to configure the alarm value between 2.5 and 4 mA or between 20 to 22.5 mA to avoid unwanted disturbance.

- All active field devices shall be galvanically separated (isolated) from live voltages. Live voltages are voltages higher than 30Vac or 40Vdc.
- Drawing more than 24 mA will cause extra heat dissipation in the housing of the RUSIO-3224 module. For more information refer to Temperature derating.

#### 12.1.4.4 Digital output

The digital output of the RUSIO-3224 module consists of a (0.5 A current limited) output with a Secondary Means Of De-energisation (SMOD) FET output.

Each output has a SMOD to enable switching off the channel, even if the channel FET fails. See detail A of the below figure for an example.

The output driver limits the output (short circuit) current and switches off the output if an overload condition lasts too long.

All digital outputs of a RUSIO-3224 are off when its IO watchdog is tripped.

12 Universal Safety IO

12.1 RUSIO-3224

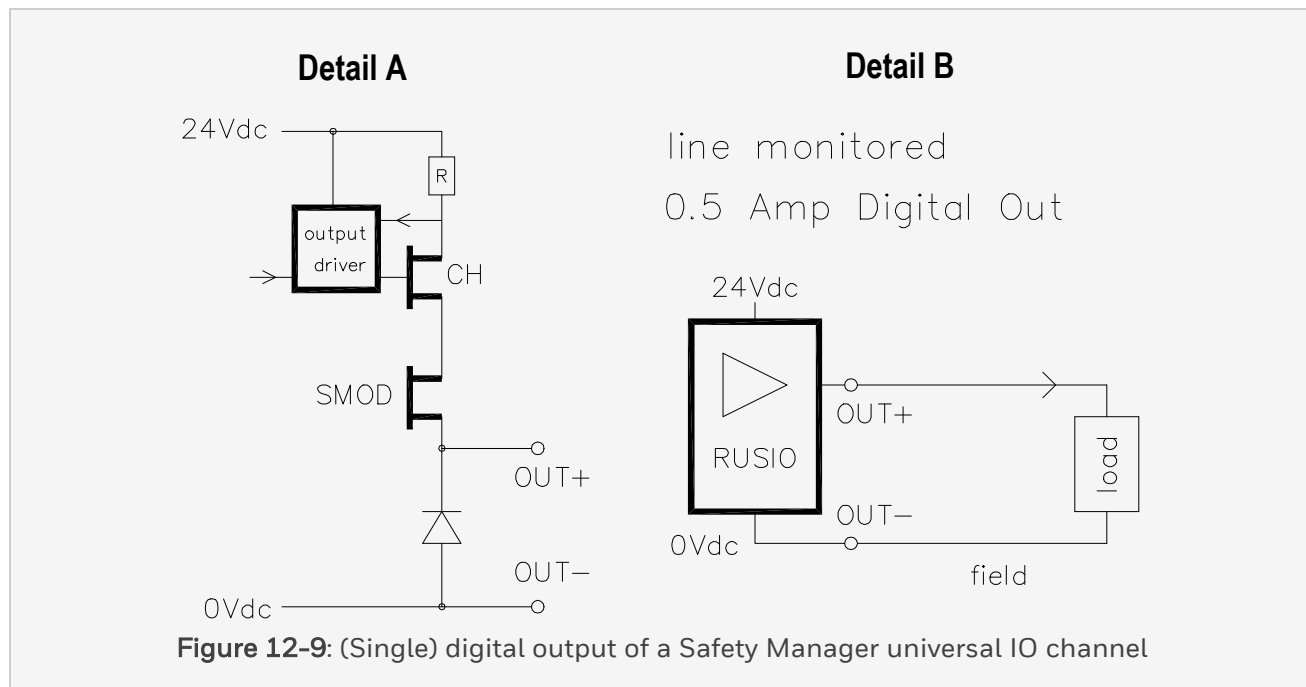

Lead breakage detection in the (field-) wiring is achieved by sourcing a small current (< 0.7 mA) into the field. Failure to conduct this current indicates lead breakage.

Loads of more than 0.5A are supported with the multiple output option.

Sets of two or four outputs can be configured as a multiple output, respectively capable of sourcing up to 1 A or 2 A.

A 2 pins fork with a pitch of 5.08mm (or a 4 pins fork with a pitch of 5.08mm) can be used to interconnect the multiple outputs. See details A and B of the below figure for examples.

The field + wire must be connected with one of the OUT+ pins (together with the fork). Any one of the OUT- pins can be used to connect the field return wire.

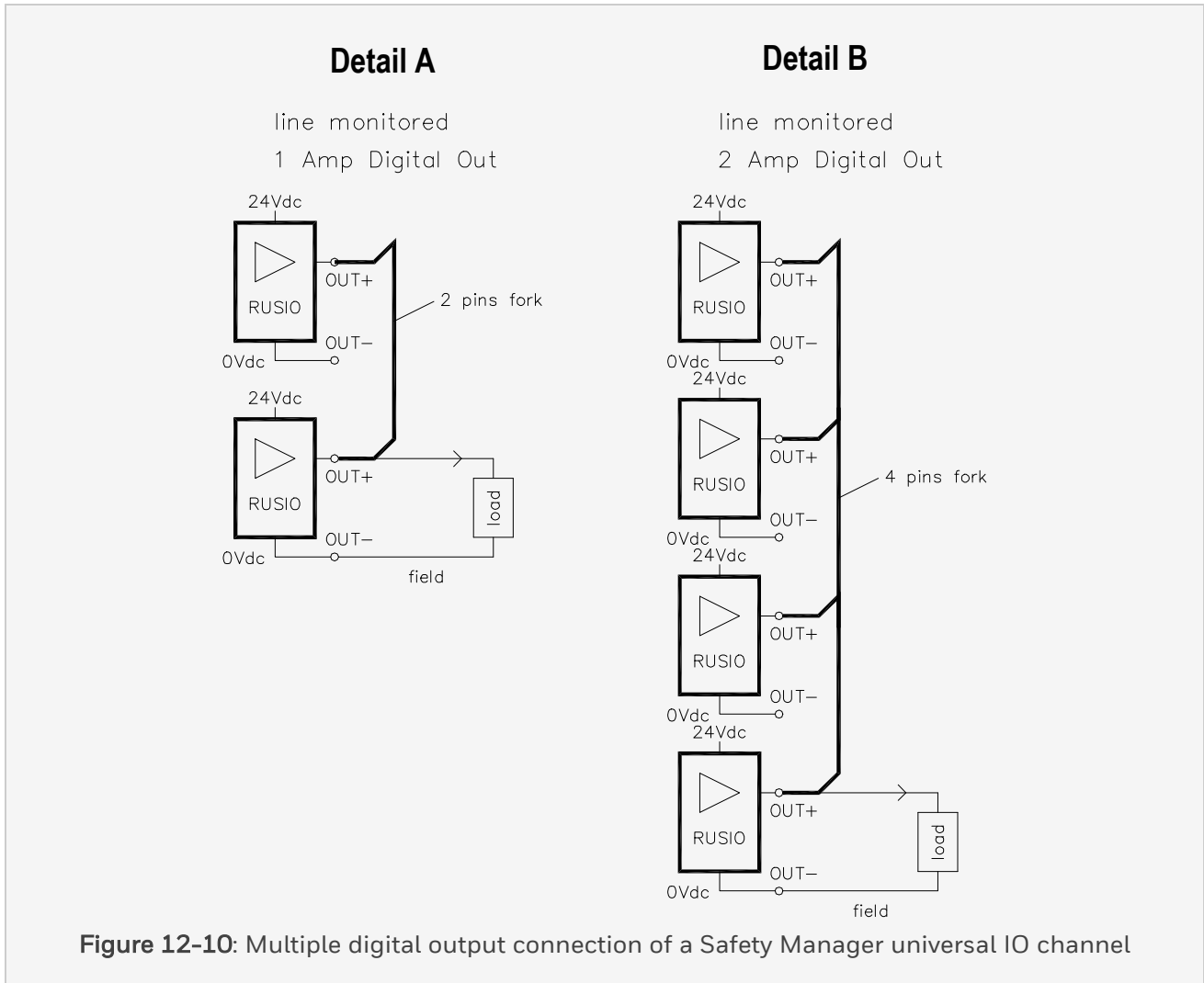

12 Universal Safety IO

12.1 RUSIO-3224

---

**Technical data for a digital output**

Output:	24 V DC solid-state source
	short circuit proof
Maximum resistive load:	500 mA
	<p>For more details see,</p> <ul style="list-style-type: none"> <li>• Open loop detection for de-energized Universal I/O line-monitored digital output channels</li> <li>• General information about output modules</li> </ul>
Maximum tungsten-lamp load:	125mA (3 W)
Minimum load:	1 mA
Maximum field capacitance:	<p>1 <math>\mu</math>F</p> <p>For details, see Open loop detection for de-energized Universal I/O line-monitored digital output channels</p>
Maximum inductive load	10 H
Voltage drop:	< 1.5 V (at 500 mA)
Off current:	< 0.1 mA
Two pins fork:	Weidmuller, LPA QB 2
Four pins fork:	Weidmuller, LPA QB 4

### 12.1.4.5 Analog output 0-20mA and 4-20mA

The analog output of the RUSIO-3224 module consists of a 250 Ohm readback resistor, a current control circuit with output FET (AO) and a SMOD FET. See detail A of the below figure for a block diagram of this Safety Manager universal IO output. Each output has a SMOD to enable switching off the channel, even if the channel FET fails. See details A of the below figure for an example.

An analog output is typically connected with an 0-20mA or 4-20mA analog actuator in the field. See detail B of the below figure for an example.

An analog output can be configured for 0-20mA or 4-20mA and is always active. This means that the RUSIO-3224 module provides the required power.

Short circuit in the wires to the load will not be detected.

If the output is configured for 4-20mA, than lead breakage of the wires will be detected and result in a warning by the RUSIO-3224 module.

Isolated analog output signals require an (Ex-)analog isolator module. See detail C of the below figure for an example of how to connected such an output.

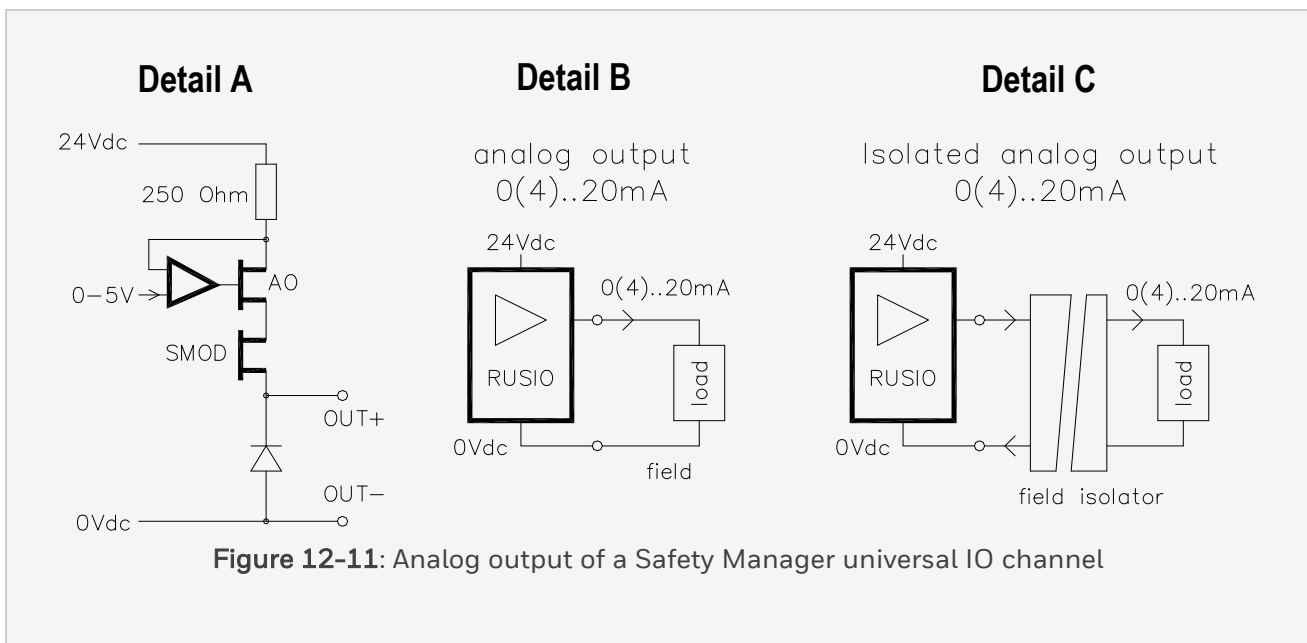

12 Universal Safety IO

12.1 RUSIO-3224

---

**Technical Data for an analog output**

Open voltage:	24 V DC -20% ... +30%
Output current:	0 - 23 mA
Field (loop) resistance:	max. 500 Ohm
Maximum field capacitance:	100 nF
D-A conversion:	12 bit
Inaccuracy:	< 0.5% of full scale
Safety-related inaccuracy	< 1% of full scale

### 12.1.5 Temperature derating

This sub section addresses 'outside module temperature'. The maximum outside module temperature must be limited depending on the internal dissipation.

**Attention:**

1. Airflow in / through the module is assumed to be natural convection.
2. Make sure that RUSIO-3224 modules are installed in the correct position. A RUSIO-3224 module must be mounted in upright position (refer to the "RUSIO-3224 module installation position" below).

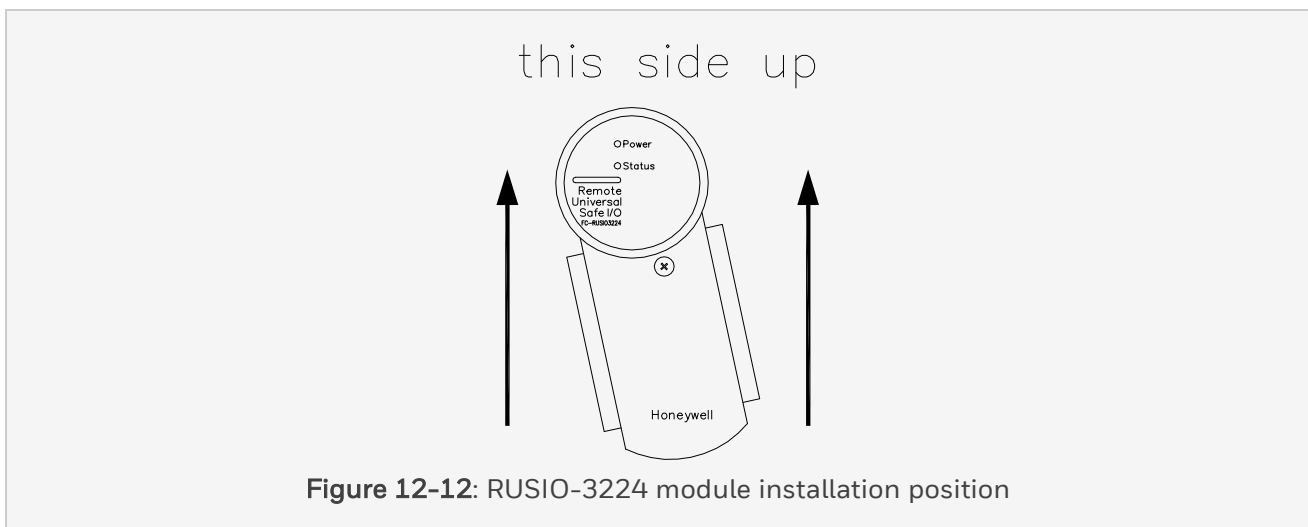

**Figure 12-12:** RUSIO-3224 module installation position

To determine the maximum acceptable outside module temperature for a typical configuration do the steps below. Relevant details are given in separate topics.

12 Universal Safety IO

12.1 RUSIO-3224

Outline of the procedure	For details see
<p>Perform the Internal dissipation calculation.</p> <ol style="list-style-type: none"> <li>1. Determine which supply voltage applies to your configuration:                             <ul style="list-style-type: none"> <li>• 25 V or less</li> <li>• more than 25 V or unknown</li> </ul> </li> <li>2. Select the applicable reference table.</li> <li>3. Determine and record the actual configuration data.</li> <li>4. Calculate the totals per dissipation contributor.</li> <li>5. Add the totals of the previous step to determine the internal dissipation.</li> </ol>	<p>Internal dissipation calculation</p>
<p>Determine the maximum acceptable outside module temperature. Use the applicable derating curve, based on the supply voltage:</p> <ul style="list-style-type: none"> <li>• 25V or less: use the derating curve in "Module derating with a supply voltage of 25 V default" on page 583.</li> <li>• more than 25V or unknown: use the derating curve in "Module derating with a supply voltage of 31.2 V" on page 585.</li> </ul>	<p>"Module derating with a supply voltage of 25 V default" on page 583</p> <p>"Module derating with a supply voltage of 31.2 V" on page 585</p>

**Tip:**

You can make a print of the applicable calculation table to make annotations of your specific configuration(s). Make sure to fill in the table for the applicable supply voltage.

### 12.1.5.1 Internal dissipation calculation

To calculate the maximum outside module temperature, you need the configuration. The maximum dissipation caused by the logic of the RUSIO-3224 module is a fixed value. Other dissipation contributions depend on the channel configuration. The maximum dissipation per channel type depends on the applicable supply voltage.

Select the appropriate table to carry out the calculation, based on the supply voltage:

- 25 V or less: 25 V (default) - as displayed in the Dissipation calculation - supply voltage 25 V table,
- more than 25 V or unknown: 31.2 V (maximum) - as displayed in the Dissipation calculation - supply voltage more than 25 V table.

12 Universal Safety IO

12.1 RUSIO-3224

**Table 1. Dissipation calculation - supply voltage 25 V**

Dissipation contributor (P)	Max. dissipation per channel [W]	Number of configured channels	Dissipation [W]
Logic			5.5
DI-LM; field impedance $\geq 5$ KOhm	0.01		
DI; closed contact; 3.5 mA	0.085		
AI; < 24 mA; Current limited by field	0.05		
AI; > 24 mA; Current limited by RUSIO <sup>1</sup>	0.49		
DO; <0.3 A	0.115		
DO; <0.5 A	0.305		
AO; 500 Ohm field impedance; < 23 mA	0.225		
AO; 250 Ohm field impedance; < 23 mA	0.335		
AO; < 250 Ohm; < 23 mA	0.47		
AO; < 250 Ohm; < 20 mA	0.42		
Total Power Dissipation (TPD) [W]			
Max. outside module temperature [°C]			
<p>1. Analogue input currents above 24 mA should be avoided. Field devices for the analogue input should be configured to drive currents below 24 mA, e.g. 3.5 mA for sensor fault conditions to minimize the Safety Manager universal IO internal power dissipation. The thin-line derating curve needs to be taken when using currents above 24 mA.</p>			

Good practice for the high dissipating channels is:

1. To distribute them over the two IO boards in the module between CH1-16 and CH17-32.
2. To select the channels at the bottom of the IO boards (near CH16 and CH32).

**Table 2. Dissipation calculation - supply voltage more than 25 V**

Dissipation contributor (P)	Max. dissipation per channel [W]	Number of configured channels	Dissipation [W]
Logic			5.5
DI-LM; field impedance $\geq 5$ KOhm	0.01		
DI; closed contact; 3.5 mA	0.085		
AI; < 24 mA; Current limited by field	0.05		
AI; > 24 mA; Current limited by RUSIO <sup>1</sup>	0.64		
DO; <0.3 A	0.115		
DO; <0.5 A	0.305		
AO; 500 Ohm field impedance; < 23 mA	0.345		
AO; 250 Ohm field impedance; < 23 mA	0.48		
AO; < 250 Ohm; < 23 mA	0.61		
AO; < 250 Ohm; < 20 mA	0.545		
Total Power Dissipation (TPD) [W]			
Max. outside module temperature [°C]			
<p>1. Analogue input currents above 24mA should be avoided. Field devices for the analogue input should be configured to drive currents below 24 mA, e.g. 3.5 mA for sensor fault conditions to minimize the Safety Manager universal IO internal power dissipation. The thin-line derating curve needs to be taken when using currents above 24 mA.</p>			

Good practice for the high dissipating channels is:

1. To distribute them over the two IO boards in the module between CH1-16 and CH17-32.
2. To select the channels at the bottom of the IO boards (near CH16 and CH32).

12 Universal Safety IO

12.1 RUSIO-3224

12.1.5.2 Temperature derating curves (25 V supply voltage)

The below figure shows the maximum outside module temperature versus the internal power dissipation. It shows the derating curves for 25 V supply voltage.

An example calculation for this supply voltage is given in the below table.

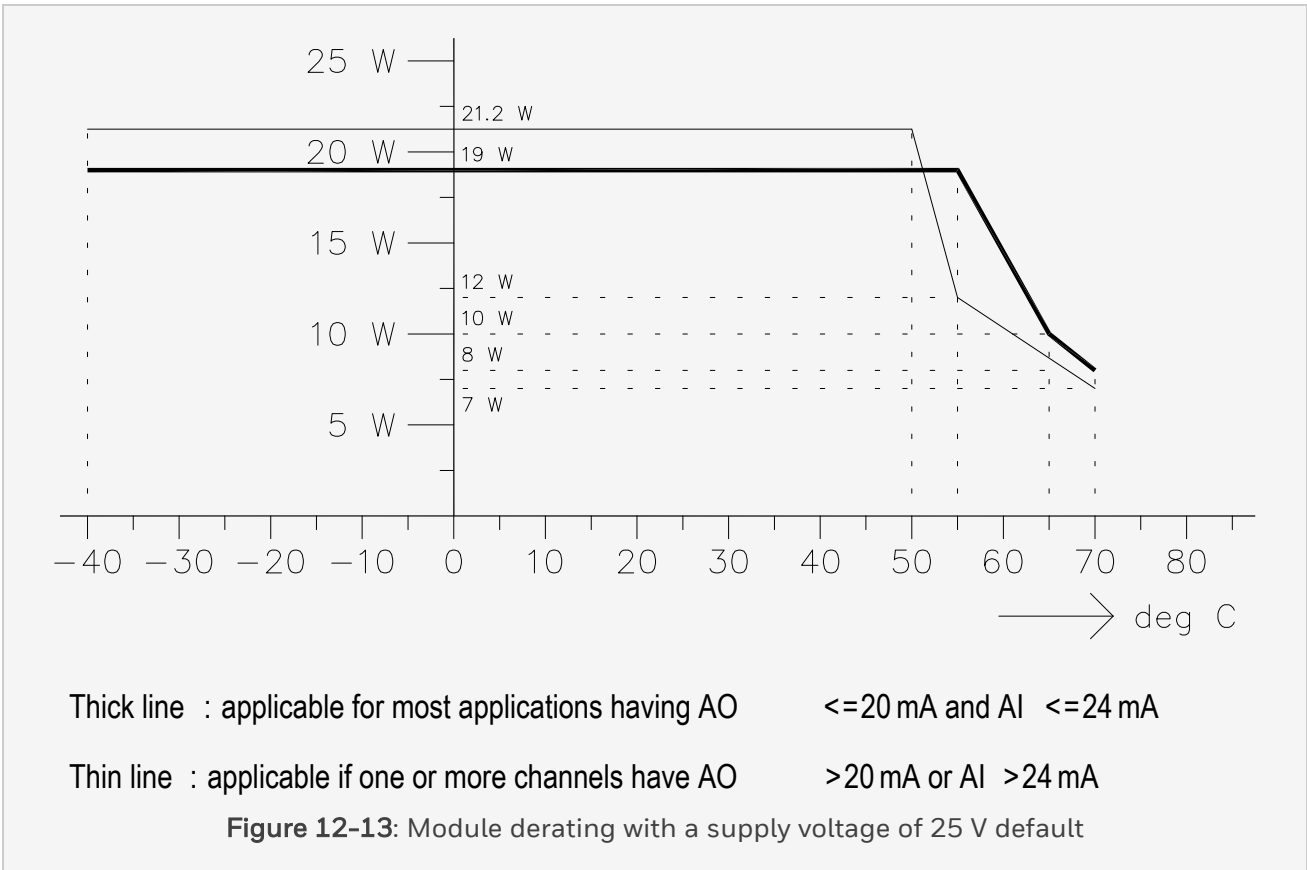

The below table shows a calculation example using the table for a 25 V supply voltage. The column “Number of configured channels” is filled in for the actual situation. Totals per channel type are calculated in the column “Dissipation contribution”.

The “Total internal power dissipation” is calculated at the bottom. Using the applicable line in the below figure the maximum outside module temperature is deduced.

In this example the maximum outside module temperature allowed is 70°C, with the High temperature shutdown of the module set at 90°C.

**Note:**

The maximum outside temperature limit can be improved with forced airflow.

*Table 3. Example: dissipation calculation - supply voltage 25 V*

Dissipation contributor (P)	Max. dissipation per channel [W]	Number of configured channels	Dissipation [W]
Logic			5.5
DI-LM; field impedance $\geq 5$ KOhm	0.01	10	0.1
DI; closed contact; 3.5 mA	0.085		
AI; < 24 mA; Current limited by field	0.05	10	1.5
AI; > 24 mA; Current limited by RUSIO <sup>1</sup>	0.49		
DO; <0.3 A	0.115	10	1.15
DO; <0.5 A	0.305		
AO; 500 Ohm field impedance; < 23 mA	0.225		
AO; 250 Ohm field impedance; < 23 mA	0.335	2	0.67
AO; < 250 Ohm; < 23 mA	0.47		
AO; < 250 Ohm; < 20 mA	0.42		
Total Power Dissipation (TPD) [W]			7.92
Max. outside module temperature [°C]			+70
<p>1. Analogue input currents above 24 mA should be avoided. Field devices for the analogue input should be configured to drive currents below 24 mA, e.g. 3.5 mA for sensor fault conditions to minimize the Safety Manager universal IO internal power dissipation. The thin-line derating curve needs to be taken when using currents above 24 mA.</p>			

12 Universal Safety IO

12.1 RUSIO-3224

12.1.5.3 Temperature derating curves (31.2V supply voltage)

The below figure shows the maximum outside module temperature versus the internal power dissipation. It shows the derating curves for 31.2V supply voltage.

An example calculation for this supply voltage is given in the below table.

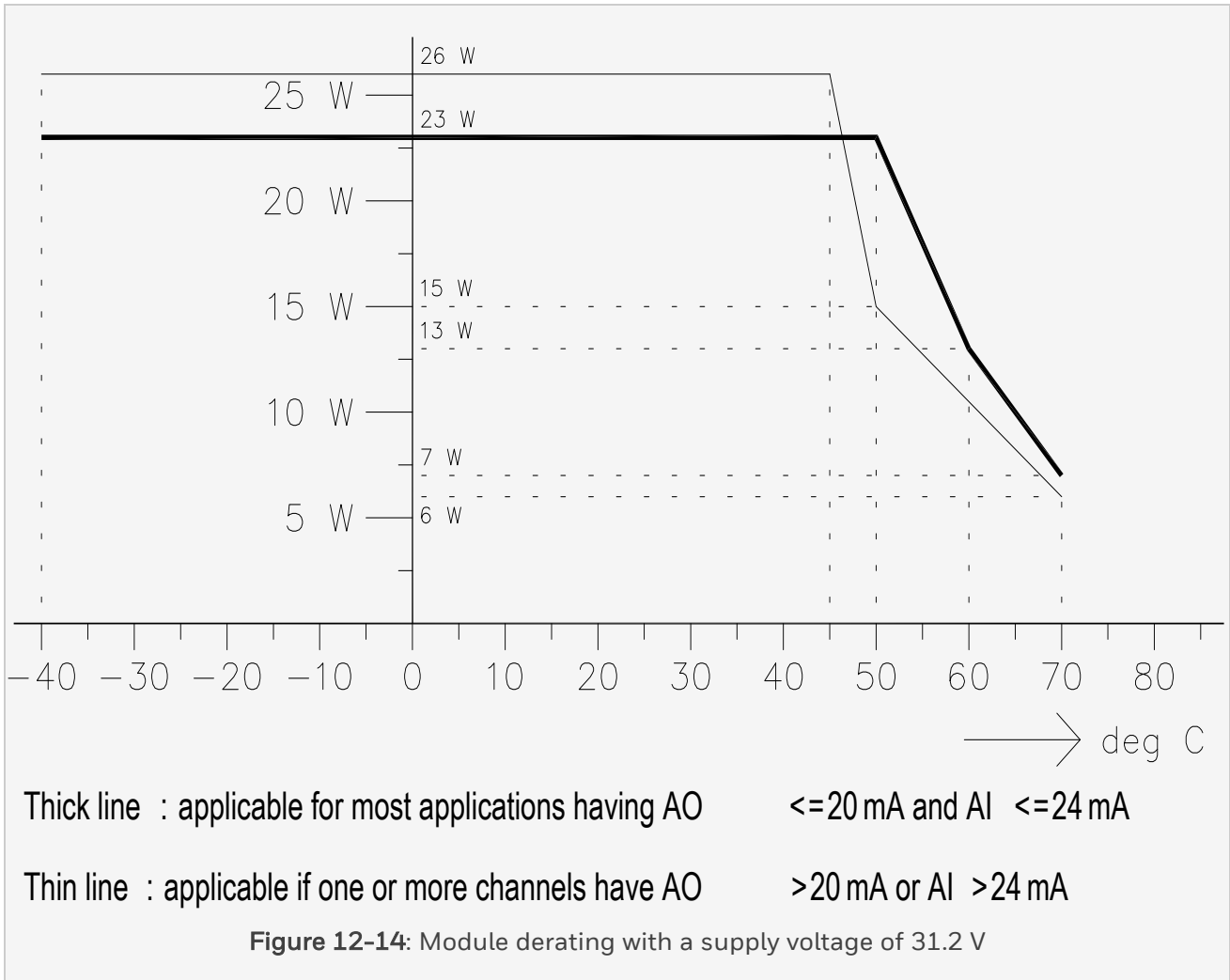

The below table shows a calculation example using the table for a 31.2 V supply voltage. The column “Number of configured channels” is filled in for the actual situation. Totals per channel type are calculated in the column “Dissipation contribution”.

The “Total internal power dissipation” is calculated at the bottom. Using the applicable line in "Module derating with a supply voltage of 31.2 V" above the maximum outside module temperature is deduced.

In this example the maximum outside module temperature allowed is 65°C, with the High temperature shutdown of the module set at 90°C.

**Note:**

The maximum outside temperature limit can be improved with forced airflow.

12 Universal Safety IO

12.1 RUSIO-3224

**Table 4. Example: dissipation calculation - supply voltage 31.2 V**

Dissipation contributor (P)	Max. dissipation per channel [W]	Number of configured channels	Dissipation [W]
Logic			5.5
DI-LM; field impedance $\geq 5$ KOhm	0.01	2	0.02
DI; closed contact; 3.5 mA	0.085		
AI; < 24 mA; Current limited by field	0.05	21	1.05
AI; > 24 mA; Current limited by RUSIO <sup>1</sup>	0.64		
DO; <0.3 A	0.115		
DO; <0.5 A	0.305	9	2.75
AO; 500 Ohm field impedance; < 23 mA	0.345		
AO; 250 Ohm field impedance; < 23 mA	0.48		
AO; < 250 Ohm; < 23 mA	0.61		
AO; < 250 Ohm; < 20 mA	0.545		
Total Power Dissipation (TPD) [W]			9.32
Max. outside module temperature [°C]			65
<p>1. Analogue input currents above 24 mA should be avoided. Field devices for the analogue input should be configured to drive currents below 24 mA, e.g. 3.5 mA for sensor fault conditions to minimize the Safety Manager universal IO internal power dissipation. The thin-line derating curve needs to be taken when using currents above 24 mA.</p>			

### 12.1.6 Power supply ripple (24 V DC supply voltage)

The Safety Manager with Universal IO can tolerate a distortion or ripple on the 24 V DC power supply as defined in the following graph.

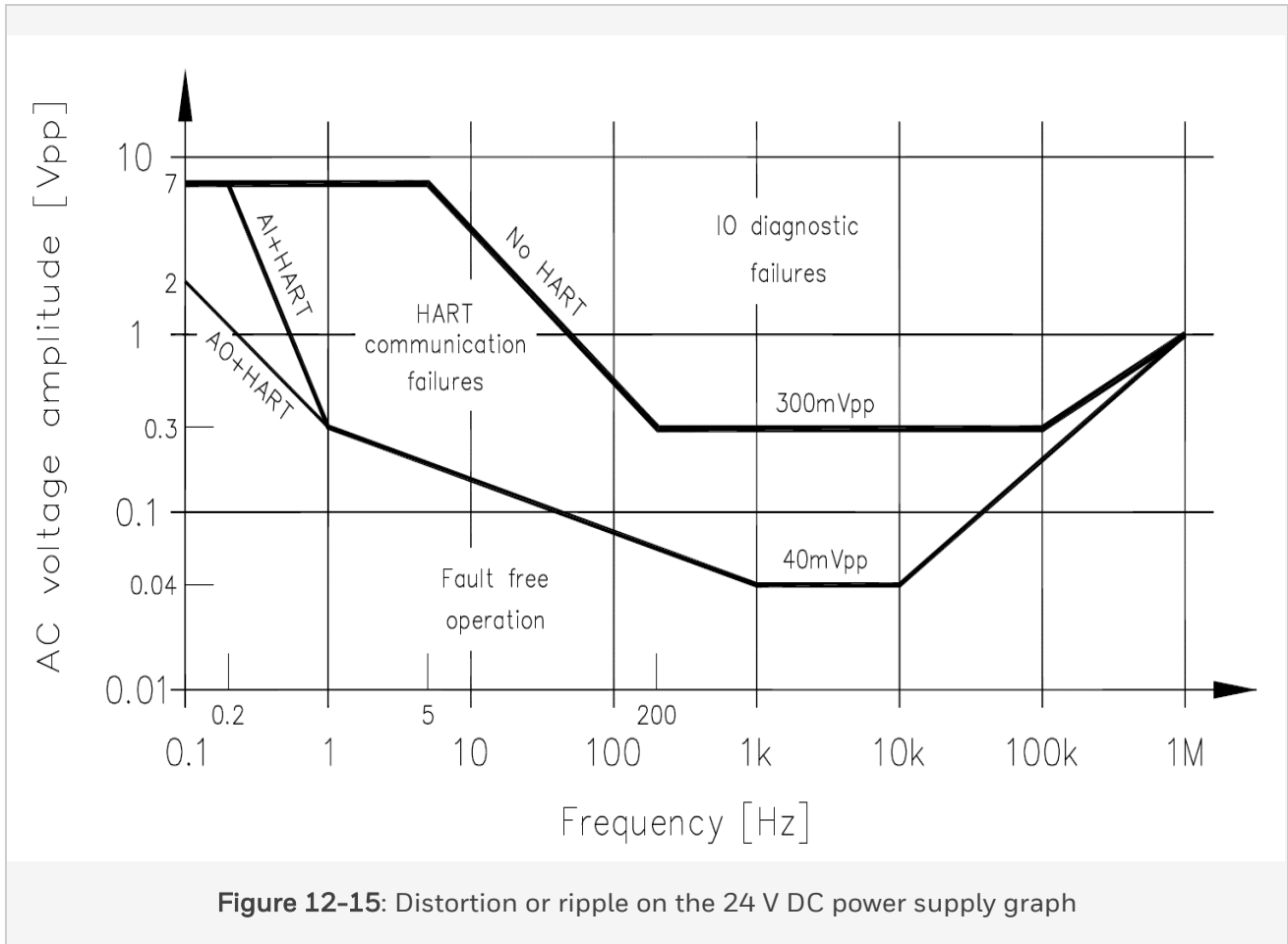

Figure 12-15: Distortion or ripple on the 24 V DC power supply graph

### 12.1.7 Module handling replacement

This sub section describes the procedures for removal and installation of a RUSIO-3224 module. See the below figure for relevant details.

## 12 Universal Safety IO

### 12.1 RUSIO-3224

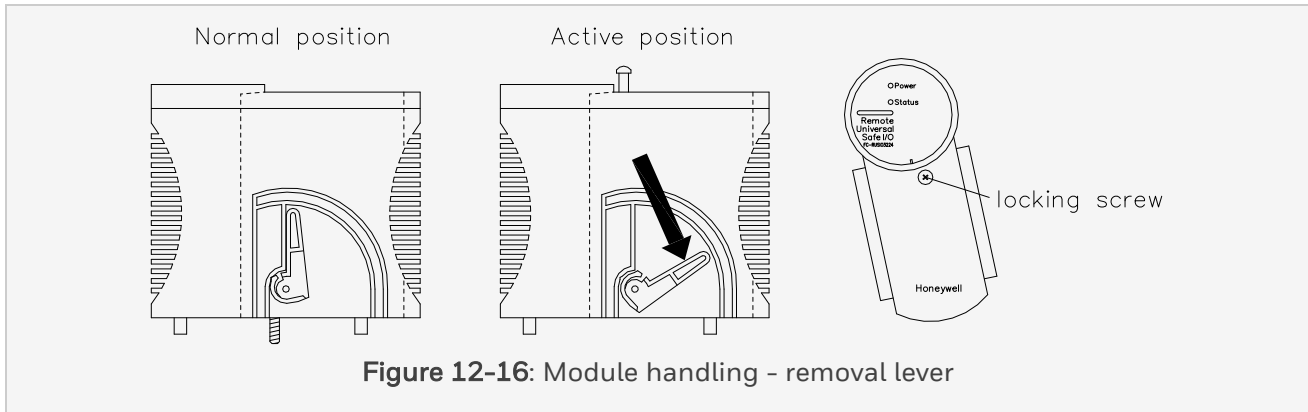

**Figure 12-16:** Module handling - removal lever

#### 12.1.7.1 Removal of a RUSIO-3224 module

Do these steps in the order given to remove the subject RUSIO-3224 module:

1. On the IOTA, set the applicable switch (POWER 1 or POWER 2) to OFF. The Power LED (green) must go off.
2. Completely loosen the locking screw.
3. Press both (removal) levers at the sides of the module down *at the same time*. See Active Position in the "Module handling - removal lever" above.
4. Remove the module from the IOTA.
5. Put the (removal) levers back in the upright (normal) position.

#### 12.1.7.2 Installation of a RUSIO-3224 module

Do these steps in the order given to install the subject RUSIO-3224 module:

1. On the IOTA, make sure that the applicable switch (POWER 1 or POWER 2) is set to OFF.
2. On the module to be installed, make sure that the (removal) levers are in the upright (normal) position.
3. Hold the module in the correct position on the IOTA and carefully push it down on the corresponding connectors.
4. Tighten the locking screw.

5. On the IOTA, set the applicable switch (POWER 1 or POWER 2) to ON. The Power LED (green) must go on.

## 12 Universal Safety IO

### 12.1 RUSIO-3224

---

#### 12.1.8 Technical data

The RUSIO-3224 module has the following specifications:

General	Type number:	FC-RUSIO-3224
	Operating temperature:	
	<ul style="list-style-type: none"> <li>outside module temperature:</li> </ul>	-40°C ... +70°C (-40°F ... +158°F)
	<ul style="list-style-type: none"> <li>inside module temperature:</li> </ul>	-40°C ... +90°C (-40°F ... +194°F)
	Storage temperature:	-40°C ... +85°C (-40°F ... +185°F)
	Relative humidity:	10 ... 95% (non condensing)
	Pollution:	Pollution degree 2 or better
	Approvals:	CE, UL, TÜV
Power	Supply voltage:	24 V DC -15% ... +30%
	Supply current:	max 300mA (without field load)
IO	Number of channels:	32
	Channel type:	Universal safe (software configurable)
	<ul style="list-style-type: none"> <li>Digital in</li> </ul>	max. 32 (with or without line-monitoring)
	<ul style="list-style-type: none"> <li>ESD in</li> </ul>	max. 1 (with line-monitoring)
	<ul style="list-style-type: none"> <li>Analog in</li> </ul>	max. 32 (with or without line-monitoring)
	<ul style="list-style-type: none"> <li>Digital out</li> </ul>	max. 32 (with or without line-monitoring) max. combined load: 9 A
	<ul style="list-style-type: none"> <li>Analog out</li> </ul>	max. 16 (with or without open loop detection)
	Maximum field capacitance	100 nF (for AI / DI / AO channels) 1 µF (for DO channels)

12 Universal Safety IO

12.1 RUSIO-3224

---

Physical Data	Dimensions (H x W x D):	145 x 165.1 x 72.4 mm
		5.7 x 6.5 x 2.85 in
	Weight:	0.66 kg
		1.45 lbs