

# 6 Options

## 6.1 Options which can be integrated into the electronics box

One or two option boards, listed in Table 6.1, can be inserted in the electronics box using the LBA option (local bus adapter).

Before installing option boards in the electronics box, the LBA (local Bus Adapter) has to be inserted.

### Install the LBA bus expansion:

- ◆ Remove the CU (lefthand slot in the electronics box) using the handles after first removing the connecting cable to the PMU and both retaining screws.
- ◆ Insert the LBA bus expansion in the electronics box (position, refer to the diagram) so that it snaps into place.
- ◆ Re-insert the CU into the lefthand slot, screw the retaining screws on the handles tight, and insert the connecting cable to the PMU.
- ◆ Insert the option board in slot 2 (right) or slot 3 (center) of the electronics box, and screw into place. Each option board may only be inserted in the electronics box. If only one option is used, it must always be inserted at slot 2 (right).

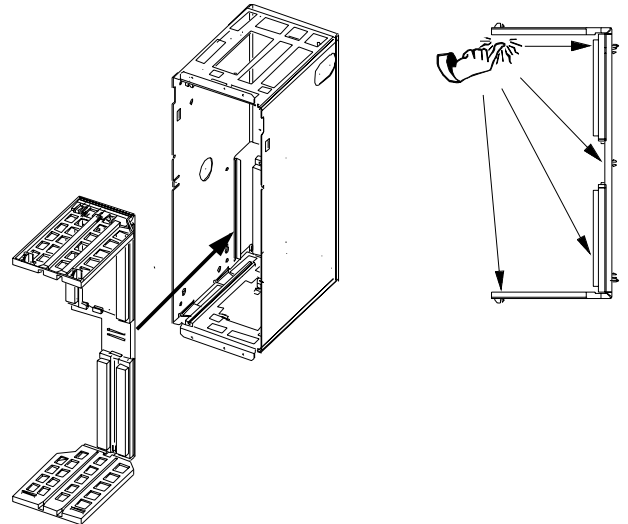

Fig. 6.1 Installing the Local Bus Adapter

Slots in the electronics box		Boards
Left	Slot 1 (CU)	CU
Center	Slot 3 (options)	CB1 / SCB1 / SCB2
Right	Slots 2 (options)	CB1 / SCB1 / SCB2 / TSY / TB
<b>NOTES</b>		
<ul style="list-style-type: none"> <li>◆ Only one of each option board type may inserted in the electronics box.</li> <li>◆ TB (technology boards, e.g. T300) must always be inserted at slot 2. When a TB board is used, a TSY board may not be inserted.</li> <li>◆ If only one option board is used it must always be inserted at slot 2.</li> </ul>		

Table 6.1 Possible arrangements of boards in the electronics box

The options are supplied with the option description.

Designation	Description	Order No.	
		Board description	
LBA	Local bus adapter for the electronics box. This is required for installing T300, CB1, TSY, SCB1 and SCB2	Board description	6SE7090-0XX84-4HA0 6SE7087-6CX84-4HA0
T300	Technology board for controlling technological processes	Board description	6SE7090-0XX84-0AH0 6SE7087-6CX84-0AH0
SCB1	Serial communications board with fiber-optic cable for serial I/O system and peer-to-peer connection	Board description	6SE7090-0XX84-0BC0 6SE7087-6CX84-0BC0
SCB2	Serial communications board for peer-to-peer connection and USS protocol via RS485	Board description	6SE7090-0XX84-0BD0 6SE7087-6CX84-0BD0
	Use of the serial interface with USS protocol	Application description	6SE7087-6CX87-4KB0
CB1	Communications board with interface for SINEC- L2-DP, (Profibus)	Board description	6SE7090-0XX84-0AK0 6SE7087-6CX84-0AK0
	Use of the PROFIBUS DP interface	Application description	6SE7087-6CX87-0AK0
SSB	Safety OFF (Safe Stop Board) Option K80	Description	6SE7080-0AX87-1JB0

Table 6.2 Option boards and bus adapter

If the converter is supplied through an external main contactor, the option board in the electronics box must be supplied from an external power supply, according to Table 6.3.

These values are required in addition to the current drawn by the basic converter (see section "Technical Data").

Board	Current drain (mA)
CB1	190
SCB1	50
SCB2	150
TSY w/out tacho	150
T300 w/out tacho	620
Standard tacho Type: 1XP 8001-1	$I_0$ 95 (190 at 6000 RPM)

Table 6.3 Current drain of the option boards