

SPAJ 142 C

Overcurrent and earth-fault relay

User's manual and Technical description

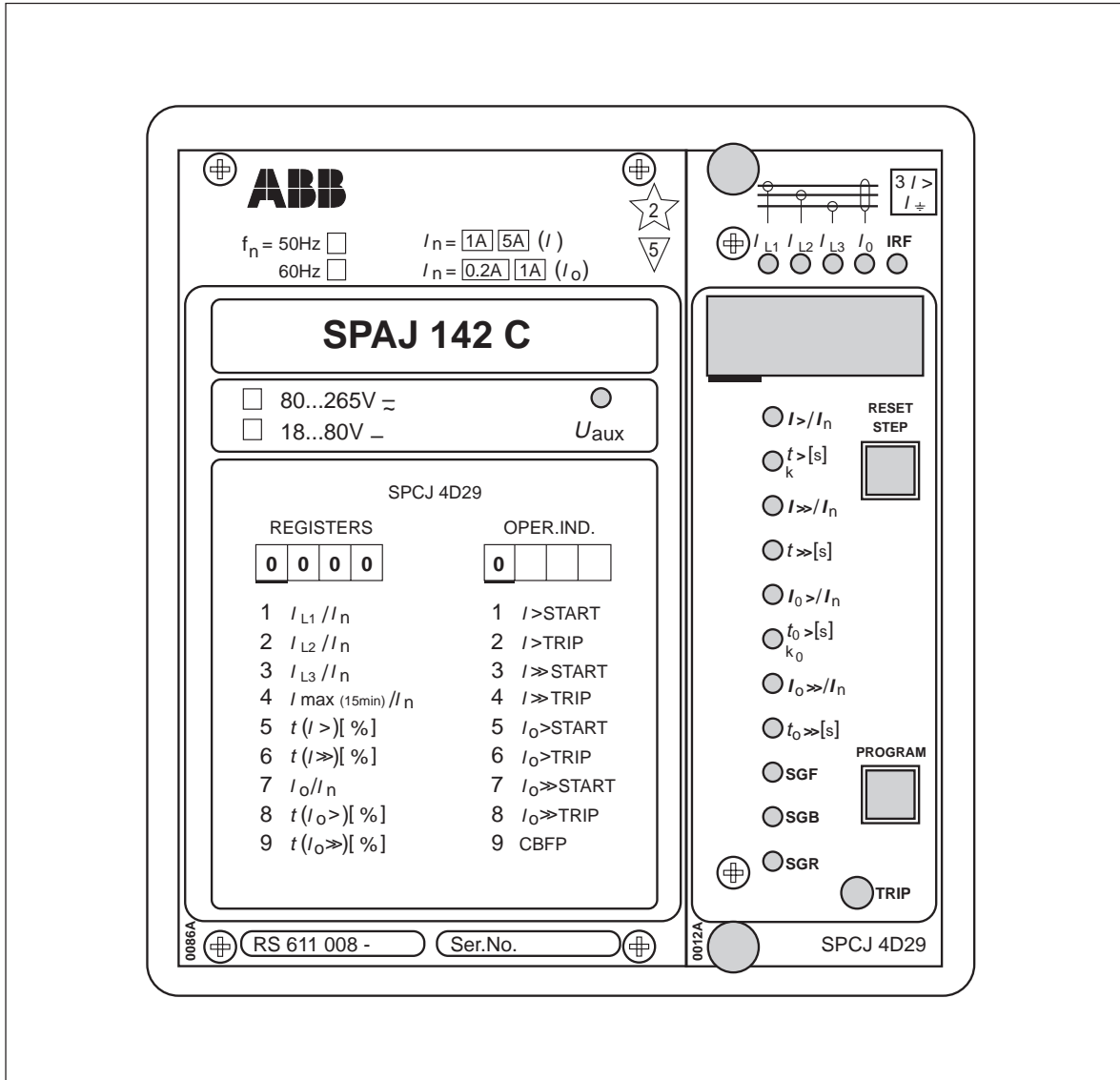

SPAJ 142 C

Combined overcurrent and earth-fault relay

Data subject to change without notice

Contents	Characteristics	2
	Application	2
	Description of operation	3
	Connection diagram	4
	Connections	6
	Control signals between the modules	7
	Signal abbreviations used	7
	Operation indicators	8
	Power supply and output relay module	9
	Technical data (<i>modified 2002-04</i>)	10
	Maintenance and repairs	13
	Spare parts	13
	Dimensions and instructions for mounting	14
	Ordering information	15

The complete manual for the relay SPAJ 142 C contains the following partial manuals:

General relay description	1MRS 750873-MUM EN
General characteristics of D-type relay modules	1MRS 750066-MUM EN
Combined overcurrent and earth-fault module SPCJ 4D29	1MRS 750119-MUM EN

Characteristics	Three-phase low-set overcurrent unit with definite time or inverse time (IDMT) characteristic.	Fully selectable output relay configuration.
	Three-phase high-set overcurrent unit with instantaneous or definite time function.	Extensive data communication facilities over serial port.
	Low-set non-directional earth-fault protection with definite time or inverse time (IDMT) characteristic.	Outstanding design flexibility for easy selection of appropriate operational scheme for various applications.
	High-set non-directional earth-fault protection with instantaneous or definite time function.	Numerical display of setting values, current measured values, memorized fault values etc.
	Built-in breaker failure protection scheme.	Continuous selfsupervision with autodiagnosis for internal faults.

Application	The combined overcurrent and earth-fault relay SPAJ 142 C is intended to be used for the selective short-circuit and earth-fault protection of radial feeders in solidly earthed, resistance earthed or impedance earthed power systems. The integrated protective relay comprises both an overcurrent unit and an earth-fault unit with	highly flexible tripping and signalling facilities. The feeder protection can be used in applications requiring a single-, two- or three-phase overcurrent protection and a non-directional earth-fault protection. The overcurrent and earth-fault relay also comprises a circuit breaker failure protection.
--------------------	--	--

Description of operation

The combined overcurrent and earth-fault relay is a secondary relay device to be connected to the current transformers of the feeder to be protected. The three-phase overcurrent unit and the non-directional earth-fault unit continuously measure the phase currents and the neutral current of the protected feeder. In fault situations these units initiate external auto-reclose functions or trip the circuit-breaker, depending on the selected protective scheme.

When a phase current exceeds the starting value of the low-set overcurrent unit, the unit starts, simultaneously starting the corresponding timing circuit. When the set operating time has elapsed, a circuit-breaker tripping command is delivered. Correspondingly, the high-set stage of the overcurrent unit starts when its starting value is exceeded, starting its timing circuit and performing a tripping when the set time has elapsed.

The low-set stage of the non-directional earth-fault unit operates in the same way. Depending on the protective scheme it either signals, performs a tripping or initiates a function of an external auto-reclose relay.

The low-set stage of the overcurrent unit and the low-set stage of the earth-fault unit may be given definite time or inverse definite minimum time (IDMT) characteristics. When the IDMT characteristic is to be chosen six curve types are available in the relay. Four of the curves types comply with BS 142 and IEC 60255 and are named normal inverse, very inverse, extremely inverse and long-time inverse. The two additional curves are named the RI curve and the RXIDG curve.

By appropriate programming of the tripping relay matrix, the starting signals of the overcurrent and non-directional earth-fault modules are received as contact functions. This contact information is used e.g. for the blocking of co-operating protective relays located upstreams.

The relay comprises one external logic control input, which is actuated by a control signal of the auxiliary voltage level. The influence on the relay by the control input is determined by programming switches in the measuring module. The control input can be used either for blocking one or more of the protective stages, for resetting a latched output relay in the manual reset mode or for selecting a new group of relay settings by remote control.

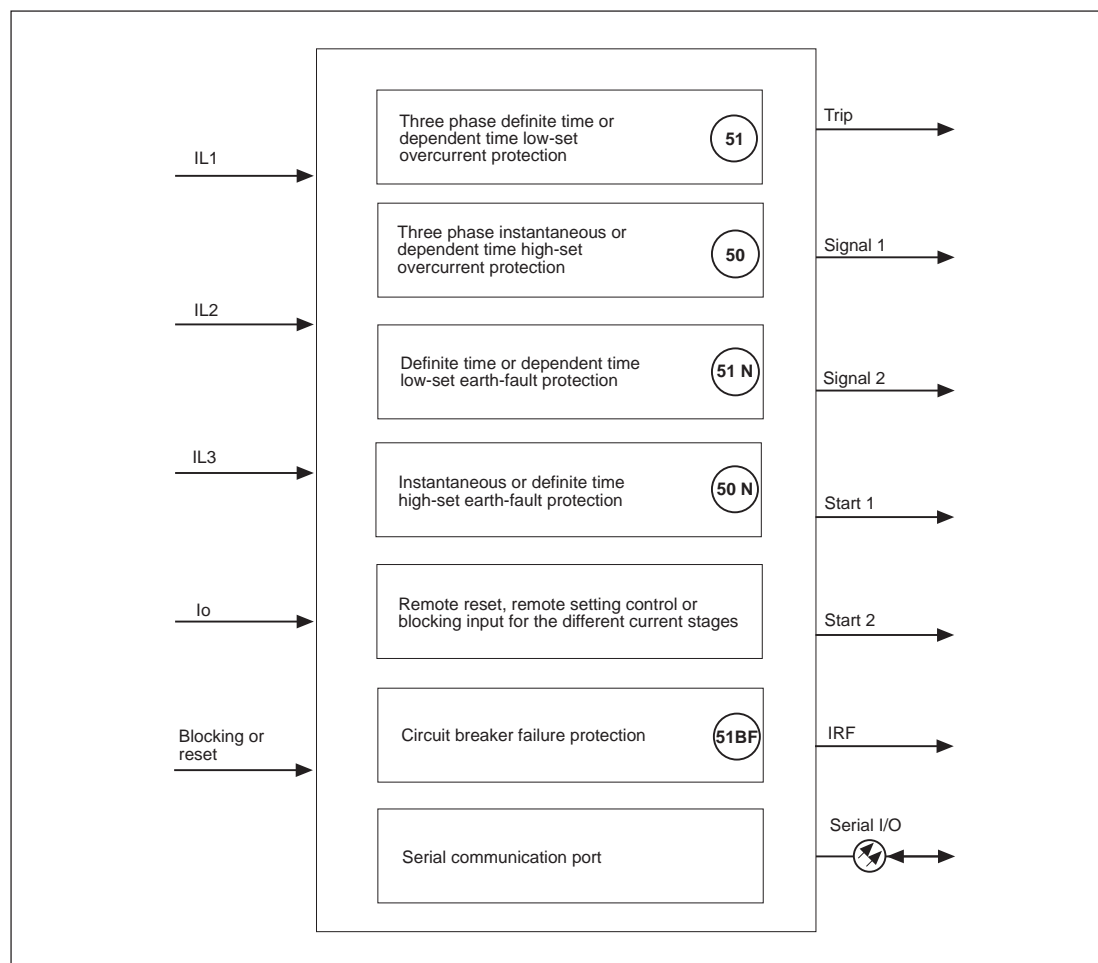

Fig. 1. Protective functions of the overcurrent and earth-fault relay SPAJ 142 C.

Connection diagram

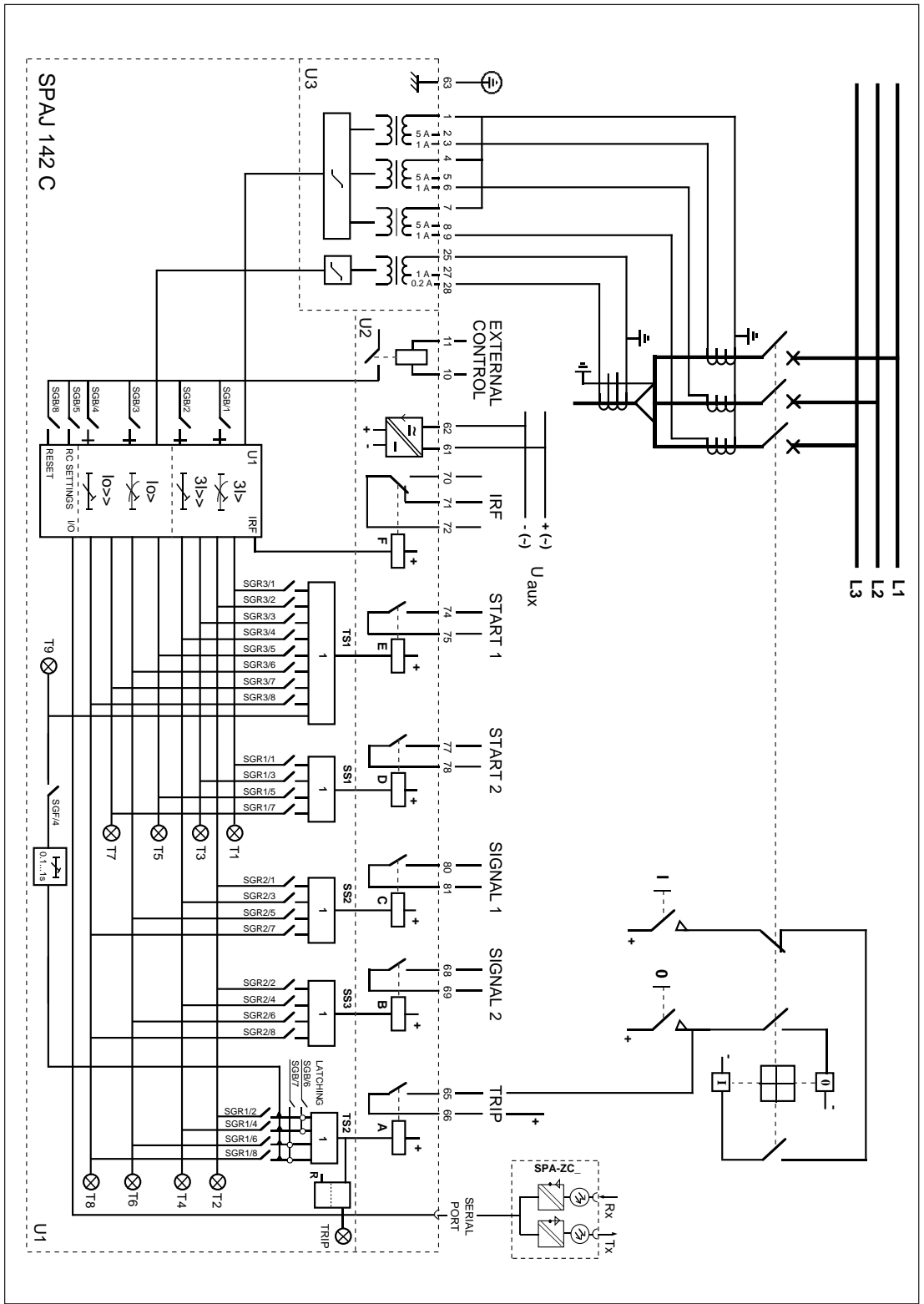

Fig. 2. Connection diagram for the combined overcurrent and earth-fault relay SPAJ 142 C with all the relay matrix switchgroups shown.

U_{aux}	Auxiliary voltage
A, B, C, D, E, F	Output relays
IRF	Self-supervision
SGR	Switchgroups for the configuration of trippings and signalings
SGB	Switchgroup for the configuration of the blocking or control signal
TRIP	Trip output relay
SIGNAL 1	Signal on overcurrent trip
SIGNAL 2	Signal on earth-fault trip
START 1	Starting or auxiliary trip signal as selected with switchgroup SGR3
START 2	Starting of overcurrent low-set stage I>
U1	Three-phase overcurrent and non-directional earth-fault module SPCJ 4D29
U3	Input module SPTE 4E2
U2	Power supply and output relay module SPTU 240 R1 or SPTU 48 R1
T1...T8	Starting and tripping indications
SERIAL PORT	Serial communication interface
SPA-ZC_	Bus connection module
Rx/Tx	Receiver bus terminal (Rx) and transmitter bus terminal (Tx) of the bus connection module

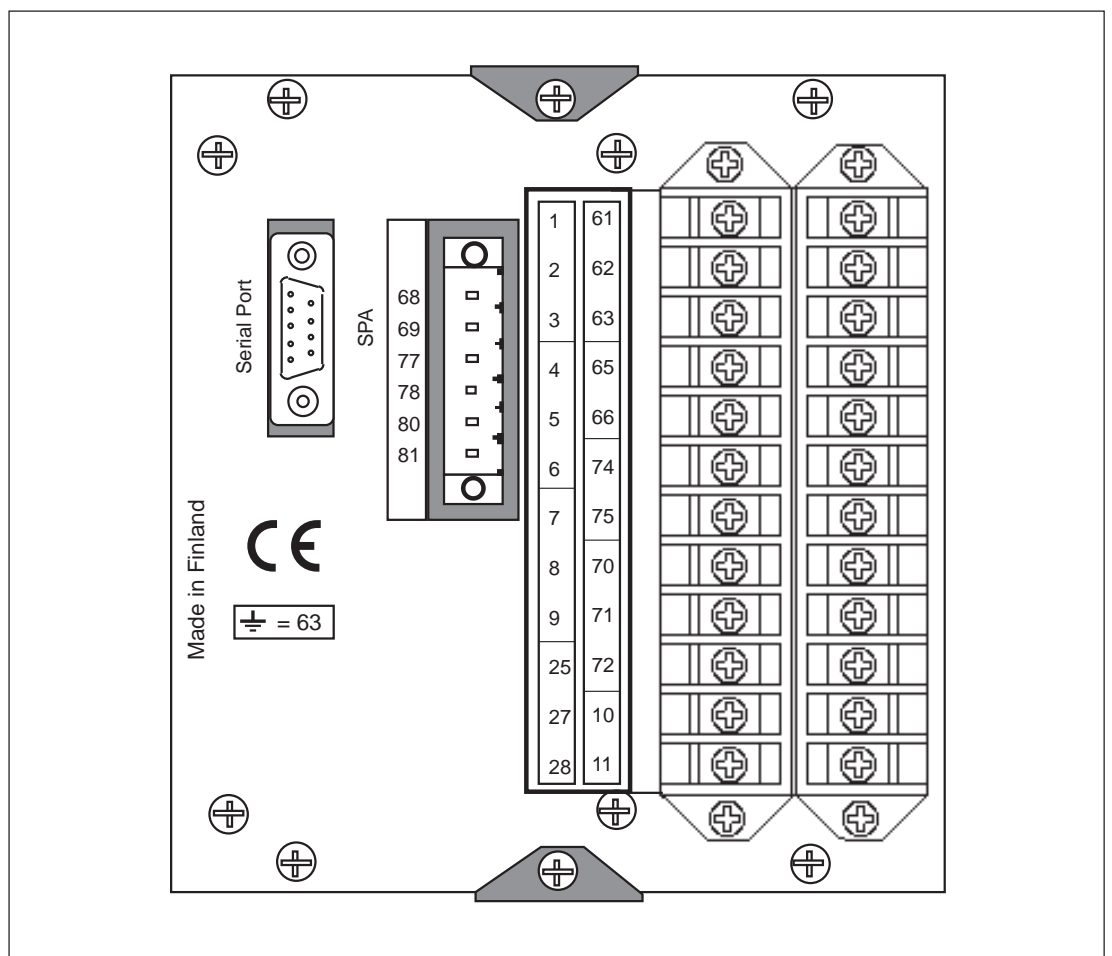

Fig. 3. Rear view of relay SPAJ 142 C.

Connections

The three phase-currents of the overcurrent protection are connected to terminals 1-2, 4-5 and 7-8, when the rated current of the secondary circuits is $I_n = 5 \text{ A}$. When using current transformers with a rated current of 1 A, terminals 1-3, 4-6 and 7-9 are used. The overcurrent protection may also be used in single-phase or two-phase applications, in which case inputs not to be used are left unconnected. In single-phase applications, however, wiring the phase current through two current inputs in series may increase the operating speed of the relay, particularly for instantaneous operations.

The neutral current of the earth-fault protection is connected to terminals 25-27 when the rated current is 1 A and to terminals 25-28 when the rated current is 0.2 A.

The control input 10-11 can be used in three different ways, as the control input of an external blocking signal for the measuring modules, as the control input for unlatching the trip relay, or as the control input for the remote control of settings. The function is selected by means of switches 1...8 of switchgroup SGB in the main menu of the measuring relay module.

The auxiliary supply voltage of the relay is connected to the terminals 61-62. At d.c. auxiliary supply voltage the positive lead is connected to terminal 61. The level of the voltage to be applied to the terminals is determined by the type of power supply and output relay module inserted in the protection. For further details see the description of the power supply module. The auxiliary voltage range of the relay has been marked on the front panel.

Output relay A provides the CB tripping commands so that the CB operates once the operating time of the low-set or high-set stage of the overcurrent or non-directional earth-fault module has elapsed. The stages to perform a tripping are selected with switches 2,4,6 and 8 of switchgroup SGR1. On delivery from factory all stages are selected to perform tripping. A latching function of the output relay A can be selected by means of switches SGB 6 and 7 for overcurrent and earth-fault trippings.

The trip alarm signals from the measuring modules are obtained through output relays B and C. The signals to be forwarded to the output relays B and C are selected with switches 1...8 of switchgroup SGR2 of the measuring module. The switch matrixes for configuration of

the control signals of the output relays B and C identical. Normally the output relays B and C are given such a configuration that low-set and high-set overcurrent trip alarm signal is obtained over relay C and the corresponding alarm signal for the earth-fault trips via output relay B. This is also the default setting on delivery.

The starting signals from the protective stages of the relay are received through output relay D. The signals to be forwarded to the output relay D are selected by means of switches 1, 3, 5 and 7 of switchgroup SGR1 which is found in the main menu of the measuring module. The starting signals of the low-set and high-set stage of the overcurrent unit are selected with switches 1 and 3, whereas switches 5 and 7 convey the corresponding signals of the non-directional earth-fault unit.

Output relay E, terminals 74-75, is a heavy duty output relay capable of controlling a circuit breaker, like the main trip relay A. Relay E is used mainly for bringing out any starting or time delayed signal for starting of auto-reclosures, for signalling or counting purposes or for auxiliary trip. Output relay E is also used as a tripping output for the circuit breaker failure protection, CBFP when the CBFP function is used. In this case the trip signal can be used either to control a circuit breaker upstreams or to control a second trip coil on the main circuit breaker to give a higher redundancy to the breaker operation.

Output relay F, terminals 70-71-72, operates as the output relay of the self-supervision system of the relay. The relay operates on the closed-circuit principle so that in normal service conditions the contact gap 70-72 is closed. If a fault is detected by the self-supervision system, or if there is a failure in the auxiliary supply, the output relay drops off providing an alarm signal by closing the NO contact 71-72.

The relay is interfaced with a data transmission bus through a 9-pole, D-type subminiature connector located at the rear panel of the relay. By means of bus connection modules SPA-ZC 17 or SPA-ZC 21 the overcurrent and earth-fault relay can be linked to the fibre-optic bus. The terminals of the fibre-optic cables are connected to the counter terminals Rx and Tx of the bus connection module. The fibre-optic cables are linked from one protection to another and to the substation level communication, for instance type SRIO 1000M.

Control signals between the modules

The figure below schematically illustrates how the starting, tripping, control and blocking sig-

nals can be programmed to obtain the required function of the protection.

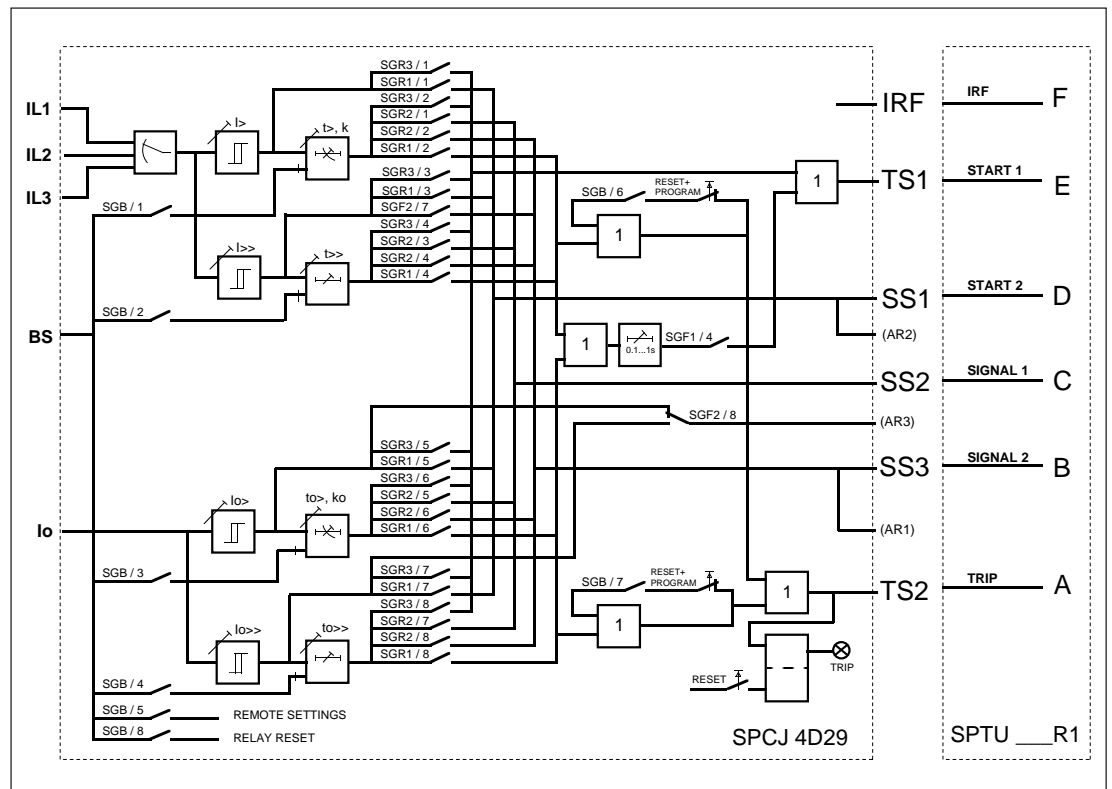

Fig. 4. Control signals between the modules of the overcurrent and earth-fault relay SPAJ 142 C.

The functions of the blocking and starting signals are selected with the switches of switch-groups SGF, SGB and SGR. The checksums of the switchgroups, are found in the setting menu

of the measuring relay module. The functions of the different switches are explained in the user's manual of the measuring module SPCJ 4D29.

Signal abbreviations used

I_{L1}, I_{L2}, I_{L3}	Phase currents to be measured
I_0	Neutral current
BS	Blocking or control Signal
SS1	Starting Signal 1
SS2	Starting Signal 2
SS3	Starting Signal 3
TS1	Tripping Signal 1
TS2	Tripping Signal 2
BS	Blocking Signal
AR1...3	Auto-Reclose starting signals (not in use in SPAJ 142 C)
IRF	Internal Relay Fault signal
SGF	Switch Group for Functions
SGB	Switch Group for Blockings
SGR	Switch Group for Relay configuration
IRF	Internal Relay Fault
Rx/Tx	Receiver/Transmitter channel

Operation indicators

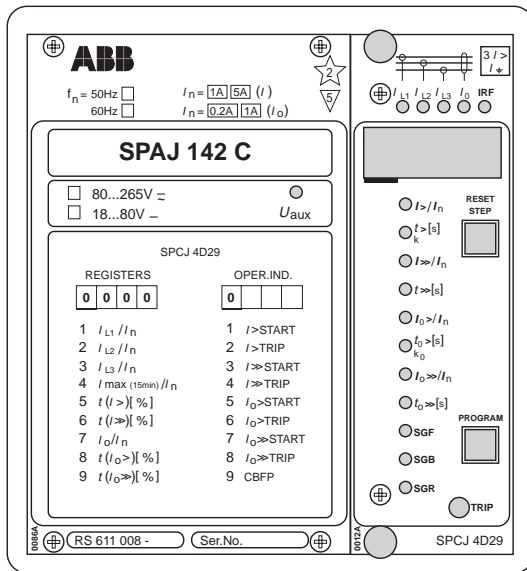

A) The operation indicator TRIP is switched on when one of the protective stages operate. When the protective stage resets, the red indicator remains alight.

B) If the display is dark when one of the protective stages $I>$, $I>>$, $I_0>$ or $I_0>>$ call for a tripping, the faulty phase or the neutral path is indicated with a yellow LED. If, for instance, the TRIP indicator glows red, and the indicators I_{L1} and I_{L2} at the same time are illuminated, overcurrent has occurred on phase L1 and L2.

C) Besides being a code number at data presentation, the leftmost red digit or the display serves as a visual function indicator. A function indicator is recognized by the fact that the red digit alone is switched on. The following table named OPERATION IND. is a key to the function code numbers used.

Indication	Explanation
1	$I>$ START = The low-set stage $I>$ of the overcurrent unit has started
2	$I>$ TRIP = The low-set stage $I>$ of the overcurrent unit has tripped
3	$I>>$ START = The high-set stage $I>>$ of the overcurrent unit has started
4	$I>>$ TRIP = The high-set stage $I>>$ of the overcurrent unit has tripped
5	$I_0>$ START = The low-set stage $I_0>$ of the earth-fault unit has started
6	$I_0>$ TRIP = The low-set stage $I_0>$ of the earth-fault unit has tripped
7	$I_0>>$ START = The high-set stage $I_0>>$ of the earth-fault unit has started
8	$I_0>>$ TRIP = The high-set stage $I_0>>$ of the earth-fault unit has tripped
9	CBFP = Circuit Breaker Failure Protection has operated

D) The TRIP indications persist when the protective stage returns to normal. The indicator is reset by pushing the RESET/STEP push-button.

Further, the indicators may be reset via the external control input 10-11 by switching a control voltage to the input, provided that the microswitch SGB/8 is in position 1.

The basic protective relay functions are not depending on the state of the operation indicators, reset or non-reset. The relay is permanently operative.

If a protective stage starts, but no tripping occurs because the energizing quantity goes below the starting level before the delay circuit times out, the starting indicators are normally automatically switched off. However, by means of the switches SGF2/1...4 the starting indications may be made persistent which means that they are to be reset by pushing the RESET/STEP push-button.

The persistent indications are obtained through the following programming.

Switch SGF2/1 = 1

Starting indication on $I>$ persistent

Switch SGF2/2 = 1

Starting indication on $I>>$ persistent

Switch SGF2/3 = 1

Starting indication on $I_0>$ persistent

Switch SGF2/4 = 1

Starting indication on $I_0>>$ persistent

On delivery from the factory the switches SGF2/1...4 have the preset configuration 0.

E) Shortly after the internal self-supervision system has detected a permanent relay fault the red IRF indicator is switched on and the output relay of the self-supervision system operates. Further, in most fault situations a autodiagnostic fault code is shown in the display. The fault code is composed of a red figure 1 and a green code number which indicates what may be the fault type. The fault code can not be reset as long as the fault persists. When a fault code appears on the display, the code number should be recorded on a piece of paper and given to the authorized repair shop when overhaul is ordered.

Power supply and output relay module

To be able to operate the relay needs a secured auxiliary voltage supply. The power supply module forms the voltages required by the measuring relay module and the auxiliary relays. The withdrawable power supply and output relay module is located behind the system front panel, which is fixed by means of form cross-slotted screws. The power supply and output relay module contains the power supply unit, all output relays, the control circuits of the output relays and the electronic circuitry of the external control inputs.

The power supply and output relay module can be withdrawn after removing the system front

panel. The primary side of the power supply module is protected with a fuse, F1, located on the PCB of the module. The fuse size is 1 A (slow).

The power supply unit is a transformer connected, i.e. galvanically isolated primary and secondary side, flyback-type dc/dc converter. It forms the dc secondary voltages required by the measuring relay module; that is +24 V, ± 12 V and +8 V. The output voltages ± 12 V and +24 V are stabilized in the power supply module, while the +5 V logic voltage required by the measuring relay module is formed by the stabilizer of the relay module.

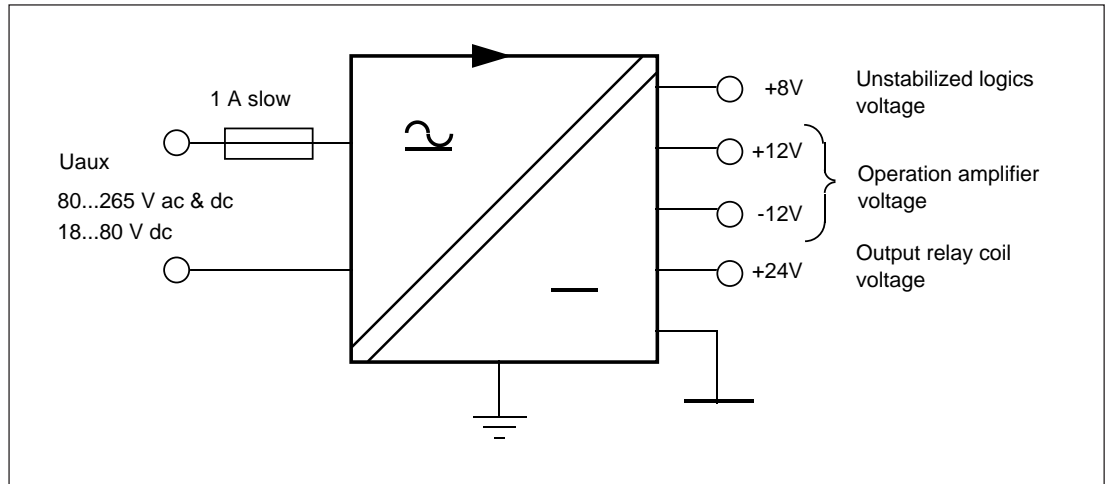

Fig. 5. Voltage levels of the power supply module.

A green LED indicator U_{aux} on the system front panel is illuminated when the power supply module is in operation. The supervision of the voltages supplying the electronics is placed in the measuring module. If a secondary voltage deviates from its rated value by more than 25 %, a selfsupervision alarm will be established. An alarm is also received when the power supply module is withdrawn from the relay case, or when the auxiliary power supply to the relay is interrupted.

There are two versions of power supply and output relay modules available. For both types, the secondary sides and the relay configurations are identical, but the input voltage ranges differ.

Insulation test voltage between the primary and secondary side and the protective earth
2 kV, 50 Hz, 1 min

Rated power P_n 5 W

Voltage ranges of the power supply modules:
- SPTU 240 R1 $U_{aux} = 80...265$ V dc/ac
- SPTU 48 R1 $U_{aux} = 18...80$ V dc
(on request)

The SPTU 240 R1 module can be used with both ac and dc voltages. SPTU 48 R1 is designed for dc supply only. The system front panel of the relay indicates the auxiliary voltage range of the power supply module of the relay assembly.

Technical data
(modified 2002-04)

Energizing inputs

Rated current I_n			
Overcurrent unit		1 A	5A
Earth-fault unit	0.2 A	1 A	
Thermal withstand capability			
- continuously	1.5 A	4 A	20 A
- for 1 s	50 A	100 A	500 A
Dynamic current withstand, half-wave value	100 A	250 A	1250 A
Input impedance	<750 m Ω /	<100 m Ω /	<20 m Ω
Rated frequency f_n	50 Hz		
Rated frequency on request	60 Hz		

Output contact ratings

Tripping contacts	
Terminals	65-66, 74-75
- Rated voltage	250 V dc/ac
- Carry continuously	5 A
- Make and carry for 0.5 s	30 A
- Make and carry for 3.0 s	15 A
- Breaking capacity for dc, when the control circuit time-constant L/R < 40 ms, at 48/110/220 V dc	5 A/3 A/1 A
Signalling contacts	
Terminals	70-71-72, 68-69, 77-78, 80-81
- Rated voltage	250 V dc/ac
- Rated current	5 A
- Make and carry for 0.5 s	10 A
- Make and carry for 3.0 s	8 A
- Breaking capacity for dc, when the control circuit time-constant L/R < 40 ms, at 48/110/220 V dc control circuit voltage	1 A/0.25 A/0.15 A

External control inputs

Blocking, remote reset or remote setting input	10-11
External control voltage level	18...265 V dc or 80...265 V ac
Typical control current of input circuit	2...20 mA

Power supply and output relay module

Supply and relay module, type SPTU 240 R1	80...265 V dc/ac
Supply and relay module, type SPTU 48 R1	18...80 V dc (on request)
Power consumption under quiescent/ operating conditions	4 W/ 6 W

Overcurrent unit of SPCJ 4D29

Low-set overcurrent stage I >	
Setting range	0.5...5.0 x I _n
Selectable modes of operation	
- definite time operation	
- operating time t>	0.05...300 s
- inverse definite minimum time (IDMT) mode of operation as per IEC 60255-3 and BS 142	Extremely inverse Very inverse Normal inverse Long-time inverse
- special type inverse characteristics	RI-type inverse RXIDG-type inverse
- time multiplier k	0.05...1.0
High-set overcurrent stage I>>	
Setting range	0.5...40 x I _n and ∞
Operating time t>>	0.04...300 s

Note!

If the setting is higher than 2.5 x I_n, the maximum continuous carry (4 x I_n) and the levelling out of the I.D.M.T -curves at high current levels must be noted.

Note!

The high-current end of any inverse time characteristic is determined by the high-set stage which, when started, inhibits the low-set stage operation. The trip time is thus equal to the set t>> for any current higher than I>>. In order to get a trip signal, the stage I>> must also of course be linked to a trip output relay.

Earth-fault unit of SPCJ 4D29

Low-set neutral overcurrent stage I ₀ >	
Setting range	0.1...0.8 x I _n
Selectable modes of operation	
- definite time operation	
- operating time t ₀ >	0.05...300 s
- inverse definite minimum time (IDMT) mode of operation as per IEC 60255-3 and BS 142	Extremely inverse Very inverse Normal inverse Long-time inverse
- special type inverse characteristics	RI-type inverse RXIDG-type inverse
- time multiplier k ₀	0.05...1.0

Note!

The high-current end of any inverse time characteristic is determined by the high-set stage which, when started, inhibits the low-set stage operation. The trip time is thus equal to the set t₀>> for any current higher than I₀>>. In order to get a trip signal, the stage I₀>> must also of course be linked to a trip output relay.

High-set neutral overcurrent stage I ₀ >>	
Setting range	0.1...10.0 x I _n and ∞
Operating time t ₀ >>	0.05... 300 s

Data transmission

Transmission mode	Fibre optic serial bus
Data code	ASCII
Selectable data transfer rates	4800 or 9600 Bd

Fibre optic bus connection modules
with integral power unit

- for plastic core cables	SPA-ZC 17 BB
- for glass fibre cables	SPA-ZC 17 MM

Fibre optic bus connection modules
which are powered from the host relay

- for plastic core cables	SPA-ZC 21 BB
- for glass fibre cables	SPA-ZC 21 MM

Insulation Tests *)

Dielectric test IEC 60255-5	2 kV, 50 Hz, 1 min
Impulse voltage test IEC 60255-5	5 kV, 1.2/50 μ s, 0.5 J
Insulation resistance measurement IEC 60255-5	>100 M Ω , 500 Vdc

Electromagnetic Compatibility Tests *)

High-frequency (1 MHz) burst disturbance test
IEC 60255-22-1

- common mode	2.5 kV
- differential mode	1.0 kV

Electrostatic discharge test IEC 60255-22-2 and
IEC 61000-4-2

- contact discharge	6 kV
- air discharge	8 kV

Fast transient disturbance test IEC 60255-22-4
and IEC 61000-4-4

- power supply	4 kV
- I/O ports	2 kV

Environmental conditions

Specified ambient service temperature range	-10...+55°C
Long term damp heat withstand according to IEC 60068-2-3	< 95 % at 40°C for 56 d
Transport and storage temperature range	-40...+70°C
Degree of protection by enclosure of the relay case as per IEC 60529 when panel mounted	IP 54
Mass of the relay, when flush mounted	3.5 kg

*) The tests do not apply to the serial port, which is used exclusively for the bus connection module.