

SPA-ZC 21

Bus connection module

User's manual and Technical description



Data subject to change without notice

General

The bus connection module acts as an interfacing unit between a SPACOM device and the fibre-optic SPA bus. The bus connection module converts incoming optical signals from the SPA bus to electrical RS485 or SPA (+5 V) signals for the SPACOM devices and vice versa, see Fig. 1. The bus connection module is plugged into the D-type subminiature connector on the

rear plate of the host device. The bus connection module SPA-ZC21 can be used in combination with any SPACOM device provided with a 9-pin D-type connector. Further, by means of a set of optional mounting accessories the bus connection module can be connected to a SACO data communication and reporting unit.

Principle of operation

The bus connection module is powered from the D-type connector of the host device.

The required data communication mode is selected with DIP switches on the front panel. When the SPA mode of communication is to be used switches 1 and 2 must be set in position 1 and switches 3 and 4 in position 0. To select the RS485 mode of communication switches 1 and 2 have to be set in position 0 and switches 3 and 4 in position 1.

Echo checking in the communication is selected with switch 5 (SLAVE/MASTER). When the connection module is connected to a slave device switch 5 should be set in position 1 (echo checking on). When the bus connection module is connected to a master device, for instance, a SACO unit, switch 5 should be set in position 0 (echo checking off).

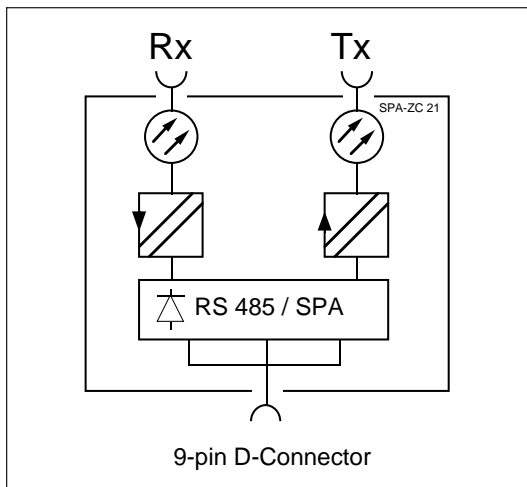

Fig. 1. Block diagram of bus connection module SPA-ZC 21.

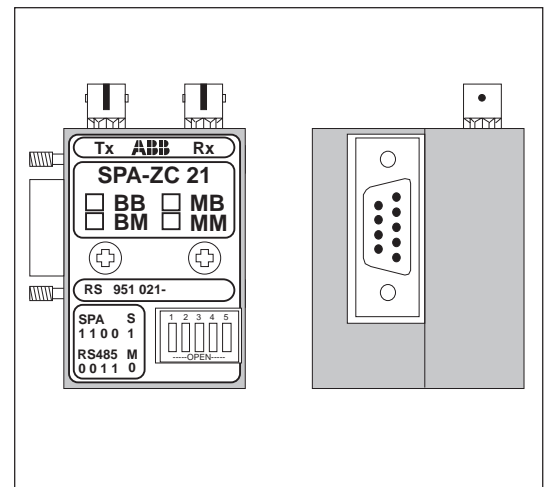

Fig. 2. Front panel and general appearance of bus connection module SPA-ZC 21.

Construction

The bus connection module SPA-ZC21 consists of two 32 mm x 42 mm printed circuit boards interconnected with a 10-pin connector strip and housed in a sheet steel case.

The incoming optical fibre is connected to the receiver input Rx and the outgoing optical fibre

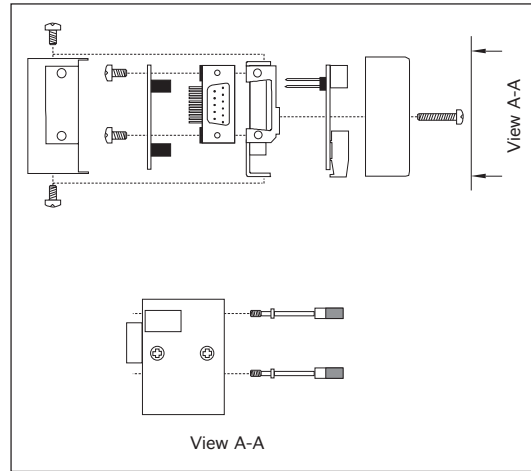

Fig. 3. Mechanical construction of bus connection module SPA-ZC21.

to the transmitter output Tx. When fibre optic cables are laid out special attention must be paid to the instructions concerning handling, mounting, connection, etc. of optical fibres. For additional information, see manual 34 SPA 13 EN1 "Plastic-core fibre optic cables. Features and instructions for mountig".

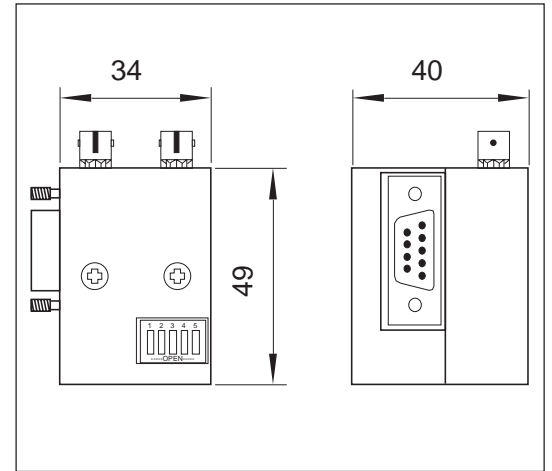

Fig. 4. Dimensional drawing of bus connection module SPA-ZC 21.

Optical/electrical connection

The bus connection module can be provided with connectors for two plastic fibre cables, two glass fibre cables or one of each. The SPA or RS485 communication mode is used between the SPACOM device and the bus connection module. Between two SPACOM devices information is transmitted through the optical fibre.

The optical fibres are provided with opto-connectors fitting into the corresponding connectors of the bus connection module. The optical fibres can be routed to the bus connection module from below or from above, see Fig.5, and the bus connection module is matched accordingly as described in the following:

Unwind the two cross-slotted screws, disassemble the cover, pull out the upper PCB carefully and turn it 180°. Push it carefully back into the pin connector, so that the pins of the connector strip

fit into the female terminals. Also turn the cover 180°, refit it and fix it with the two cross-slotted screws.

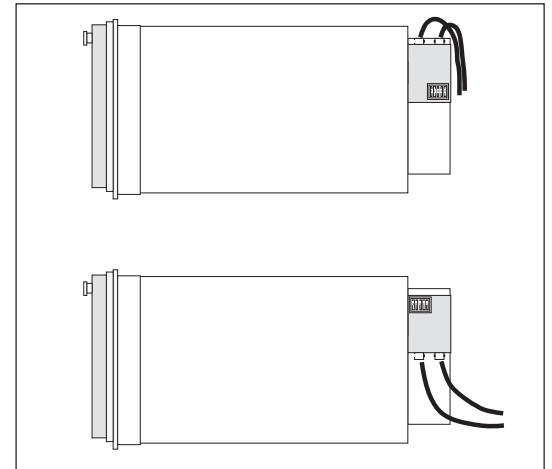
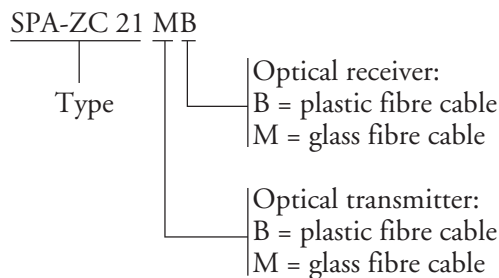

Fig. 5. Routing directions for the optical fibres.

Type designation



Type designation	Transmitter	Receiver
SPA-ZC 21BB	PLASTIC	PLASTIC
SPA-ZC 21BM	PLASTIC	GLASS
SPA-ZC 21MB	GLASS	PLASTIC
SPA-ZC 21MM	GLASS	GLASS

When the type designation is provided with the extension /S, the optional mounting accessories needed for the SACO devices are delivered together with the bus connection module. Example SPA-ZC 21MM/S



ABB Oy

Substation Automation

P.O.Box 699

FIN-65101 VAASA

Finland

Tel. +358 (0)10 22 11

Fax.+358 (0)10 22 41094

www.abb.com/substationautomation