

SDS-8842
Trusted™ Industrial Control System

Trusted™ Versatile FTA - T8842

GENERAL ASSEMBLY

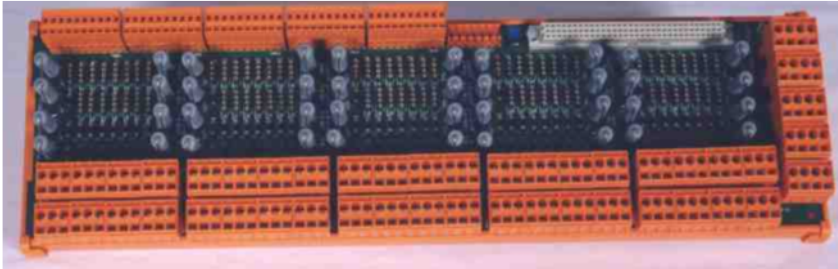

DESCRIPTION

The Trusted™ Versatile Field Termination Assembly (VFTA) is designed to act as the main interface between field devices associated with the detection and suppression of fire and gas hazards, and the Trusted™ TMR Zone Interface Module T8448.

Each channel of the VFTA is configurable to enable a variety of field devices to be connected. These include devices generating both analogue and digital input signals, and output devices requiring a digital signal at up to 40V dc.

The 40 channels are arranged in five power groups each comprising eight identical channels. Each power group is supplied from dual 24V dc feeds which are 'commoned' via diodes on the VFTA. The supply is then fed to each channel within the group.

The supply voltage to the field is fed via a 315mA fuse. The incoming signal (0-20mA) from the field device is fed through a 50mA fuse which effectively limits the input signal. The voltage developed across an input 250R resistor (high precision 0.1%) is used by the input module to detect the field device status.

The cable linking the 40 channels on the input module to the VFTA is terminated at five 10-way connectors. The dual 24V dc power supplies are connected to the VFTA via five 4-way connectors. Forty 3-way connectors are used for the field loops.

The VFTA is designed to be mounted on either of the TS32 or TS35 DIN rails in the horizontal or vertical positions as required.

FEATURES

- Forty input channels per VFTA
- Industry standard field device connections (3-wire)
- Standard DIN rail compatibility
- Simple configuration using plug-in fuses
- Simple installation and connection
- 24V dc operation
- Fused field power supply per channel
- Designed for use with current 'sinking' and 'sourcing' field devices

SDS-8842
Trusted™ Industrial Control System

Trusted™ Versatile FTA - T8842

BLOCK DIAGRAM

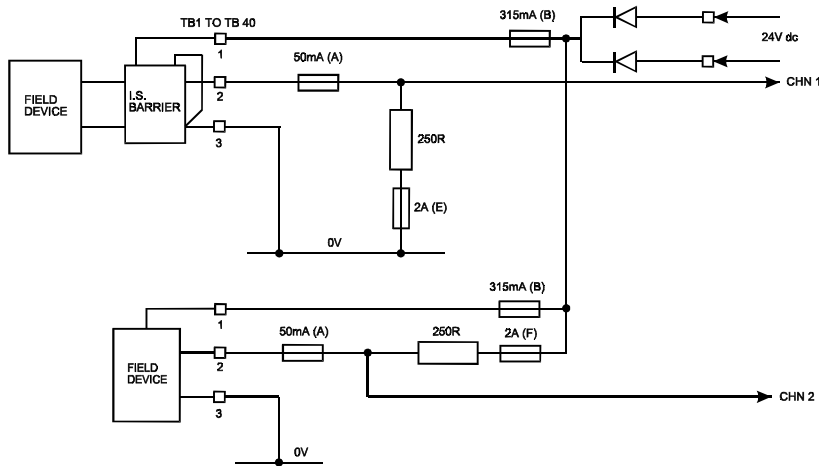

Single Channel Schematic for Current Sinking Gas Inputs

ELECTRICAL SPECIFICATION

Voltage Range (Field Supply)	18 to 28V dc
Fuses	40-off 2A 40-off 315mA 40-off 50mA
Maximum Current (Field Supply)	2.52A per power group
Recommended Operating Current	220mA per channel
Power Consumption (Field Supply)	9W maximum
Signal Input range	0-20mA

MECHANICAL SPECIFICATION

Dimensions (HxWxD):
110mm x 360mm x 68mm
(4.3ins x 14.2ins x 2.6ins)

Weight (fully populated)
950gms
(2.1lbs)

ENVIRONMENTAL

Operating Temperature:

-5°C to 60°C
(23°F to 140°F)

Operating Humidity:

5 to 95%, non-condensing

Vibration:

10 to 57Hz ±0.075mm
57 to 150Hz 1.0g

Shock:

15g, ½ sine wave, 11ms

EMI (IEC 801):

ESD
Air discharge to 15kV.
Contact discharge to 8kV

Radiated Fields
10V/m, 27MHz to
500MHz

Transients and Bursts

2kV, 2.5kHz for
t=60 seconds