

# SIEMENS

## SIMATIC

ET 200S distributed I/O  
Power module PM-E  
DC24..48V/AC24..230V  
(6ES7138-4CB11-0AB0)  
Manual

Preface

---

Properties

---

1

Parameters

---

2

Diagnostics

---

3

Configuring

---

4

## Safety Guidelines

This manual contains notices you have to observe in order to ensure your personal safety, as well as to prevent damage to property. The notices referring to your personal safety are highlighted in the manual by a safety alert symbol, notices referring only to property damage have no safety alert symbol. These notices shown below are graded according to the degree of danger.

<b>⚠ DANGER</b>
indicates that death or severe personal injury <b>will</b> result if proper precautions are not taken.
<b>⚠ WARNING</b>
indicates that death or severe personal injury <b>may</b> result if proper precautions are not taken.
<b>⚠ CAUTION</b>
with a safety alert symbol, indicates that minor personal injury can result if proper precautions are not taken.
<b>CAUTION</b>
without a safety alert symbol, indicates that property damage can result if proper precautions are not taken.
<b>NOTICE</b>
indicates that an unintended result or situation can occur if the corresponding information is not taken into account.

If more than one degree of danger is present, the warning notice representing the highest degree of danger will be used. A notice warning of injury to persons with a safety alert symbol may also include a warning relating to property damage.

## Qualified Personnel

The device/system may only be set up and used in conjunction with this documentation. Commissioning and operation of a device/system may only be performed by **qualified personnel**. Within the context of the safety notes in this documentation qualified persons are defined as persons who are authorized to commission, ground and label devices, systems and circuits in accordance with established safety practices and standards.

## Prescribed Usage

Note the following:

<b>⚠ WARNING</b>
This device may only be used for the applications described in the catalog or the technical description and only in connection with devices or components from other manufacturers which have been approved or recommended by Siemens. Correct, reliable operation of the product requires proper transport, storage, positioning and assembly as well as careful operation and maintenance.

## Trademarks

All names identified by ® are registered trademarks of the Siemens AG. The remaining trademarks in this publication may be trademarks whose use by third parties for their own purposes could violate the rights of the owner.

## Disclaimer of Liability

We have reviewed the contents of this publication to ensure consistency with the hardware and software described. Since variance cannot be precluded entirely, we cannot guarantee full consistency. However, the information in this publication is reviewed regularly and any necessary corrections are included in subsequent editions.

# Preface

## Preface

### Purpose of the manual

This manual supplements the *ET 200S Distributed I/O System* Operating Instructions. General functions for the ET 200S are described in the *ET 200S Distributed I/O System* Operating Instructions.

The information in this document along with the operating instructions enables you to commission the ET 200S.

### Basic knowledge requirements

To understand these operating instructions you should have general knowledge of automation engineering.

### Scope of the manual

This manual applies to this ET 200S module. It describes the components that are valid at the time of publication.

### Recycling and disposal

Thanks to the fact that it is low in contaminants, this ET 200S module is recyclable. For environmentally compliant recycling and disposal of your electronic waste, please contact a company certified for the disposal of electronic waste.

### Additional support

If you have any questions relating to the products described in these operating instructions, and do not find the answers in this document, please contact your local Siemens representative.

<http://www.siemens.com/automation/partner>

The portal to our technical documentation for the various SIMATIC products and systems is available at:

<http://www.siemens.com/automation/simatic/portal>

The online catalog and ordering system are available at:

<http://www.siemens.com/automation/mall>

## Training center

We offer courses to help you get started with the ET 200S and the SIMATIC S7 automation system. Please contact your regional training center or the central training center in D -90327, Nuremberg, Germany.

Phone: +49 (911) 895-3200.

<http://www.siemens.com/sitrain>

## Technical Support

You can reach technical support for all A&D projects

- using the support request web form:  
<http://www.siemens.com/automation/support-request>
- Phone: + 49 180 5050 222
- Fax: + 49 180 5050 223

For more information about our technical support, refer to our Web site at

<http://www.siemens.de/automation/service>

## Service & Support on the Internet

In addition to our documentation services, you can also make use of our comprehensive online knowledge base on the Internet.

<http://www.siemens.com/automation/service&support>

There you will find:

- Our Newsletter, which constantly provides you with the latest information about your products.
- The right documentation for you using our Service & Support search engine.
- The bulletin board, a worldwide knowledge exchange for users and experts.
- Your local contact for Automation & Drives in our contact database.
- Information about on-site services, repairs, spare parts. Lots more can be found on our "Services" pages.

# Table of contents

	<b>Preface</b> .....	<b>3</b>
<b>1</b>	<b>Properties</b> .....	<b>7</b>
	1.1 Power module PM-E DC24..48V/AC24..230V (6ES7138-4CB11-0AB0) .....	7
<b>2</b>	<b>Parameters</b> .....	<b>11</b>
<b>3</b>	<b>Diagnostics</b> .....	<b>13</b>
	3.1 Diagnostics using LED display.....	13
	3.2 Error types.....	14
<b>4</b>	<b>Configuring</b> .....	<b>15</b>
	4.1 Configuring the address space .....	15
	<b>Index</b> .....	<b>17</b>



## Properties

### 1.1 Power module PM-E DC24..48V/AC24..230V (6ES7138-4CB11-0AB0)

#### Properties

The power module PM-E DC24V..48V/AC24..230V

- Monitors the supply voltage for all the electronic modules in the voltage group. The supply voltage is fed in by means of the TM-P terminal module.
- Can be used universally and can be assigned parameters for DC and AC load voltage for use with any electronic module.
- Is required at least once for the ET 200S (to the right of the interface module).  
Exception: Design of the ET 200S with an IM151-1 COMPACT
- Control interface (PIQ) and feedback interface (PII) in the process image for option handling.
- The current status of the power module is stored in the status byte in the process input image (PII). This is updated irrespective of whether the "No Load Voltage" diagnosis has been enabled.
- Is additionally equipped with a replaceable fuse (5 mm x 20 mm).

#### Replacing the fuse:

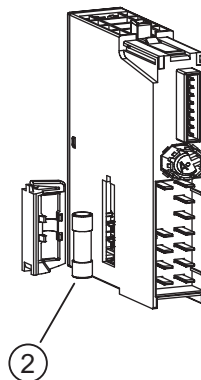
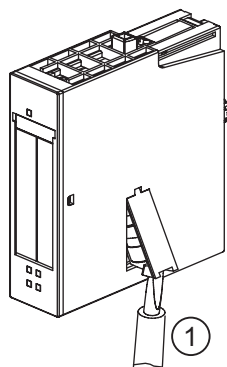

- ① Screwdriver with 3 mm blade  
② Fuse

**Maximum configuration per voltage group**

The number of modules that can be connected depends on the total current of all modules in a voltage group. This total must not exceed the maximum current carrying capacity.

**Address space of inputs/outputs**

Address space of inputs/outputs by selecting the following as an option:

Options	Address space of the inputs	Address space of the outputs
Status byte (S)	1 byte	--
Option handling (O)	8 bytes	8 bytes
Status byte and option handling (SO)	9-byte inputs	9 bytes (9th byte not relevant)

**General terminal assignment**

**Note**

Terminals A4 and A8 are only available at specified terminal modules.

Terminal assignment PM-E DC24..48V/AC24..230V (6ES7138-4CB11-0AB0)				
Terminal	Assignment	Terminal	Assignment	Notes
2	L+/L1	6	L+/L1	<ul style="list-style-type: none"> <li>L+/L1: Rated load voltage 24 VDC to 48 VDC</li> <li>M: Chassis ground</li> <li>N: Neutral conductor</li> <li>AUX1: Protective-conductor terminal or potential bus (freely usable up to 230 VAC)</li> </ul>
3	M/ N	7	M/ N	
A4	AUX1	A8	AUX1	

Usable terminal modules

Terminal modules that can be used for PM-E DC24..48V/AC24..230V (6ES7138-4CB11-0AB0)			
TM-P15C23-A1 (6ES7193-4CC30-0AA0)	TM-P15C23-A0 (6ES7193-4CD30-0AA0)	TM-P15C22-01 (6ES7193-4CE10-0AA0)	← Spring terminal
TM-P15S23-A1 (6ES7193-4CC20-0AA0)	TM-P15S23-A0 (6ES7193-4CD20-0AA0)	TM-P15S22-01 (6ES7193-4CE00-0AA0)	← Screw-type terminal
TM-P15N23-A1 (6ES7193-4CC70-0AA0)	TM-P15N23-A0 (6ES7193-4CD70-0AA0)	TM-P15N22-01 (6ES7193-4CE60-0AA0)	← Fast Connect
			<p>Wiring examples</p>

Block diagram

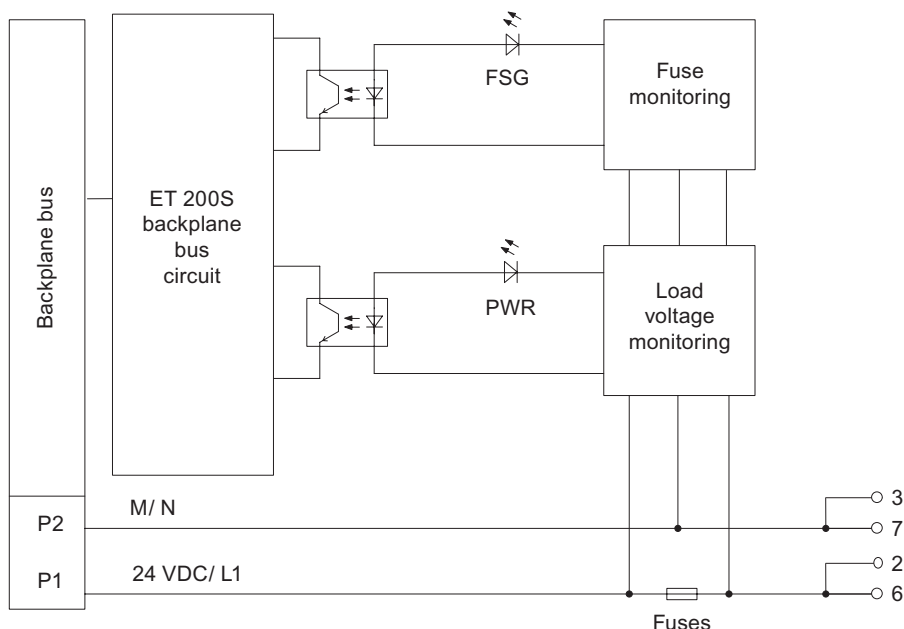

Figure 1-1 Block diagram of the PM-E DC24..48V/AC24..230V

**Technical data PM-E DC24..48V/AC24..230V (6ES7138-4CB11-0AB0)**

<b>Dimensions and weight</b>	
Dimension B (mm)	15
Weight	34 g
<b>Voltages, currents, potentials</b>	
Rated load voltage	24 VDC to 56.7 VDC 24 V to 48 V / 120 V / 230 V AC
• Overvoltage protection	Yes
Protection with automatic circuit breakers	Yes, tripping characteristic B, C
Max. current-carrying capacity	10 A
• For 24 to 56.7 VDC	Up to 30°C: Max. 10 A Up to 40°C: Max. 9 A Up to 60°C: Max. 7 A
• For 24 to 48/120/230 VAC	Up to 30°C: Max. 8 A Up to 40°C: Max. 7 A Up to 60°C: Max. 5 A
• Short-circuit protection	Yes, IEC 127-2/1, 250 V, 10 A, fast fuse (5 x 20 mm), replaceable <sup>1</sup>
<b>Electrical isolation</b>	
• Between rated load voltage and backplane bus	Yes
• Between the power modules	Yes
Insulation test voltage	1500 VAC
Current consumption from backplane bus	Max. 9.5 mA
• From load voltage L1/L+ (no load)	Max. 9 mA
Power dissipation of the module	Max. 5 W
Parameter length	3 bytes
<b>Status, interrupts, diagnostics</b>	
Diagnostic function	Yes
• Group error	Red "SF" LED
• Load voltage monitoring	Green "PWR" LED
• Fuse	Green LED "FSG"
• Diagnostic information can be displayed	Yes

<sup>1</sup> The fuses (order number: 6ES7193-4KA10-0AA0) for this module are only intended to serve as supplementary fuses. External overcurrent protection (suitable for branch circuits in accordance with the electrical engineering regulations that apply to your country) is required for the supply lines of the load circuit.

## Parameters

### Parameters

The following table lists the power module parameters.

Table 2-1 Parameters for power modules

PM-E DC24..48V/ AC24..230V <sup>1</sup>	Range of values	Default setting	Applicability
Diagnostics: No load voltage	Disable/enable	Disable	Power module
Diagnostics: Fuse blown	Disable/enable	Disable	Power module
Voltage type	DC/AC	DC	Power module
<sup>1</sup> The power module PM-E DC24..48V/AC24..230V (6ES7138-4CB11-0AB0) is not a direct replacement for the device with order number 6ES7138-4CB00-0AB0 for AC applications, because the supply voltage must be set to either AC or DC. In the case of DC applications, the new module does act as a direct replacement because the default setting of the new parameter is "DC". If you want to replace the device with order number 6ES7138-4CB00-0AB0 in AC applications, you have to create a new hardware configuration and set the value "AC" in the "Voltage type" parameter.			

The parameters are explained below.

#### Diagnostics: No load voltage

Use this parameter to enable a diagnostic message because there is no load voltage.

If there is no load voltage, only the diagnostic message of the affected power module is sent to the DP master. The SF error LEDs of all modules in the relevant voltage group light up.

#### Diagnostics: Fuse blown

Use this parameter to enable a diagnostic message because of a blown fuse.

If a fuse has blown, only the diagnostic message of the affected power module is sent to the DP master. The SF error LEDs of all modules in the relevant voltage group light up.

#### Voltage type

Use this parameter to select the load voltage that is connected to the power module: Direct (DC) voltage or alternating (AC) voltage.

This enables the correct diagnostics to be obtained when the load voltage fails or a fuse blows.



## Diagnostics

### 3.1 Diagnostics using LED display

#### Power module

LED displays on the power module:

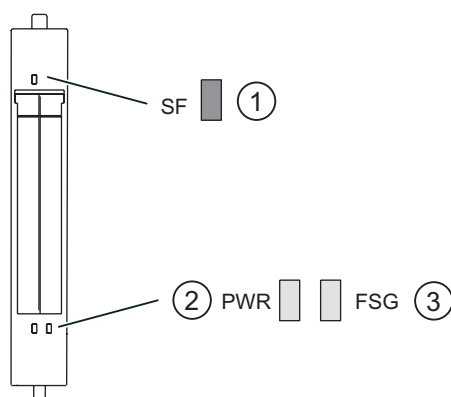

- ① Batch error (red)
- ② Load voltage (green)
- ③ Fuse (green)

#### Status and error displays by means of LEDs on power modules

The table below shows the status and error displays on the power module.

Event (LEDs)			Cause	Remedy
SF	PWR	FSG		
On			No parameter assignment or incorrect module plugged in. A diagnostic message is pending.	Check the parameter assignment. Evaluate the diagnostics.
	Off		There is no load voltage at the power module.	Check the load voltage.
		Off	The fuse in the power module has tripped.	Replace the fuse.

### 3.2 Error types

#### Power module error types

The diagnostic message is reported on channel 0 and applies to the entire module.

The table below shows the types of errors affecting power modules

Table 3-1 Power module error types

	<b>Error type</b>	<b>Meaning</b>	<b>Remedy</b>
17 <sub>D</sub>	10001: Encoder or load voltage missing	Supply voltage not present or too low.	Correct the process wiring. Check the supply voltage.
18 <sub>D</sub>	10010: Fuse is defective	The fuse in the power module has tripped.	Replace the fuse.

## Configuring

### 4.1 Configuring the address space

#### Address area for option handling and status byte

You can control and monitor option handling, and evaluate the status byte of the power module using the control (PIO) and feedback interface (PII).

The address range of the control (PIO) and feedback interface (PII) depends on how the corresponding entry in the configuration software is configured, or which entry has been selected.

This table shows the PII feedback interface and the PIO control interface for different entries.

Table 4-1 PII feedback interface and PIO control interface

With STEP 7, HW Config or COM PROFIBUS or other configuration software	PII feedback interface		PIO control interface	
	Usual entry for the power module	---		---
Ends in ...S	IBx	Status byte	---	
Ends in ...O	IBx ::: IBx+7	Option handling	QBx ::: QBx+7	Option handling
Ends in ...SO	IBx ::: IBx+7	Option handling	QBx ::: QBx+7	Option handling
	IBx+8	Status byte	QBx+8	Not applicable

### Status byte for power modules

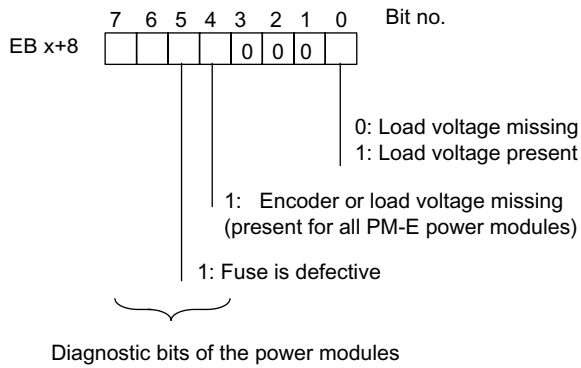

Figure 4-1 Assignment of status byte for power modules

# Index

## B

Basic knowledge requirements, 3  
Block diagram, 9

## D

Disposal, 3

## I

Internet  
Service & Support, 4

## M

Maximum configuration, 8

## P

Parameters  
For power modules, 11  
Power modules, 13  
Error types, 14  
Parameters, 11  
Properties, 7

## R

Recycling, 3

## S

Scope  
Manual, 3  
Service & Support, 4

## T

Technical data, 10  
Technical Support, 4  
Terminal assignment, 8  
Training center, 4

