





V-Contact VSC

Medium voltage vacuum contactors



ABB

	1
DESCRIPTION	3
	2
CONTACTOR SELECTION AND ORDERING	9
	3
SPECIFIC PRODUCT CHARACTERISTICS	17
	4
OVERALL DIMENSIONS	29
	5
ELECTRIC CIRCUIT DIAGRAM	35

DESCRIPTION

General	4
Versions available	4
Fields of application	5
Conformity with Standards	5
Approvals	5
Operating characteristics	5
Main technical characteristics	5
Electrical life	5
Interruption principle	6
Magnetic drive	6
Control/feeder module	7
Technical documentation	8
Quality System	8
Test Laboratory	8
Environmental Management System	8
Health and Safety Management System	8

DESCRIPTION

General

The medium voltage V-Contact VSC contactors are apparatus suitable for operating in alternating current and are normally used to control users requiring a high number of hourly operations. The V-Contact VSC contactor introduces the drive with permanent magnets, already widely used, experimented and appreciated in medium voltage circuit-breakers, into the worldwide panorama of medium voltage contactors.

The experience acquired by ABB in the field of medium voltage circuit-breakers fitted with drives with "MABS" permanent magnets, has made it possible to develop an optimised version of the actuator (bistable MAC drive) for medium voltage contactors.

The drive with permanent magnets is activated by means of an electronic multi-voltage feeder. The feeders differ according to the integrated functions and to the auxiliary power supply voltage.

Three bands of power supply are available with which all the voltage values required by the major international Standards can be covered.

Each feeder is able to take any voltage value within its own operating band.

Versions available

The V-Contact VSC contactors are available in the following versions:

Version	Rated voltage	Type
Fixed	3.6 kV	VSC 3
	7.2 kV	VSC 7
	12 kV	VSC 12
Withdrawable	7.2 kV	VSC/P 7
	12 kV	VSC/P 12

All the contactors mentioned above are available, on request, in one of the two following versions.

- **SCO** (Single Command Operated): closing takes place by supplying auxiliary power to the special input of the multi-voltage feeder. On the other hand, opening takes place when the auxiliary power is either voluntarily cut off (by means of a command) or involuntarily (for lack of auxiliary power in the installation).
- **DCO** (Double Command Operated): closing takes place by supplying the input of the closing command of the apparatus in an impulsive way. On the other hand, opening takes place when the input of the opening command of the contactor is supplied in an impulsive way.



Fields of application

The V-Contact VSC contactors are suitable for controlling electrical apparatus in industry, in the service sector, in the marine sector, etc.

Thanks to the breaking technique with vacuum interrupters, they can operate in particularly difficult environments.

They are suitable for control and protection of motors, transformers, power factor correction banks, switching systems, etc. Fitted with suitable fuses, they can be used in circuits with fault levels up to 1000 MVA (VSC7 - VSC12).

Compliance with Standards

V-Contact VSC contactors comply with the Standards of the major industrialised countries and in particular with the EC 60470 (2000) Standards.

Approvals

Approval by the DNV, RINA and LL.RR shipping registers is foreseen.

For these versions, please contact ABB.

Operating characteristics

- Ambient temperature: $-5\text{ °C} \dots +40\text{ °C}$
- Relative humidity: $< 95\%$ (without condensation)
- Altitude: $< 1000\text{ m s.l.m.}$

For other conditions, please contact us.

Main technical characteristics

- Chopping current value $\leq 0.5\text{ A}$
- Maintenance-free
- Suitable for installation in prefabricated substations and switchgear both of the card (slim line) and traditional type
- High number of operations
- Direct checking of contact wear
- Long electrical and mechanical life
- Remote control
- Multi-voltage feeder
- Bistable drive of the type with permanent magnets
- Behaviour on power cut adjustable by the customer (instantaneous or delayed opening) in the SCO versions and, should the undervoltage accessory be required, DCO.

Electrical life

The electrical life of V-Contact VSC contactors is defined in category AC3.



DESCRIPTION



Interruption principle

The main contacts operate inside the vacuum interrupters (the level of vacuum is extremely high: 13×10^{-5} Pa).

On opening, there is rapid separation of the fixed and moving contacts in each contactor interrupter.

Overheating of the contacts, generated at the moment they separate, causes formation of metallic vapours

which allow the electric arc to be sustained up to the first passage through zero current.

On passage of zero current, cooling of the metallic vapours allows recovery of high dielectric resistance able to withstand high values of the return voltage.

For motor switching, the value of the chopped current is less than 0.5 A with extremely limited overvoltages.

Schematic cross-section of the vacuum interrupter.

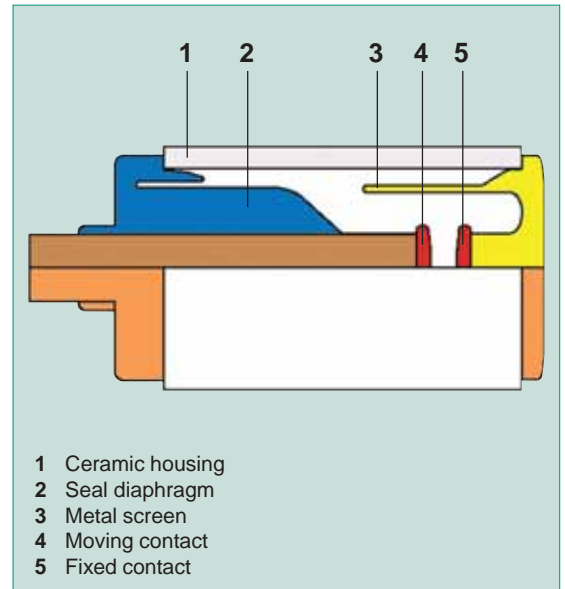

“MAC” magnetic drive

ABB has implemented this technology in the field of contactors on the basis of experience gained in the field of circuit-breakers with magnetic drive.

The magnetic drive adapts perfectly to this type of apparatus thanks to its precise and linear travel.

The drive, which is of bistable type, is fitted with an opening and a closing coil.

The two coils - individually energised - allow the drive mobile armature to be moved from one of the two stable positions to the other.

The drive shaft is solid with the mobile armature and held in position in a field generated by two permanent magnets (fig. A).

Energising the coil opposite to the magnetic latching position (fig. A) of the core, the magnetic field is generated (fig. B), which attracts and moves the mobile armature into the opposite position (fig. C).

Every opening and closing operation creates a magnetic field concordant with the one generated by the permanent magnets, with the advantage of keeping the intensity of the field itself constant during service, regardless of the number of operations carried out.

The energy needed for operation is not supplied directly by the auxiliary power supply, but is always "stored" in the capacitor which acts as an energy accumulator, and therefore operation always takes place with constant speeds and times, independently of the divergence of the power supply voltage from the rated value.

The auxiliary power supply has the only aim of keeping the capacitor charged.

Consumption is therefore minimal. The power required is less than 5 W. In order to re-instate the rated power value in the capacitor after an operation, there is an inrush of 15 W for a duration of a few tens of milliseconds.

For the reasons indicated above, both for the DCO and for the SCO version it is necessary to supply the auxiliary circuits which recharge the capacitor with a continuous auxiliary power supply of 5W (this value can reach 15W for a few milliseconds immediately following each operation).

Careful selection of the components and a precise design make the electronic multi-voltage feeder extremely reliable, unaffected by electromagnetic interference generated by the surrounding environment and free of any emissions which may affect other apparatus placed in the vicinity.

These characteristics have made it possible for the V-Contact VSC contactors to pass the electromagnetic compatibility tests (EMC) and obtain the CE mark.

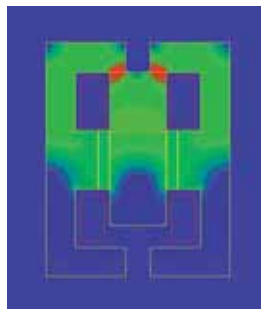

Fig. A - Magnetic circuit in the closed position.

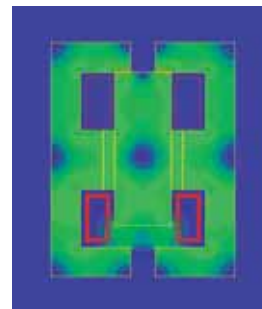

Fig. B - Magnetic circuit with the opening coil supplied.

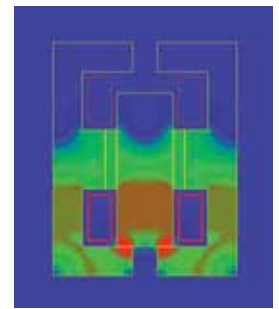
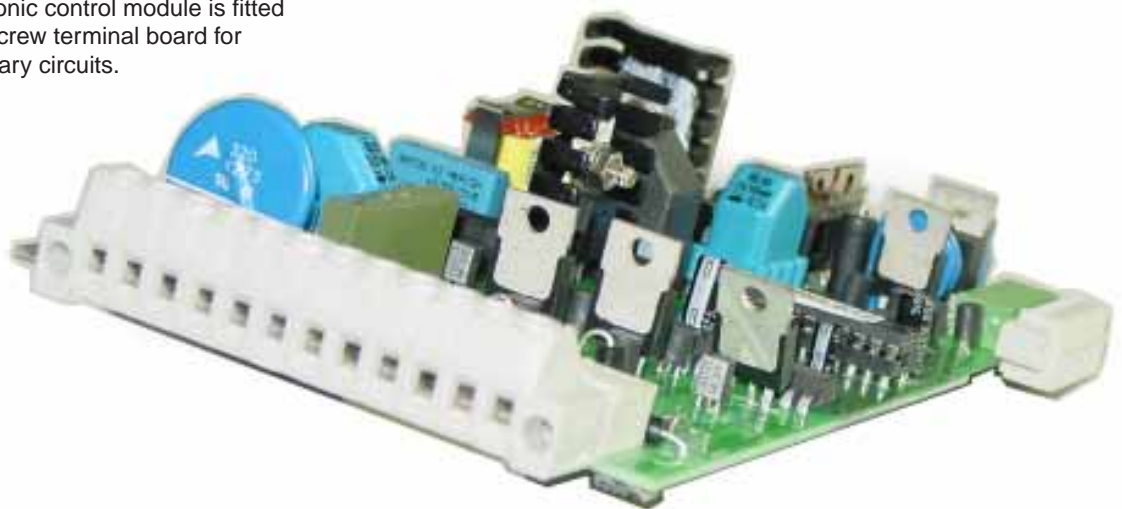

Fig. C - Magnetic circuit in the open position.

Control Module / feeder

As standard, the electronic control module is fitted with a connector with screw terminal board for connection of the auxiliary circuits.



DESCRIZIONE

Technical documentation

For more in-depth technical and application aspects of the VSC contactors, also consult the publication on the REF542*plus* multi-function control and protection unit - code 1VTA100001.

Quality System

Conforms to the ISO 9001 Standards, certified by an external independent organization.

Test laboratory

Conforms to the UNI CEI EN ISO/IEC 17025 Standards.

Environmental Management System

Conforms to the ISO 14001 Standards, certified by an external independent organization.

Health and Safety Management System

Conforms to the OHSAS 18001 Standards, certified by an external independent organization.



CONTACTOR SELECTION AND ORDERING

General characteristics	11
Standard fittings	12
Optional accessories	14

CONTACTOR SELECTION AND ORDERING

General characteristics		Ref. to the IEC 60470 Standard (05-2000)	VSC 3		
			Contactor 3.4.105	Starter 3.4.110	Combined with fuses 3.4.110.5
Rated voltage	Ur [kV]	4.1	3.3	3.3	3.3
Rated insulation voltage	Ur [kV]	-	3.6	3.6	3.6
Withstand voltage at 50 Hz	Ud (1 min) [kV]	4.2	18	18	18
Impulse withstand voltage	Up [kVp]	4.2	30	30	30
Rated frequency	fr [Hz]	4.3	50-60	50-60	50-60
Rated service current	Ie [A]	4.101	320	320	(2)
Short-time withstand current for 1 s	Ik [A]	4.5	4.800	4.800	4.800
Rated peak current	Ip [kA peak]	4.6	12	12	12
Rated short-circuit time	tk [s]	4.7	1	1	1
Breaking capacity up to	Isc [kA]	4.107	-	-	50 (3)
Short-circuit making capacity up to	I _{ma} [kA]	4.107	-	-	50 (3)
Number of operations (rated values)					
Contactor SCO	[man./hour]	4.102	900	900	900
Contactor DCO	[man./hour]	4.102	900	900	900
Maximum rated admissible overcurrent for ½ period (peak value)	[kA]	-	55	-	-
Rated load and overload characteristics in category of use:					
(Category AC4) 100 closing operations	[A]	4.103,4.104	3.200	3.200	3.200
(Category AC4) 25 opening operations	[A]	4.103,4.104	2.400	2.400	2.400
Rated voltage of the switching devices and auxiliary circuits		4.8,4.9			
Feeder type1 (24 ... 60 DC)		■	■	■	■
Feeder type 2 (100 ... 125 AC-DC)		■	■	■	■
Feeder type 3 (220 ... 250 AC-DC)		■	■	■	■
Normal current	I _{th} [A]	4.4.101	320	320	(2)
Electrical life (category AC3) (4)	4.106	500,000	100,000	100,000	100,000
Electrical life at rated current	4.106	2,500,000	1,000,000	1,000,000	1,000,000
Mechanical life	4.106	2,500,000	1,000,000	1,000,000	1,000,000
Apparatus wear classification (type)	4.107.3	C	C	C	C
Short-circuit breaking capacity (O-3min-CO-3min-CO)	[A]	4.107,6.104	4,000	4,000	-
Short-circuit making capacity (O-3min-CO-3min-CO)	[peak A]	4.107,6.104	10,000	10,000	-
Limit above which the fuse blows (6)	[A]	4.107.3	-	-	(8)
Switching times					
Opening time (lower and upper limit)	[s]	-	20...30	20...30	20...30
Closing time (lower and upper limit)	[s]	-	20...30	20...30	20...30
Weight					
Fixed	[kg]	-	9	9	-
Withdrawable (excluding the fuses)	[kg]	-	-	-	-
Overall dimensions					
Fixed contactor					
Height	(H) [mm]	-	255	255	255
Depth	(W) [mm]	-	252	252	252
Profondità	(D) [mm]	-	206	206	206
Withdrawable contactor					
Height	(H) [mm]	-	-	-	-
Width	(W) [mm]	-	-	-	-
Depth	(D) [mm]	-	-	-	-
Tropicalisation (IEC 721-2-1)		-	■	■	■
			VSC 3 - 320 A		
Ultimate performances for (at a voltage of):	[kV]	-	2.2/2.5		3.3
- Motors	[kW]	-	500		750
- Transformers	[kVA]	-	670		1,000
- Capacitors	[kVAr]	-	330		500
Ultimate performances for back-to-back capacitor banks					
- Rated current	[A]	-	(8)		(8)
- Maximum transient current of the capacitor	[kA]	-	(8)		(8)
- Maximum transient frequency of capacitor connection	[kHz]	-	(8)		(8)

CONTACTOR SELECTION AND ORDERING

Standard fittings

1 MAC Drive with permanent magnets with capacitor for storing energy (1b)

2 Auxiliary contacts:

Contactor	Choices available	Normally open	Normally closed
VSC 3	1	5	-
	2	-	5
	3	3	2
	4	2	3
VSC 7 400 A	1	5	5
VSC 7 800 A	1	5	5
VSC 12	1	5	5
VSC/P 7	1 5 (SCO)	4 (DCO)	5
VSC/P 12	1 5 (SCO)	4 (DCO)	5

3 Multi-voltage feeder. Different power supply ranges are available:

- Feeder type 1: 24-60 V d.c.
- Feeder type 2: 110-130 V d.c./a.c. 50-60 Hz)
- Feeder type 3: 220-250 V d.c./a.c. 50-60 Hz)

4 Socket/plug with terminal at terminal box

5 Manual emergency opening operation

6 Mechanical Open/Closed indicator.

7 Opening delay selected among 0; 0.5; 1; 2; 3; 4 and 5 seconds (only for SCO version contactor)

8 Watchdog: the contactor opens automatically when the capacitor power drops below the safety limit.

9 Fuseholders (only for withdrawable contactor).

The withdrawable contactor is fitted with fuseholders able to hold DIN or BS type fuses according to what the customer requests.

The fuses must have the dimensions and striker of average type according to DIN 43625 Standards with maximum cartridge size $e=442\text{mm}$ and BS 2692 (1975) with maximum cartridge size $L=553\text{mm}$.

The electrical characteristics must conform to the IEC 282-1 (1974) Standards.

The fuseholder is fitted with a special kinematics mechanism which automatically opens the contactor when even a single fuse blows and prevents contactor closing when even a single fuse is missing.

10 Isolation interlock with the truck (only withdrawable contactor). This prevents isolation or racking-in the contactor into the switchgear if the apparatus is in the closed position, and also prevents contactor closing during the isolation run.

Characteristics of the auxiliary contacts of the contactor

Rated voltage:	24 ... 250 V AC-DC
Rated current I_{th}^2 :	10 A
Insulation voltage:	2500 V 50 Hz (1 min)
Electric resistance:	3 mOhm

The rated current and breaking capacity values in category AC11 and DC11 are indicated below.

Un	Cosφ	T	In	Icu
220 V ~	0.7	—	2.5 A	25 A
24 V –	—	15 ms	10 A	12 A
60 V –	—	15 ms	6 A	8 A
110 V –	—	15 ms	4 A	5 A
220 V –	—	15 ms	1 A	2 A

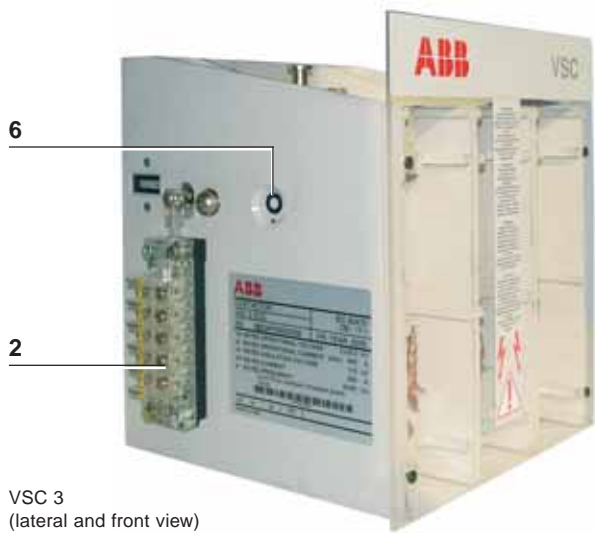

VSC 3
(lateral and front view)



VSC 3
(rear view)

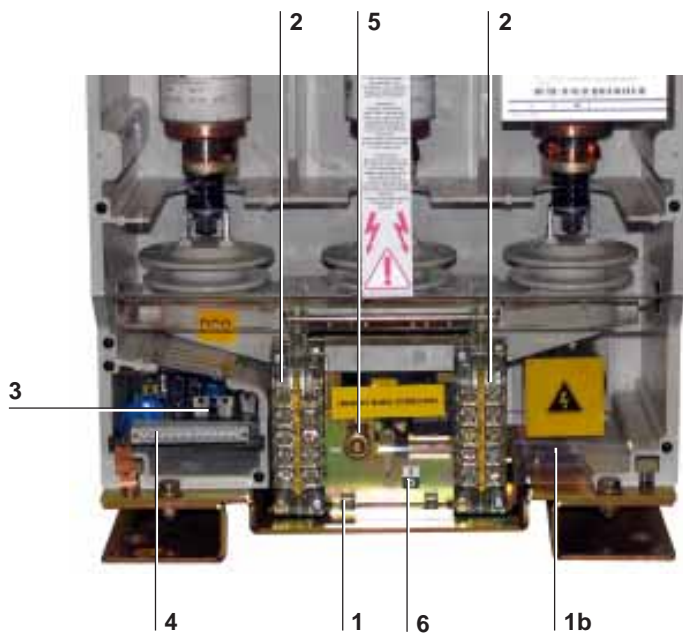

VSC 7 - VSC 12

SPECIFIC PRODUCT CHARACTERISTICS

Optional accessories

The table below indicates availability of the accessories in relation to the various types of contactor.

Table of accessory availability	VSC 3	VSC 7 400 A	VSC 7 800 A	VSC/P 7	VSC 12	VSC/P 12
1a Interfacing shaft on feeder side		■				
1b Interfacing shaft on capacitor side		■	■		■	
2a Mechanical operation counter	■	■	■		■	
2b Electric operation counter (impulse counter)				■		■
3 Undervoltage function (only DCO version)	■	■	■	■	■	■
4 Extended connections	■					
5 Adapter for fuses				■		■
6 Connection alternative to the fuses				■		■
7 Position contacts for connected isolated position in the truck				■		■
8 Isolation lock				■		■
9 Locking magnet in the withdrawable truck				■		■
10 Anti-insertion lock for different currents (1)				■		■

(1) Compulsory for PowerCube and UniGear switchgear.

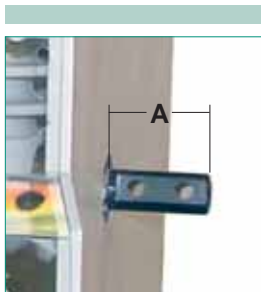

1 Interfacing shafts

These can be used to interface the apparatus with the kinematics of the switchgear to make interlocks and/or signals.

The interfacing shafts are available in two different lengths (A = 22 mm and 70 mm) and can be mounted on one or both sides of the contactor (as indicated in the following table).

Length A	22 mm		70 mm	
	Feeder side	Capacitor side	Feeder side	Capacitor side
VSC 3	--	--	--	--
VSC 7 400 A	■	■	■	■
VSC 7 800 A	--	■	--	■
VSC 12 400 A	--	■	--	■

Note: for the utilisation parameters (angles and forces applicable), please refer to the instruction manual.

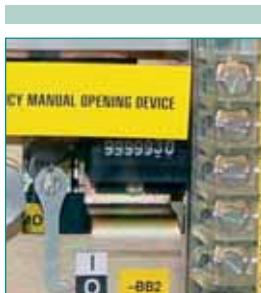

2 Operation counter

Mechanical operation counter for fixed versions, electric operation counter for withdrawable versions.

This is a device which counts the contactor closing cycles.



3 Undervoltage function (only available for DCO)

First of its type, the V-Contact VSC contactor is fitted with an undervoltage function with selectable delays of 0; 0,5; 1; 2; 3; 4; 5 s.

This accessory must be specified at the time of order because it cannot be mounted at a later stage.

4 Extended connections (terminals)

These allow the centre distance between terminals to be taken from 65 mm to 92 mm.

This accessory must be specified at the time of order because it cannot be mounted at a later stage.



5 Adapter for application of fuses

The kit includes all the accessories needed to adapt and mount three fuses (according to DIN Standards with dimension **e less than 442 mm**; according to BS Standards with dimension **L less than 553 mm**).

The kit can be installed directly onto the fuseholder supports. The fuses must have dimensions and striker of average type according to DIN 43625 and BS 2692 (1975) Standards. The electrical characteristics must conform to the IEC 282-1 (1974) Standards.

To select the fuses, see "Conditions of use according to the load" - chapter 3.

The adaptation kits are available in the following types:

3A For fuses according to DIN Standards with distance **e = 192 mm**

3B For fuses according to DIN Standards with distance **e = 292 mm**

3C For fuses according to BS Standards ($2 \times 8 \times L = 235 \text{ mm}$)

3D For fuses according to BS Standards ($4 \times 10 \times L = 305 \text{ mm}$)

3E For fuses according to BS Standards ($4 \times 10 \times L = 410 \text{ mm}$)

3F For fuses according to BS Standards with distance **L = 454 mm**.

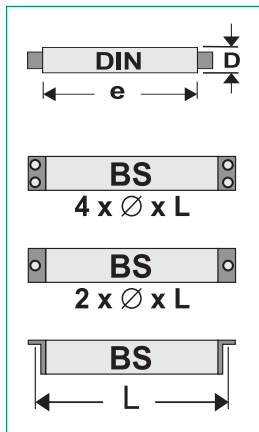

6 Connections alternative to the fuses

The kit includes three flat copper busbars and fixing screws to be installed when the fuses are not needed.

The kit can be installed directly onto the fuseholder supports.

SPECIFIC PRODUCT CHARACTERISTICS



7 Position contacts for connected/isolated position in the truck

These signal the position of the truck in the enclosure/PowerCube module. The kit includes a set of 10 auxiliary contacts. This accessory must always be requested for contacts to be used in UniGear type ZS1 switchgear if the same application is not already present on the fixed part.

7A Standard diagram

7B Calor Emag diagram.

Electrical characteristics of the contact

Un	Icu	cosφ	T
220 V~	10 A	0.4	–
220 V~	5 A	0.4	–
220 V~	1 A	–	10 ms



8 Isolation lock

Isolation lock for UniGear type ZS1 switchgear and PowerCube modules. It prevents the apparatus from being racked-in if the unit door is open. This lock only works if the door of the switchgear/enclosure is also fitted with the corresponding lock.



9 Locking magnet in the truck

This only allows the withdrawable contactor to be racked into/out of the enclosure with the electromagnet energised and the contactor open. The table below shows the power supply voltages available.

Un	F	Un	F
24 V ~		120 V ~	50 Hz
30 V ~		127 V ~	50 Hz
48 V ~		220 V ~	50 Hz
60 V ~		230 V ~	50 Hz
110 V ~		240 V ~	50 Hz
125 V ~		Un	F
220 V ~		110 V ~	60 Hz
Un	F	120 V ~	60 Hz
24 V ~	50 Hz	127 V ~	60 Hz
48 V ~	50 Hz	220 V ~	60 Hz
60 V ~	50 Hz	230 V ~	60 Hz
110 V ~	50 Hz	240 V ~	60 Hz

10 Lock for different rated currents (only withdrawable versions)

This prevents insertion of the plug-socket and therefore apparatus closing, in a panel provided for a circuit-breaker.

This lock, which is compulsory for UniGear switchgear, requires the same lock provided on the enclosure / switchgear.

SPECIFIC PRODUCT CHARACTERISTICS

Electromagnetic compatibility	18
Resistance to vibrations	18
Tropicalisation	18
Installation of the fixed contactor	18
Altitude	19
Environmental protection programme	19
Use of the fuses according to the load	20

SPECIFIC PRODUCT CHARACTERISTICS

Electromagnetic compatibility

The V-Contact VSC vacuum contactors ensure operation without unwarranted trips when there are interferences caused by electronic apparatus, by atmospheric disturbances or by discharges of electrical type. Moreover they do not produce any interference with electronic apparatus in the vicinity of the apparatus.

The above is in compliance with IEC 60694, 60470, 61000-6-2, 61000-6-4 Standards, as well as with the EEC 89/336 European Directive regarding electromagnetic compatibility (EMC), and the feeders are CE marked to indicate their compliance.

Resistance to vibrations

V-Contact VSC contactors are unaffected by mechanically or electromagnetically generated vibrations.

Tropicalisation

V-Contact vacuum contactors are manufactured in compliance with the prescriptions regarding use in hot-humid-saline climates. All the most important metal parts are treated against corrosive factors corresponding to ambient conditions C in compliance with the UNI 3564-65 Standards. Galvanization is carried out in compliance with the UNI ISO 2081 Standard, classification code Fe/Zn 12, with thickness of 12×10^{-6} m, protected by a layer of conversion mainly consisting of chromates in compliance with the UNI ISO 4520 Standard. These construction characteristics mean that all the V-Contact VSC series apparatus and their accessories comply with climate graph no. 8 of the IEC 721-2-1 and IEC 68-2-2 (Test B: Dry Heat) / IEC 68-2-30 (Test Bd: Damp Heat, cyclic) Standards.

Installation of fixed contactors

The performance of the contactor remains unaltered in the installation positions indicated:

VSC 3

- A) Floor-mounted with horizontal moving contacts.
- B) Wall-mounted with moving contacts at the bottom.
- C) Wall-mounted with moving contacts at the top.

VSC 7 - VSC 12

- D) Floor-mounted with moving contacts at the bottom.
- E) Wall-mounted with horizontal moving contacts and terminals at the bottom.

VSC 3

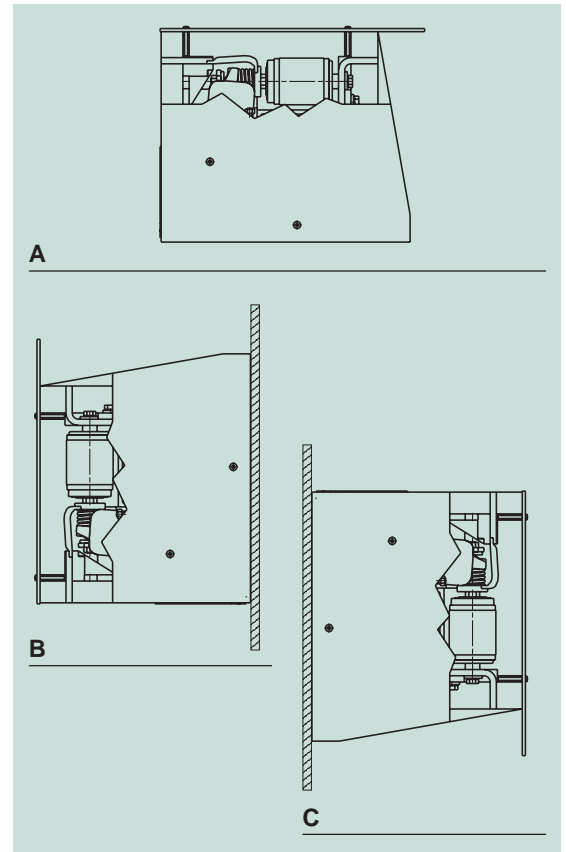

VSC 7 - VSC 12

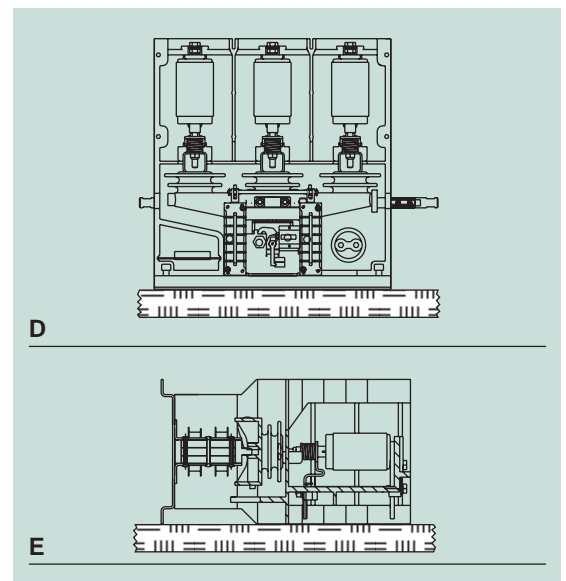

Altitude

It is well-known that the insulating properties of air decrease as the altitude increases.

This phenomenon must always be taken into account during the design stage of insulating parts of equipment which is to be installed over 1000 m above sea level. In this case a correction coefficient must be applied, which can be taken from the graph drawn up according to the indications given in the IEC 694 Standards.

The following example gives a clear interpretation of the indications given above.

Example

- Installation altitude: 2000 m
- Service at a rated voltage of 7 kV
- Withstand voltage at power frequency 20 kV rms
- Impulse withstand voltage 50 kVp
- Ka Factor = 1.13 (see graph).

Taking the above parameters into consideration, the apparatus will have to withstand the following values (under test at zero altitude i.e. at sea level):

- withstand voltage at power frequency equal to:
 $20 \times 1.13 = 22,6 \text{ kVrms}$
- impulse withstand voltage equal to:
 $50 \times 1.13 = 56,5 \text{ kVp}$.

From the above, it can be deduced that for installations at an altitude of 2000 m above sea level, with a service voltage of 7 kV, apparatus with a rated voltage of 12 kV characterized by insulation levels at power frequency of 28 kV rms and with 60/75 kVp impulse withstand voltage must be provided.

Environmental protection programme

The V-Contact VSC contactors are constructed in compliance with the ISO 14000 Standards (Guidelines for environmental management).

The production processes are carried out in compliance with the Standards for environmental protection both in terms of reduction of energy consumption and raw materials and of production of waste. All this is thanks to the environmental management system in the production facility conforming to what is certified by the certifying Organisation.

The minimal environmental impact during the life cycle of the product (LCA - Life Cycle Assessment), is obtained by targeted selection of materials, processes and packing made during the design stage.

The production techniques prepare the products for easy dismantling and easy separation of the components to allow maximum recycling at the end of the useful life cycle of the apparatus.

For this purpose, all the plastic components are marked according to ISO 11469 (2nd ed. 15.05.2000).

When compared with a contactor fitted with a traditional operating mechanism, V-Contact VSC contactors allow an energy saving which prevents emission into the atmosphere of about 7000 kg of carbon dioxide (CO₂).

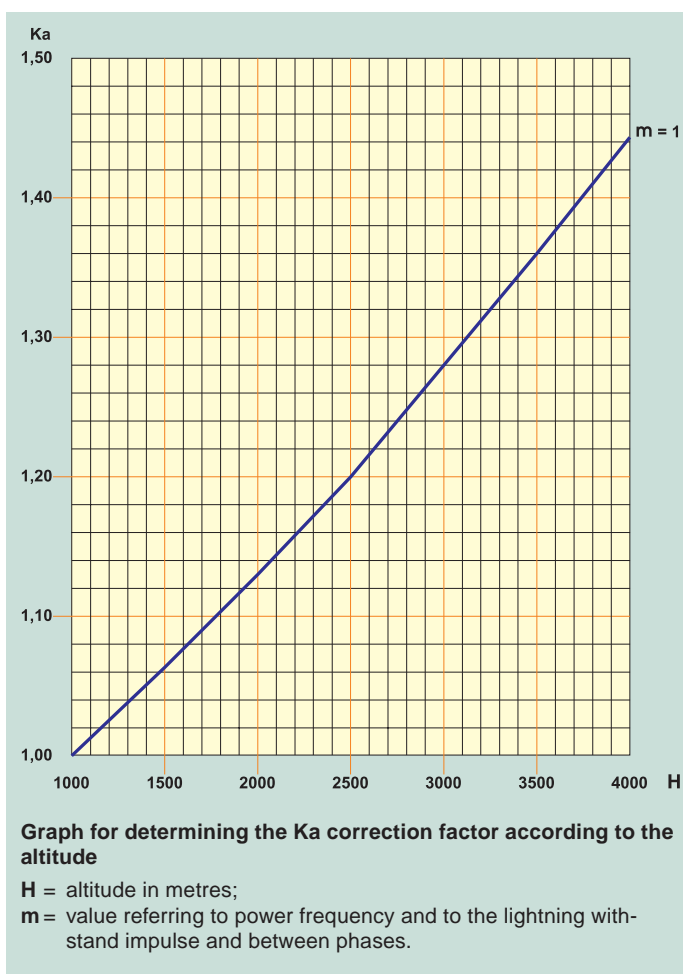

SPECIFIC PRODUCT CHARACTERISTICS

Use of fuses according to the load

Motor control and protection

The motors are supplied in low voltage, normally up to a power of 630 kW. Over the latter power, medium voltage power supply is preferable (from 3 to 12 kV) with the aim of reducing costs and dimensions of all the apparatus which are part of the circuit. The V-Contact can be used for voltages from 2.2 kV up to 12 kV and for motors up to a power of 5000 kW, thanks to the simplicity and sturdiness of the control mechanisms and the long life of the main contacts.

To ensure protection against short-circuit, it is necessary to combine the contactors with appropriate current-limiting fuses. This solution allows the costs of the load-side apparatus (cables, current transformers, busbar and cable anchoring devices, etc.) to be further reduced and to make the user practically independent of any subsequent enlargements of the plant and of the consequent increased in network power.

Procedure for selecting the fuses for motor protection (*)

Selection of the fuses suitable for motor protection must be made by verifying the service conditions. The data to be taken into consideration are:

- power supply voltage
- start-up current
- duration of start-up
- number of start-ups/hour
- current at full motor load
- short-circuit current of the installation.

Searching for trip coordination with the other protection releases in order to adequately protect the contactor, current transformers, cables, the motor itself and all the other apparatus present in the circuit, which could be damaged by prolonged overloads or by a specific let-through energy (I²t) higher than the one which can be withstood, also figures among the selection criteria.

Protection against short-circuit is carried out by the fuses, always selected with a rated current higher than that of the motor to prevent their intervention on start-up. This method of selection does not, however, allow their use as protection against repeated overloads - a function already not guaranteed by them, especially with current values included up to the end of the initial asymptotic stretch of the characteristic curve.

A release with inverse or independent time is therefore always needed for protection against

Fig. A - Fuse selection curves for motor start-up. ABB CMF type fuses.

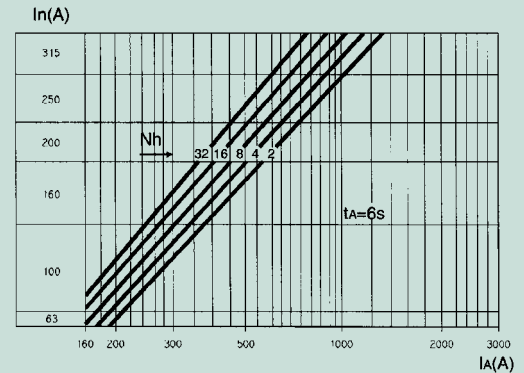

overloads. This protection must be coordinated with the one carried out by the fuse, working so that the release and fuse curves intersect at a point to allow the following:

- 1) Motor protection against overcurrents due to overloads, single-phase running, blocked rotor and repeated start-ups. Protection entrusted to an indirect relay with inverse or definite time delay trip which acts on the contactor.
- 2) Protection of the circuit against fault currents, between phases and towards earth, of low value, entrusted to a release with inverse or definite time delay trip, which must only intervene for the short-circuit values which can be interrupted by the contactor.
- 3) Protection of the circuit against fault currents higher than the breaking capacity of the contactor up to the maximum fault withstand current. Protection entrusted to the fuse.

To verify the service conditions, proceed as follows:

- **Rated voltage U_n .** This must be equal to or higher than the service voltage of the installation.

Check that the level of insulation of the network is higher than the switching overvoltage value generated by the fuses, which for the fuses used by ABB is widely below the limit fixed by the IEC 282-1 Standards.

(*) The selection criterion indicated refers to ABB type CMF fuses.

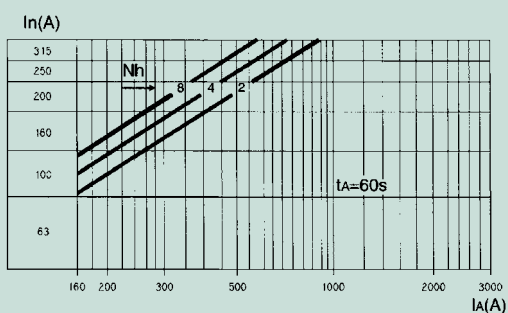
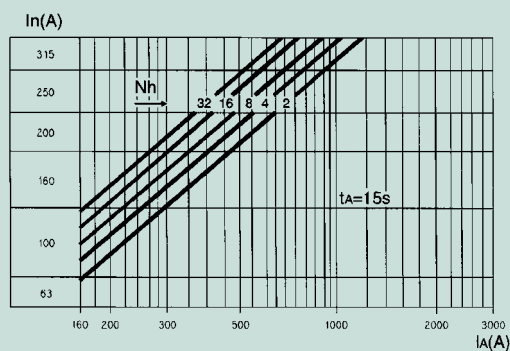

I_n = rated current of the fuse
 I_A = motor start-up current

N_h = number of motor start-ups in one hour
 t_A = maximum motor start-up time

Fig. B - Curve of fuse blowing times and table for selection of factor K. ABB CMF type fuses.

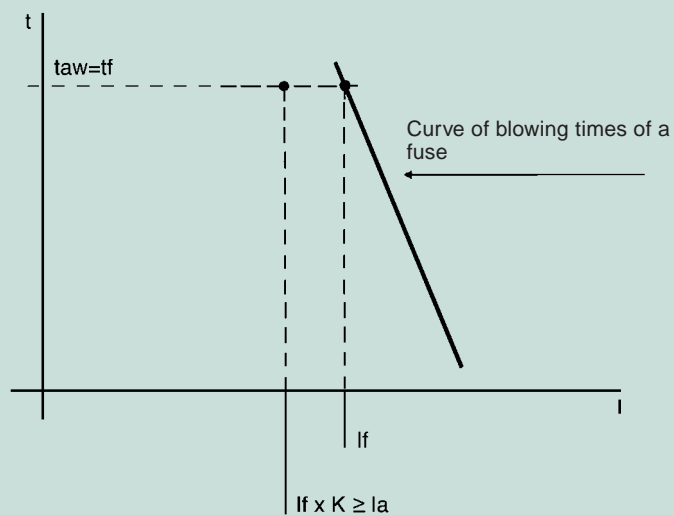
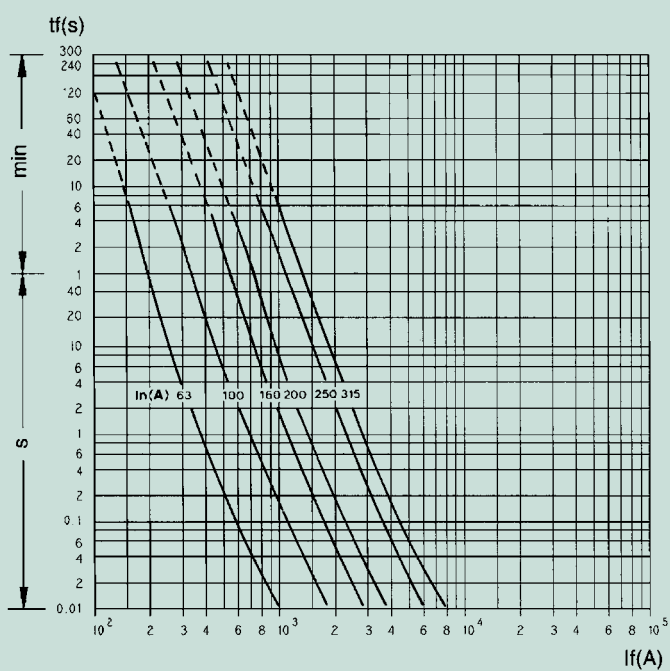

Table for selection of factor K

U_n [kV]	I_n [A]					
3.6	63	100	160	200	250	315
7.2	63	100	160	200	250	315
12	63	100	160	200	-	-
K	0.75	0.75	0.7	0.7	0.6	0.6

SPECIFIC PRODUCT CHARACTERISTICS

- **Rated current I_n .** This must be selected by consulting the diagrams indicated in fig. A which refer to the case of starting at fairly even time intervals, except for the first two start-ups of each hourly cycle which can take place in immediate succession.

Each diagram refers to a different starting time: 6 s - 15 s - 60 s, respectively.

In the case of start-ups close together, it must be checked that the starting current does not exceed the value of $I_f \times K$, where I_f is the fuse blowing current in correspondence with the starting time of the motor, and K is a minor factor of the unit, a function of the I_n of the fuse and which can be taken from the table in figure B.

- **Full load motor current.** The rated current of the fuse must be of a value equal to or higher than 1.33 times the rated current value of full motor load.
This condition is, in any case, always obtained for motors started at full voltage for which the procedure described for selection of the rated fuse current necessarily imposes values which are always higher than $1.33 I_n$.
- **Short-circuit current.** The short-circuit current limiting curves in fig. C allow the short-circuit current limitation on the load side of the fuses involved in the fault to be appreciated. And this implies smaller sizing of the load side apparatus.

Example of coordination for overload of a fuse-relay with inverse time delay trip

Motor characteristics:

P_n	=	1000 kW
U_n	=	6 kV
I_{start}	≈	$5 I_n = 650 \text{ A}$
T_{start}	=	6 s
No. hourly operations	=	16.

In the curve with starting time of 6 s in fig. A, in correspondence with the 650 A starting current value, the straight line, traced for 16 hourly start-ups, intersects in the range of the 250 A fuse.

In the fuse blowing time curve, it can be noted that the 250 A fuse blows in 6 s (starting time) when it is passed through by a current of 1800 A.

In the table in fig. B, the K coefficient for the 250 A size is 0.6, from which the value $I_f \times K = 1080 \text{ A}$ is taken, which is higher than the start-up current (650 A), so use of the 250 A fuse is also legitimate in respect of this condition, which regards the possibility of start-ups close together.

By observing the blowing curve of the 250 A fuse, the need to use a relay with inverse time delay trip, or a relay with definite time delay trip for protection against overloads can be noted.

It must be remembered that prolonged overheating, above the temperature foreseen for the class of insulating materials, is harmful and strongly prejudices the life of electric machines.

Fig. D shows the graph relative to the motor considered in the example.

Fig. C - Short-circuit current limitation curves. ABB CMF type fuses.

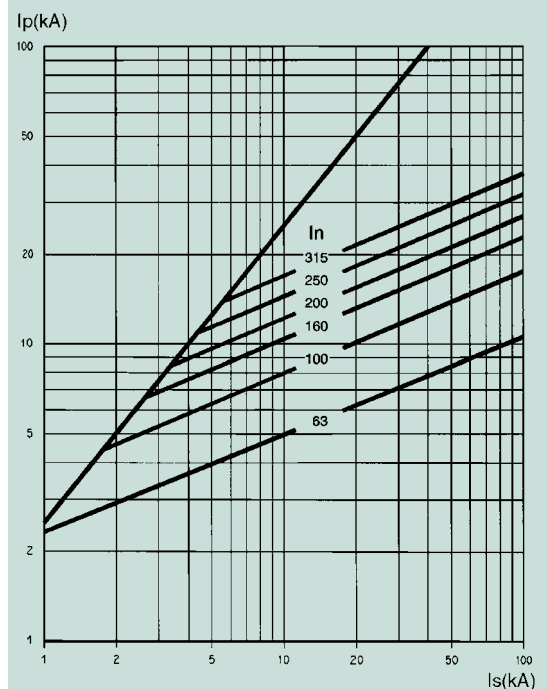

I_s = prospective short-circuit symmetrical current
 I_p = current limited by the fuse (peak value)

Motor starting

Motor starting poses the problem of the high current consumption on inrush.

In most cases, since these are asynchronous motors, the start-up current can take on the following values:

- asynchronous with simple squirrel cage 4.5 ... 5.5 I_n
- asynchronous with double squirrel cage 5 ... 7 I_n
- asynchronous with wound motor: low values, dependent on selection of the starting resistances.

This current cannot be available if the short-circuit power of the network is not sufficiently high and, in any case, can give rise to a drop in voltage for the whole duration of starting, which cannot be tolerated, from the loads derived from the network itself. Normally a voltage drop between 15 and 20% is considered acceptable except for verification needed in the case of special users.

The full voltage start-up condition can be checked analytically and turns out to be possible in most cases.

If the calculations show that the start-up power causes a voltage drop higher than the admissible one, starting with reduced voltage must be used, with consequent reduction in the start-up current. For this purpose, starting with a step-down autotransformer is generally used.

For large motors it may be more convenient to use a transformer, whose sizing can be a little higher than the power required by the motor, dedicated exclusively to the machine: start-up therefore takes place with reduced voltage (strong voltage drop on the secondary winding of the transformer) without the rest of the plant being affected.

Fig. D - Graph showing the coordination between 250 A fuse and relay with inverse time delay trip.

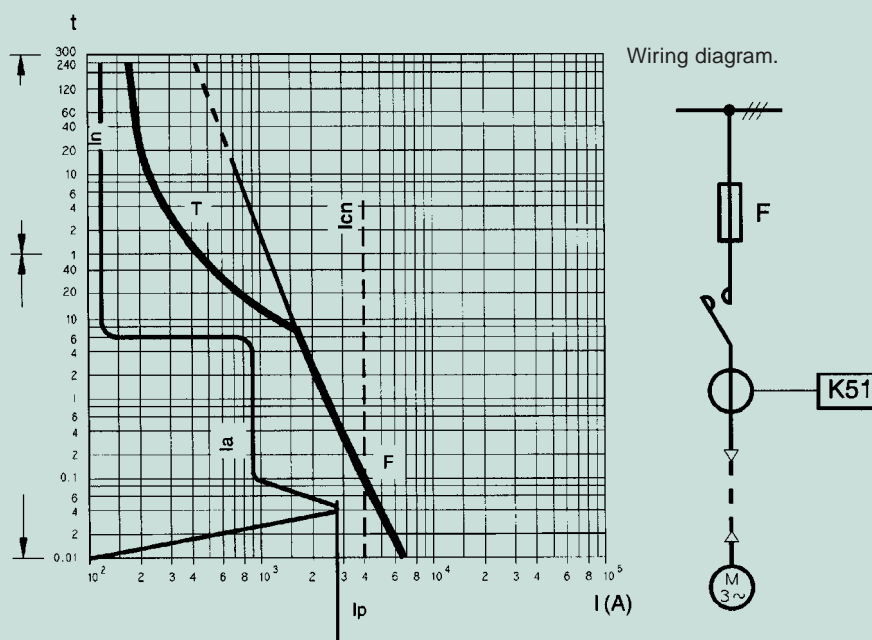

I_{cn} = maximum short-circuit current in amperes that the contactor can interrupt

I_a = motor start-up current in amperes

I_n = motor rated current in amperes

t = time in seconds

I = current in amperes

F = time-current characteristic of the 250 A fuse

T = inverse time characteristics of the indirect relay for protection against overloads (K51)

I_p = peak value of the motor connection current