

DATA SHEET

GEN series G070A Torque/RPM adapter

SPECIAL FEATURES

- Connect up to two torque transducers
- Connect to T12/T40B using standard cables
- RS422 differential input signals for highest immunity
- Connect to GEN DAQ mainframe using standard cable
- Dual signal output for dual use with test cell control system
- Low latency outputs
- Power T12/T40B from adapter (Power supply not included)
- Connect to binary, frequency or ABz based sensors using RS422 signals



TORQUE/RPM ADAPTER - FUNCTIONS AND BENEFITS

The Torque/RPM adapter enables the connection of HBM's T12, T40B or similar torque transducers to GEN DAQ mainframes. The use of differential signals improves the immunity to external disturbance especially when using long cables in electrically noisy environments. For easy connectivity of transducers the adapter can optionally route power over the transducer cables, this avoids the need of separate power cables. This power input is separately connected to the adapter per transducer. Whenever a test cell control system requires parallel access to the torque and/or speed signals, the adapter reconditions the incoming signals and outputs all input signals as RS422 differential signals. All outputs come with low latency to support real-time safety monitoring applications.

Each of the torque and speed inputs are directly connected to the GEN DAQ high resolution Timer/Counter channels. The speed input supports direction and reference pulse to enable rotational angle measurement. The torque input supports shunt to optimize accuracy.

In addition to HBM torque sensors, the adapter allows use with any binary, frequency or ABz based sensor. E.g. for more accurate/higher resolution rotational speed and angle measurement, standard industrial incremental encoders with RS422 signals can be used simultaneously with the HBM torque transducer.

All event inputs provided by the GEN DAQ mainframe that are not used to connect to the torque and speed signals are rewired to a pin compatible event I/O connector.

Torque/RPM Adapter Block Diagram

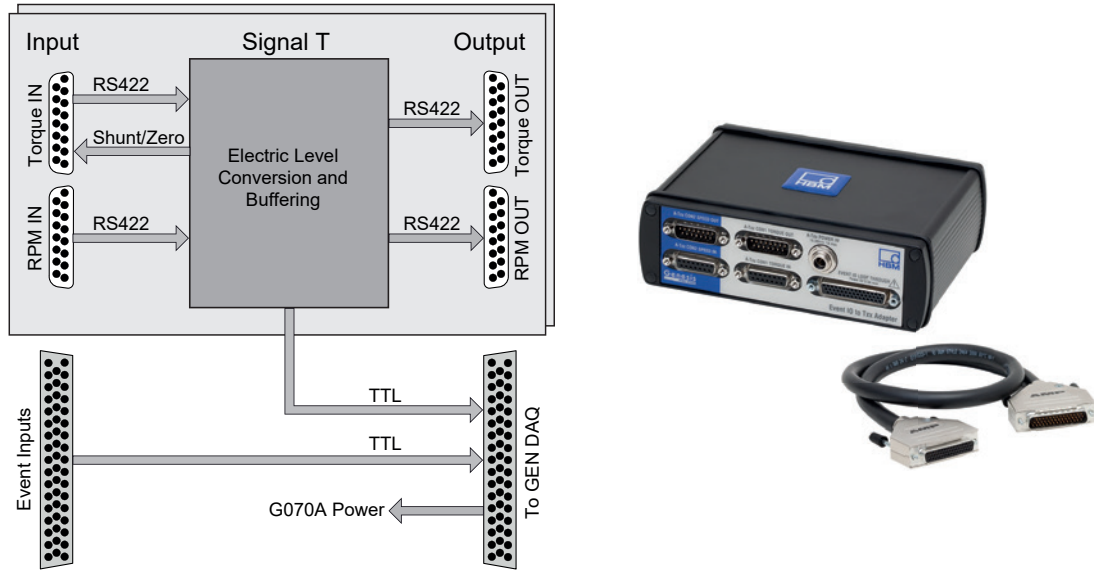

Figure 1: Block diagram adapter

G070A: Torque/RPM Adapter (Option, to be ordered separately)	
Connects a T12, T40 or similar torque transducer to GEN3i, GEN3t, GEN7i and GEN7tA Digital Event/Timer/Counter connector	
Torque sensor connection	
Number of torque sensors	2
Torque interface support	Torque and shunt (A-Txx CON1 Torque IN & B-Txx CON1 Torque IN)
Speed interface support	RPM, direction and reference (A-Txx CON2 Speed IN & B-Txx CON2 Speed IN)
Inputs	
Signal type	Differential RS422
Maximum nondestructive input voltage	- 4 V to + 8 V input to ground - 12 V to + 12 V -input to +input (differential input)
Signal termination	100 Ω
Propagation delay (Input to GEN DAQ)	16 ns (typical)
Input buffers	AM26LV32C
Torque sensor loop through	
Number of torque sensors	2
Torque interface output	Torque (A-Txx CON1 Torque OUT & B-Txx CON1 Torque OUT)
Speed interface output	RPM, Direction and Reference (A-Txx CON2 Speed OUT & B-Txx CON2 Speed OUT)
Outputs	
Output type	Differential RS422, electronic retransmitted from input signals
Output voltage	- 0.3 V to + 6 V
Output current	\pm 25 mA
Propagation delay (Input to Output)	23 ns (typical)
Maximum signal frequency (Input to Output)	30 MHz
Output drivers	AM26C31C
Connectors	
Digital Event/Timer/Counter	HD22 sub-D 44 pin male (connecting cable included)
Loop through event input	44 pin, female D-type connector, AMP HD-22 series (Tyco/TE Connectivity: 5748482-5)
Loop through cable connector type	44 pin, male D-type connector, HDP-22 series (Tyco/TE Connectivity: 1658680-1), to be ordered separately
Torque, Speed/RPM interface IN	15 pin, female sub-D type (matches 1-KAB149-6 and 1-KAB163-6)
Torque, Speed/RPM interface OUT	15 pin, male sub-D type
Torque power input	Switchcraft L712A Matching cable connector Switchcraft 761KS17 (LD-024-1000911). Two cable connectors included
Cables	
Torque/RPM adapter to GEN DAQ mainframe	1.5 m (4.92 ft), included with Torque/RPM adapter
Torque sensor to Txx Torque IN	1-KAB149-6 (other lengths available), to be ordered separately
Torque sensor to Txx Speed IN	1-KAB163-6 (other lengths available), to be ordered separately
Power	
Adapter	Power by GEN DAQ mainframe
Torque sensors	Requires separate power supply Check the manual of the used torque sensor to select proper power supply

Torque/RPM Adapter Connector Layout



Figure 2: G070A front view

Front side connectors

Sensor A input	Torque and Speed
Sensor A output	Torque and Speed
Sensor A power input	Optional sensor A power, supplied on Torque input connector
Event input	All remaining events not used for sensor A and B torque and RPM measurements



Figure 3: G070A back view

Back side connectors

Sensor B input	Torque and Speed
Sensor B output	Torque and Speed
Sensor B power input	Optional sensor B power, supplied on Torque input connector
Digital Event/Timer/Counter output	Connections to GEN DAQ mainframe, includes power from GEN DAQ to G070A

Torque Sensor Connector Pin Assignment

Pin 5 : Supply voltage ground (not connected to signal ground)
 Pin 6 : Supply voltage 18 V to 30 V
 Pin 8: Ground
 Pin 12: + Torque Signal
 Pin 13: - Torque Signal
 Pin 14: Shunt Signal trigger 5 V to 30 V

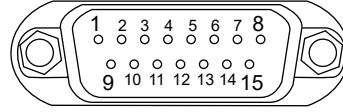

Shielding connected to connector housing
 All other pins not connected

Figure 4: Torque IN and OUT connector pinning

Pin 2: - Reference Signal
 Pin 3: + Reference Signal
 Pin 8: Signal ground
 Pin 12: + Rotational Speed 0° Signal
 Pin 13: - Rotational Speed 0° Signal
 Pin 14: - Rotational Speed 90° Signal
 Pin 15: + Rotational Speed 90° Signal

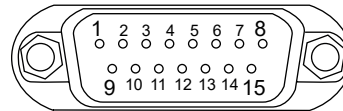

Shielding connected to connector housing
 All other pins not connected

Figure 5: Speed IN and OUT connector pinning

Torque Sensor Power Connector Assignment

Power connector	Switchcraft L712A
Cable connector	Switchcraft 761KS17, included in shipment
Connector pinning	
Outer shield	Supply voltage ground
Inner pin	Supply voltage (18 V to 30 V)

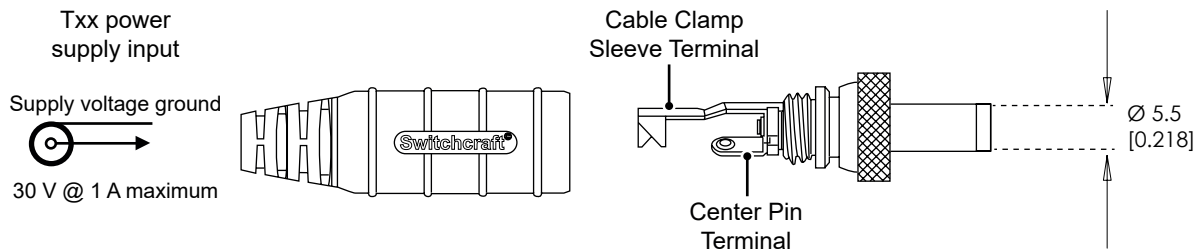

Figure 6: Cable connector details

Loop through Connector Pin Assignment



PIN 1 - Not connected	PIN 16 - Event Input 4B	PIN 31 - Event Input 15B
PIN 2 - Not connected	PIN 17 - Event Input 5B	PIN 32 - Event Input 16B
PIN 3 - Not connected	PIN 18 - Event Input 6B	PIN 33 - Event Input 13A
PIN 4 - Event Input 4A	PIN 19 - Event Input 7B	PIN 34 - Event Input 14A
PIN 5 - Event Input 5A	PIN 20 - Event Input 8B	PIN 35 - Event Input 15A
PIN 6 - Event Input 6A	PIN 21 - Event Input 9B	PIN 36 - Event Input 16A
PIN 7 - Event Input 7A	PIN 22 - Not connected	PIN 37 - Event Output 2B
PIN 8 - Event Input 8A	PIN 23 - Not connected	PIN 38 - Event Output 1B
PIN 9 - Event Input 9A	PIN 24 - Not connected	PIN 39 - Event Output 2A
PIN 10 - Not connected	PIN 25 - Event Input 13B	PIN 40 - Event Output 1A
PIN 11 - Not connected	PIN 26 - Event Input 14B	PIN 41 - Ground
PIN 12 - Not connected	PIN 27 - Ground	PIN 42 - Ground
PIN 13 - Not connected	PIN 28 - Ground	PIN 43 - +5 V Power output
PIN 14 - Not connected	PIN 29 - Ground	PIN 44 - +5 V Power output
PIN 15 - Not connected	PIN 30 - Ground	

Figure 7: Pin diagram for loop through connector

Torque/RPM Adapter Wiring Diagram

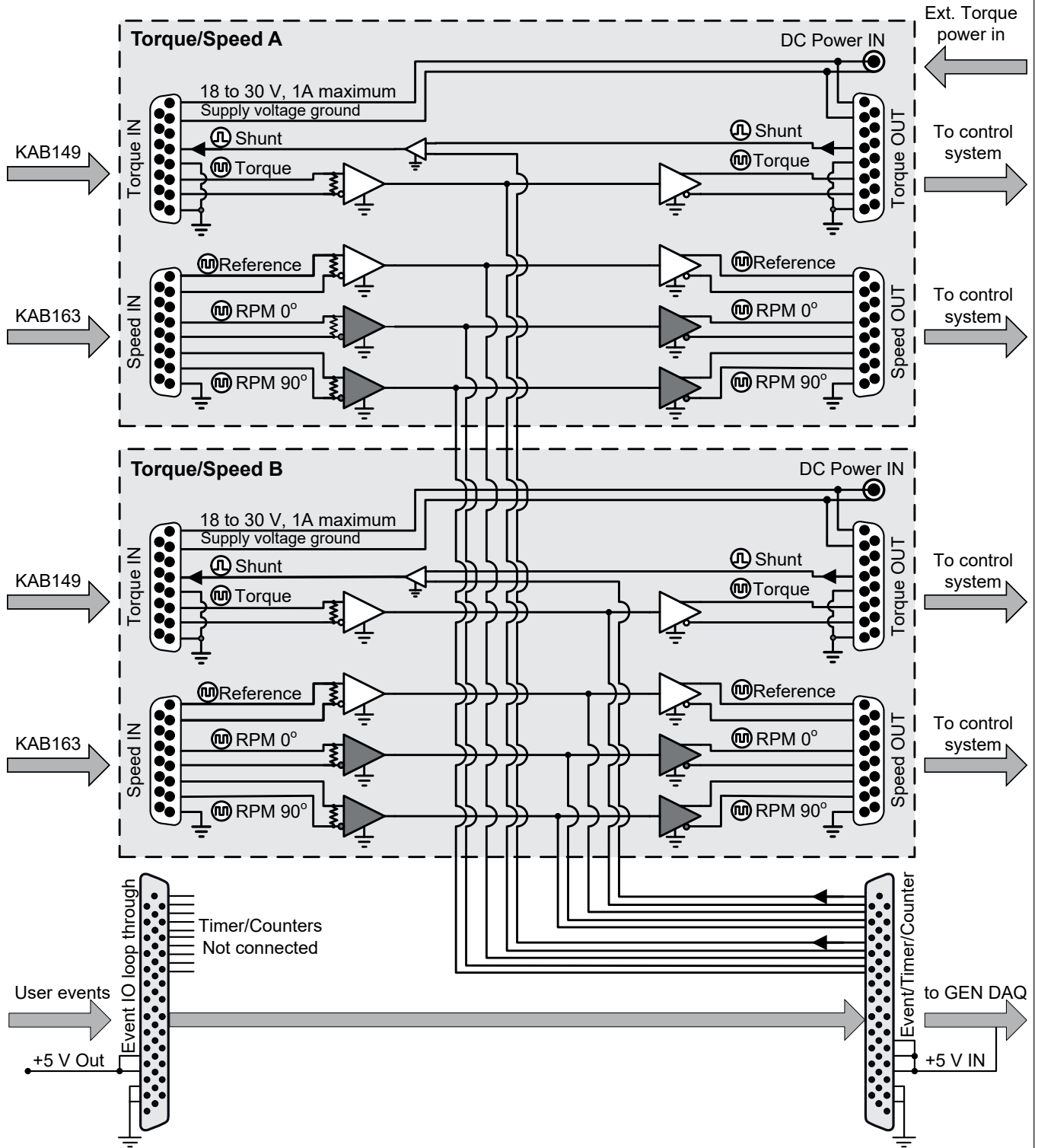

Figure 8: Block Diagram Torque/RPM Adapter

Application Examples

Example 1: Connection of a single torque transducer with torque and speed to GEN DAQ input A using the G070A adapter; Torque transducer powered directly; no control system output.

Note: GEN series connection supported for GEN3i/GEN3iA, GEN3t, GEN7i/GEN7iA, GEN7tA/GEN7tB (shown) or GEN17tA/GEN17tB.

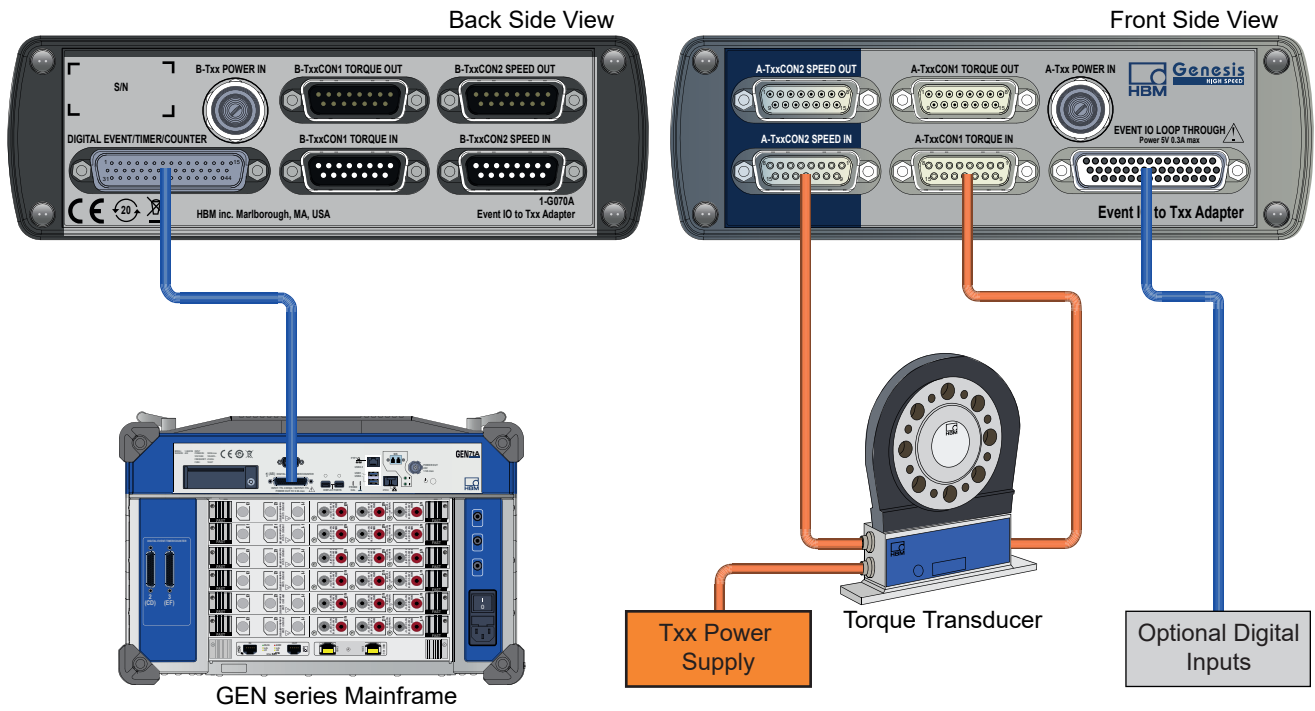

Figure 9: External powered torque transducer connected to GEN DAQ

Application Examples

Example 2: Connection of a single torque transducer with torque and speed to GEN DAQ (input A); Torque transducer powered using G070A; torque and speed output to control system

Note: GEN series connection supported for GEN3i/GEN3iA, GEN3t, GEN7i/GEN7iA, GEN7tA/GEN7tB (shown) or GEN17tA/GEN17tB.

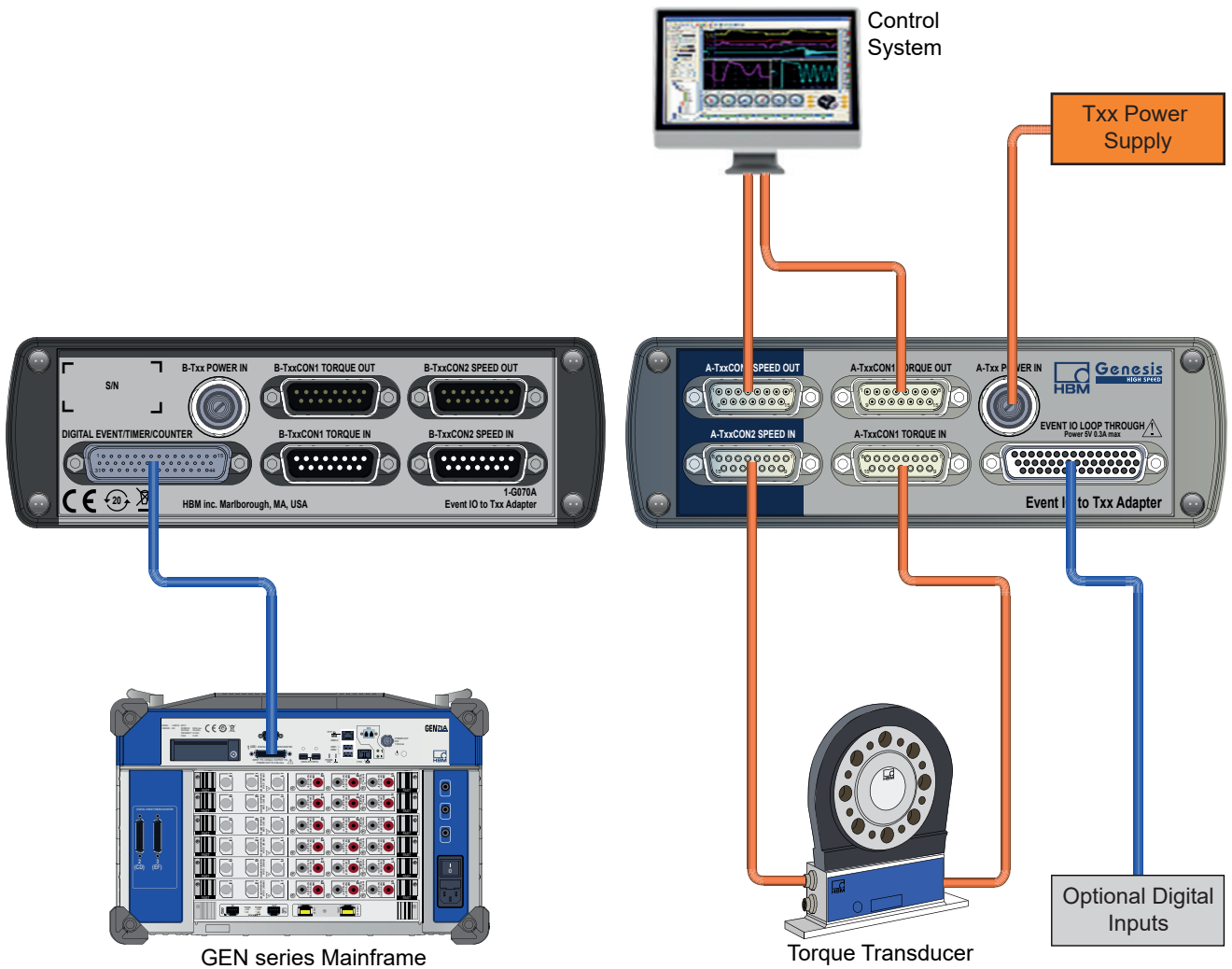

Figure 10: G070A powered torque transducer connected to GEN DAQ and control system

Application Examples

Example 3: Connection of two torque transducers connecting torque and speed to GEN DAQ (input A and B); both torque transducers powered using G070A; torque and speed of transducer A output to control system.

Note: GEN series connection supported for GEN3i/GEN3iA, GEN3t, GEN7i/GEN7iA, GEN7tA/GEN7tB (shown) or GEN17tA/GEN17tB.

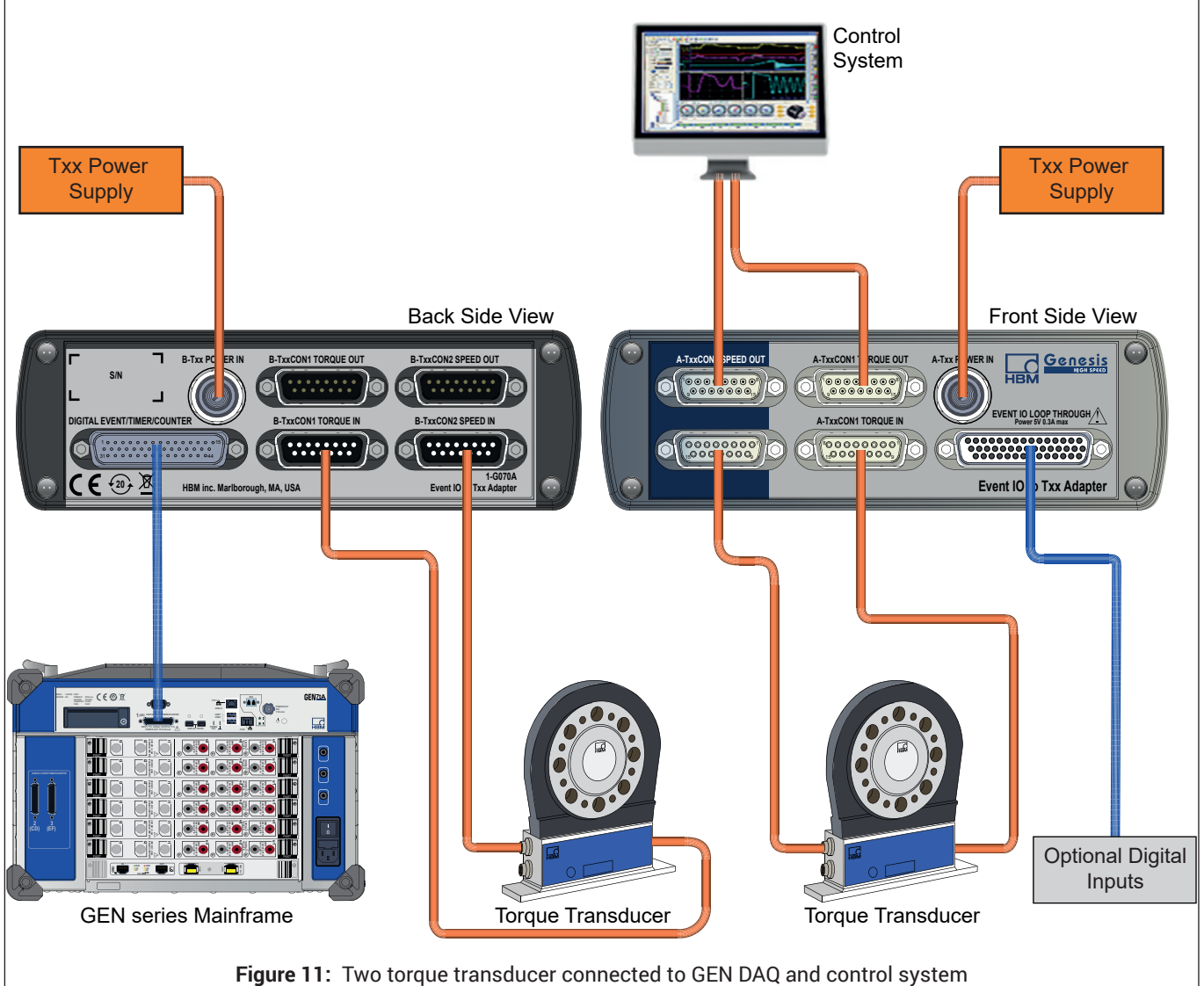

Figure 11: Two torque transducer connected to GEN DAQ and control system

Application Examples

Example 4: Connection of a single torque transducer with torque only to GEN DAQ (input A); torque transducer powered using G070A; separate incremental encoder used for speed, encoder directly powered; torque and speed output to control system.

Note: GEN series connection supported for GEN3i/GEN3iA, GEN3t, GEN7i/GEN7iA, GEN7tA/GEN7tB (shown) or GEN17tA/GEN17tB.

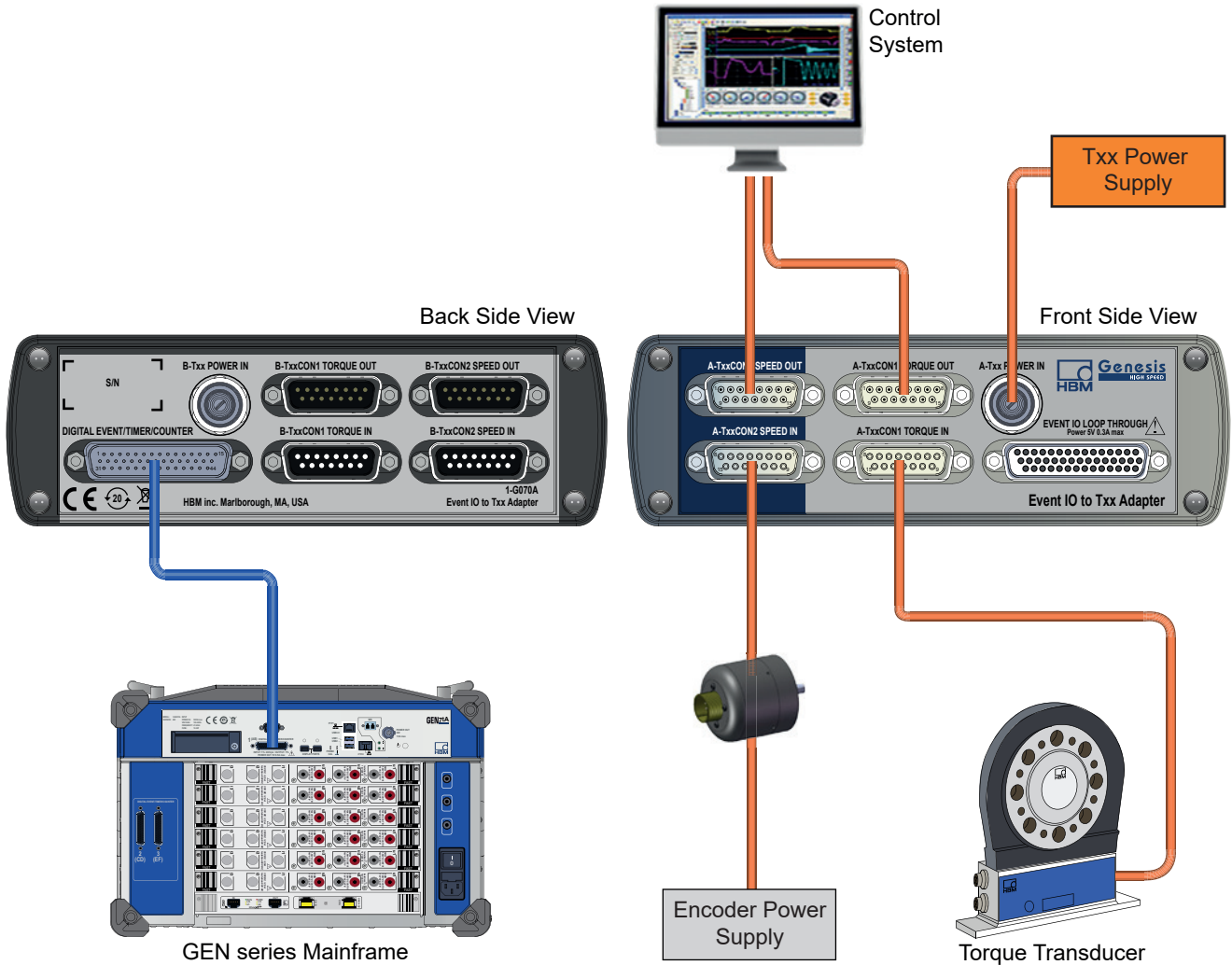

Figure 12: Torque transducer and speed encoder connected to GEN DAQ and control system

Physical, Weight and Dimensions

Weight

Mainframe	0.75 kg (1.65 lb)
-----------	-------------------

Dimensions

Height	55 mm (2.2")
--------	--------------

Width	172 mm (6.8")
-------	---------------

Depth	124 mm (4.9")
-------	---------------

Grounding

Uses shield for GEN DAQ cable connection

Casing

Aluminum

Accessories

Cable to connect adapter to GEN DAQ mainframe event connector, included with Torque/RPM adapter

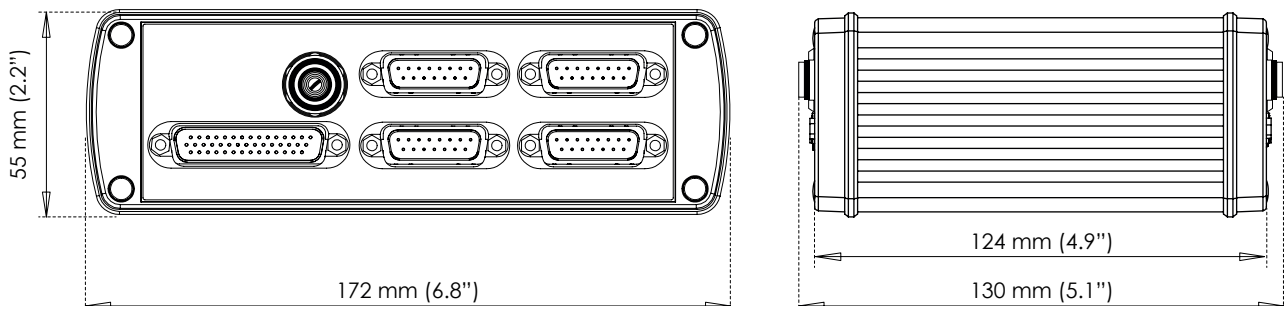



Figure 13: G070A dimensions

Environmental Specifications	
Temperature Range	
Operational	0 °C to +40 °C (+32 °F to +104 °F)
Non-operational (Storage)	-25 °C to +70 °C (-13 °F to +158 °F)
Relative humidity	0% to 80%; non-condensing; operational
Protection class	IP20
Altitude	Maximum 2000 m (6562 ft) above sea level; operational
Shock: IEC 60068-2-27	
Operational	Half-sine 10 g/11 ms; 3-axis, 1000 shocks in positive and negative direction
Non-operational	Half-sine 25 g/6 ms; 3-axis, 3 shocks in positive and negative direction
Vibration: IEC 60068-2-64	
Operational	1 g RMS, ½ h; 3-axis, random 5 to 500 Hz
Non-operational	2 g RMS, 1 h; 3-axis, random 5 to 500 Hz
Operational Environmental Tests	
Cold test IEC60068-2-1 Test Ad	-5 °C (+23 °F) for 2 hours
Dry heat test IEC-60068-2-2 Test Bd	+40 °C (+104 °F) for 2 hours
Damp heat test IEC60068-2-3 Test Ca	+40 °C (+104 °F), humidity > 93% RH for 4 days
Non-Operational (Storage) Environmental Tests	
Cold test IEC-60068-2-1 Test Ab	-25 °C (-13 °F) for 72 hours
Dry heat test IEC-60068-2-2 Test Bb	+70 °C (+158 °F) humidity < 50% RH for 96 hours
Change of temperature test IEC60068-2-14 Test Na	-25 °C to +70 °C (-13 °F to +158 °F) 5 cycles, rate 2 to 3 minutes, dwell time 3 hours
Damp heat cyclic test IEC60068-2-30 Test Db variant 1	+25 °C/+40 °C (+77 °F/+104 °F), humidity >95/90% RH 6 cycles, cycle duration 24 hours

Harmonized Standards for CE and UKCA Compliance, According to the Following Directives ⁽¹⁾	
Low Voltage Directive (LVD): 2014/35/EU	
Electromagnetic Compatibility Directive (EMC): 2014/30/EU	
Electrical Safety	
EN 61010-1 (2017)	Safety requirements for electrical equipment for measurement, control, and laboratory use - General requirements
EN 61010-2-030 (2017)	Particular requirements for testing and measuring circuits
Electromagnetic Compatibility	
EN 61326-1 (2013)	Electrical equipment for measurement, control and laboratory use - EMC requirements - Part 1: General requirements
Emission	
EN 55011	Industrial, scientific and medical equipment - Radio-frequency disturbance characteristics Conducted disturbance: class B; Radiated disturbance: class A
EN 61000-3-2	Limits for harmonic current emissions: class D
EN 61000-3-3	Limitation of voltage changes, voltage fluctuations and flicker in public low voltage supply systems
Immunity	
EN 61000-4-2	Electrostatic discharge immunity test (ESD); contact discharge ± 4 kV/air discharge ± 8 kV: performance criteria B
EN 61000-4-3	Radiated, radio-frequency, electromagnetic field immunity test; 80 MHz to 2.7 GHz using 10 V/m, 1000 Hz AM: performance criteria A
EN 61000-4-4	Electrical fast transient/burst immunity test Mains ± 2 kV using coupling network. Channel ± 2 kV using capacitive clamp: performance criteria B
EN 61000-4-5	Surge immunity test Mains ± 0.5 kV/ ± 1 kV Line-Line and ± 0.5 kV/ ± 1 kV/ ± 2 kV Line-earth Channel ± 0.5 kV/ ± 1 kV using coupling network: performance criteria B
EN 61000-4-6	Immunity to conducted disturbances, induced by radio-frequency fields 150 kHz to 80 MHz, 1000 Hz AM; 10 V RMS @ mains, 3 V RMS @ channel, both using clamp: performance criteria A
EN 61000-4-11	Voltage dips, short interruptions and voltage variations immunity tests Dips: performance criteria A; Interruptions: performance criteria C

- (1)  The manufacturer declares on its sole responsibility that the product is in conformity with the essential requirements of the applicable UK legislation and that the relevant conformity assessment procedures have been fulfilled.

Manufacturer:

Hottinger Brüel & Kjaer GmbH
Im Tiefen See 45
64293 Darmstadt
Germany

Importer:

Hottinger Bruel & Kjaer UK Ltd.
Technology Centre Advanced Manufacturing Park
Brunel Way Catcliffe
Rotherham
South Yorkshire
S60 5WG
United Kingdom

Ordering Information⁽¹⁾

Article	Description	Order No.
Torque/RPM adapter	 <p data-bbox="799 232 1241 535">Converts the differential signaling used by HBM torque transducers to TTL signal levels used by the Timer/Counter A and B available on the Digital Event/Timer/Counter connector of GEN DAQ mainframes. Both Torque and Speed are interfaced separately for 2 torque sensors. Event output connected to Shunt control. All remaining event TTL signals available on output connector. Comes with 1.5 m (4.92 ft) cable to connect adapter to the mainframe. Torque transducer cables not included.</p>	1-G070A

(1) All GEN series systems are intended for exclusive professional and industrial use.

Custom Modification

Article	Description	Order No.
Speed input modified to TTL	 <p data-bbox="799 766 1209 880">A standard G070A must be sent to custom systems. Custom system will then convert the speed input from standard RS422 to TTL levels.</p>	SYS706032

(1) Contact custom systems at: customsystems@hbkworl.com

Hottinger Brüel & Kjaer GmbH

Im Tiefen See 45 · 64293 Darmstadt · Germany
Tel. +49 6151 803-0 · Fax +49 6151 803-9100
www.hbkworld.com · info@hbkworl.com

Subject to modifications. All product descriptions are for general information only.
They are not to be understood as a guarantee of quality or durability.