

# 190501 Velomitor CT Transducer

## Datasheet

Cordant™

141636 Rev. AF



## Description

The Velomitor CT Velocity Transducer is a low-frequency version of our standard Velomitor Piezo-velocity Sensor. Its design specifically measures casing vibration velocity on cooling tower and air-cooled heat-exchanger fan assemblies that operate at or above 90 rpm (100 to 300 rpm typical).

The Velomitor CT Transducer can measure vibration amplitudes at these frequencies as well as the vibration frequencies generated by the fan motor and speed reducer.



Most common machine malfunctions (unbalance, misalignment, etc.) occur on the rotor and originate as an increase (or at least a change) in rotor vibration. For any individual casing measurement to be effective for overall machine protection, the system must continually transmit a significant amount of rotor vibration to the machine casing, or mounting location of the transducer.

In addition, be careful to install the accelerometer transducer on the bearing housing or machine casing. Improper installation may decrease the transducer amplitude and frequency response and/or generate false signals that do not represent actual vibration. Refer to the appropriate instruction manuals and Application Notes.

Upon request, Bently Nevada provides engineering services that can identify the appropriate machine housing measurements and installation assistance if needed.



Baker Hughes 

## Specifications

Parameters are specified from +20°C to +30°C (+68°F to +86°F) and 100 Hz unless otherwise indicated.



Operating the transducer outside the specified limits will result in false readings or loss of machine monitoring.

## Electrical

|                            |                                                                                                                                                                                                                                                                               |
|----------------------------|-------------------------------------------------------------------------------------------------------------------------------------------------------------------------------------------------------------------------------------------------------------------------------|
| Sensitivity                | 3.94 mV/mm/s (100 mV/in/s) ±5%.                                                                                                                                                                                                                                               |
| Frequency Response         | 3.0 Hz to 900 Hz (180 to 54,000 cpm) ±1.0 dB                                                                                                                                                                                                                                  |
|                            | 1.5 Hz to 1.0 kHz (90 to 60,000 cpm) ±3.0 dB                                                                                                                                                                                                                                  |
| Temperature Sensitivity    | -8% to +5% typical over the operating temperature range.                                                                                                                                                                                                                      |
| Velocity Range             | 63.5 mm/s pk (2.5 in/s pk) (see <a href="#">Figure 4: Operating Range for Metric Units on page 13</a> and <a href="#">Figure 5: Operating Range for English Units on page 14</a> ). Vibration components in excess of 10g pk above 1 kHz can significantly reduce this range. |
| Transverse Response        | Less than 5% of the axial sensitivity.                                                                                                                                                                                                                                        |
| Amplitude Linearity        | ±2% to 63.5 mm/s pk (2.5 in/s pk)                                                                                                                                                                                                                                             |
| Mounted Resonant Frequency | 9 kHz, minimum (stud mounted, except quick disconnect)                                                                                                                                                                                                                        |
| Output Bias Voltage        | 10.1 Vdc ± 1.0 Vdc, Pin A referenced to Pin B                                                                                                                                                                                                                                 |

|                                         |                                                                                                                                   |
|-----------------------------------------|-----------------------------------------------------------------------------------------------------------------------------------|
| Dynamic Output Impedance                | < 400 Ω typical                                                                                                                   |
| Broadband Noise Floor (1.5 Hz to 1 kHz) | 0.229 mm/s (0.009 in/s) pk.<br>For more information, see <a href="#">Figure 6: Typical Low Frequency Noise Floor on page 15</a> . |
| Base Strain Sensitivity                 | 0.43 mm/s/μstrain (0.017 in/s/μstrain).                                                                                           |
| Grounding                               | Internal electronics are isolated from case.                                                                                      |
| Maximum Cable Length                    | 305 m (1,000 ft.) of cable (part number 02173006) with no degradation of signal.                                                  |



Maximum continuous length of cable available is 91.44 m (300 ft). If longer lengths are required they must be spliced or have a connector installed on them.

## Environmental Limits

|                               |                                                             |
|-------------------------------|-------------------------------------------------------------|
| Operating Temperature         | -40°C to +85°C (-40°F to +185°F).                           |
| Storage Temperature           | -40°C to +100°C (-40°F to +212°F).                          |
| Shock Limit                   | 5000 g pk, maximum.                                         |
| Humidity Limit                | 100% condensing, non-submerged.                             |
| Magnetic Field Susceptibility | < 0.0068 mm/s/gauss (0.268 mil/s/gauss) @ 50 gauss, 50-60Hz |

## Physical

|                          |                                                                                                                                                                               |
|--------------------------|-------------------------------------------------------------------------------------------------------------------------------------------------------------------------------|
| Weight                   | <297 g (10.5 oz.), typical.                                                                                                                                                   |
| Mounting Surface         | 33 mm diameter (1.3 in diameter).                                                                                                                                             |
| Height                   | 82 mm (3.2 in).                                                                                                                                                               |
| Case Material            | 316L stainless steel                                                                                                                                                          |
| Connector                | 2-pin 316L stainless steel MIL-C-5015, top.                                                                                                                                   |
| Mounting Torque          | 4.5 N-m $\pm$ 0.6 N-m (40 in-lbf $\pm$ 5 in-lbf).                                                                                                                             |
| Polarity                 | Pin A goes positive with respect to Pin B when velocity is from base to top of the transducer.                                                                                |
| Mounting Angle           | Any orientation.                                                                                                                                                              |
| Recommended Cable Length | 219 m (720 ft)<br>Assuming max vibration of 4 in/s, frequency 1 kHz, and cable capacitance 200 pf/m. For longer lengths, contact <a href="#">Bently Nevada Tech Support</a> . |

**For more information on this product, please refer to the Velomitor CT Piezo-Velocity Transducer User Guide (document 125389).**

## Compliance and Certifications

### FCC

This device complies with part 15 of the FCC Rules. Operation is subject to the following two conditions:

- This device may not cause harmful interference.
- This device must accept any interference received, including interference that may cause undesired operation.

### EMC

EMC Directive 2014/30/EU

### RoHS

RoHS Directive 2011/65/EU

### ATEX

60079-01

60079-07

60079-11

60079-15

ATEX Directive 2014/34/EU

## Hazardous Area Approvals



For the detailed listing of country and product-specific approvals, refer to the [Approvals Quick Reference Guide \(108M1756\)](#).

For additional technical documentation, please log in to [bntechsupport.com](http://bntechsupport.com) and access the Bently Nevada Media Library.


### cNRTLus

#### 190501 (Agency Approval Options 01 through 04)


|                    |                                                                                                                                                                                                                                                                                                                                                                                                                      |
|--------------------|----------------------------------------------------------------------------------------------------------------------------------------------------------------------------------------------------------------------------------------------------------------------------------------------------------------------------------------------------------------------------------------------------------------------|
| Intrinsically Safe | <p>Ex ia IIC T3:<br/>           Class I, Div 1, Groups A, B, C, D,<br/>           Class II, Group E, F and G<br/>           Class III</p> <p>AEx ia IIC T3:<br/>           Class I, Div 1, Groups A, B, C, D;<br/>           Class II, Groups E, F, G<br/>           Class III</p> <p>Install per drawing 167536<br/>           T3 @ <math>-55^{\circ}\text{C} \leq \text{Tamb} \leq +121^{\circ}\text{C}</math></p> |
| Non-Incendive      | <p>AEx ec T3<br/>           Class I, Division 2, Groups A, B, C and D</p> <p>Install per drawing 167536<br/>           T3 @ <math>-55^{\circ}\text{C} \leq \text{Tamb} \leq +121^{\circ}\text{C}</math></p>                                                                                                                                                                                                          |

## ATEX/IECEx

### 190501 Entity Parameters

 II 1 G

Ex ia IIC T3 Ga

 II 3 D

Ex ec IIC T3 Gc

Ex tc IIIC T200°C Dc

T3@ Ta = -55°C to 121°C

| Zone 0/1  | Zone 2    |
|-----------|-----------|
| Ui= 30V   | Ui= 30V   |
| Ii= 100mA | Ii= 100mA |
| Pi= 0.75W | Pi= 1.14W |
| Ci=27.2nF |           |
| Li= 0     |           |

## Hazardous Area Conditions of Safe Use

### ATEX/IECEx

#### Zone 0/1:

Equipment must be connected to equipment, which meets the abovelisted entity parameters.

The cables type A or B (in compliance with EN 60079-25) must respect the cable parameters listed with the entity parameters.

#### Zone 2 :

The supply electrical parameters shall not exceed the values mentioned in the tables above.

## Ordering Information

### Velomitor CT Velocity Transducer

#### 190501-AA-BB-CC

| <b>A: Mounting Hardware Option</b> |                                               |
|------------------------------------|-----------------------------------------------|
| <b>00</b>                          | No stud                                       |
| <b>01</b>                          | Stud 3/8-in 24 to 3/8-in 24                   |
| <b>02</b>                          | Stud 3/8-in 24 to 1/2-in 20                   |
| <b>03</b>                          | Adhesive Stud 3/8-in 24                       |
| <b>04</b>                          | Stud M6x1 with 3/8-in 24 adapter              |
| <b>05</b>                          | Adhesive Stud M6x1 with 3/8-24 adapter        |
| <b>06</b>                          | Stud 3/8-in 24 to 1/4-in 28                   |
| <b>07</b>                          | Plate Stud 3/8-in 24 to 3/8-in 24             |
| <b>08</b>                          | Plate Stud 3/8-in 24 to 1/2-in 20             |
| <b>09</b>                          | Plate Stud 3/8-in 24 to 1/4-in NPT            |
| <b>10</b>                          | Plate Stud M6x1 to M6x1with 3/8-in 24 adapter |
| <b>11</b>                          | Plate Stud 3/8-in 24 to 1/4-in 28             |
| <b>12</b>                          | Plate Stud 3/8-in 24 to M8x1                  |
| <b>13</b>                          | Quick disconnect stud                         |
| <b>14</b>                          | Adapter, 3/8-in 24 to 1/4-in 20               |
| <b>15</b>                          | Adapter, 3/8-in 24 to 5/16-in 18              |
| <b>16</b>                          | Adapter, 3/8-in 24 to 3/8-in 24               |
| <b>17</b>                          | Adapter, 3/8-in 24 to 3/8-in 16               |
| <b>18</b>                          | Adapter, 3/8-in 24 to 1/2-in 13               |
| <b>19</b>                          | Adapter, 3/8-in 24 to 1/4-in 18 NPT           |

|           |                                        |
|-----------|----------------------------------------|
| <b>20</b> | Adapter, 3/8-in 24 to 3/8-in 18 NPT    |
| <b>21</b> | Adapter, 3/8-in 24 to 1/2-in 14 NPT    |
| <b>22</b> | Adapter, 3/8-in 24 to 3/4-in 14 NPT    |
| <b>23</b> | Adapter, 3/8-in 24 to 1.0-in 11.5 NPT  |
| <b>24</b> | Adapter, 3/8-in 24 to 1.25-in 11.5 NPT |

#### **B: Connection Option**

|           |                                  |
|-----------|----------------------------------|
| <b>00</b> | MIL-C-5015 connection interface  |
| <b>99</b> | Unit with included 32-foot cable |

#### **C: Agency Approval Option**

|                      |                                                                      |
|----------------------|----------------------------------------------------------------------|
| <b>00</b>            | No Approvals                                                         |
| <b>01 through 04</b> | CSA/NRTL/C (Class I, Division 1), ATEX/IECEX/CSA (Class I, Zone 0/1) |

## Interconnect Cable

### CB2W100 - AAA

Description: Connectors: MIL-C 5015, 2 Socket, Splash Proof, Premium, isolated to blunt cut, Cable: 20 AWG, twisted pair, shielded, yellow Teflon jacket. LOCKING RING, ADAPTER SEAL, AND O-RING ARE INCLUDED.

#### **A: Length**

|            |                   |
|------------|-------------------|
| <b>015</b> | 15 ft (4.57 m)    |
| <b>032</b> | 32 ft (9.75 m)    |
| <b>064</b> | 64 ft (19.5 m)    |
| <b>112</b> | 112 ft (34.1 m)   |
| <b>125</b> | 125 ft (38.1 m)   |
| <b>150</b> | 150 feet (45.7 m) |
| <b>200</b> | 200 feet (61.0 m) |

|            |                   |
|------------|-------------------|
| <b>250</b> | 250 feet (76.2 m) |
|------------|-------------------|

## Accessories

|             |                                                                                                                                                                                                                                                                                                 |
|-------------|-------------------------------------------------------------------------------------------------------------------------------------------------------------------------------------------------------------------------------------------------------------------------------------------------|
| 128608-02   | 1/2-in NPT conduit adapter                                                                                                                                                                                                                                                                      |
| 04284020-01 | Adhesive mount base kit. The adhesive mount base kit design is for machines with thin casings that do not permit drilling and tapping a mounting hole. Kit contains material (adhesive and bases) for 2 each 3/8-in 24 UNF adhesive-mount bases. One kit can outfit 2 Velomitor CT Transducers. |

## Spare Mounting Adapters

All mounting adapters are made from 300 series stainless steel.

## Standard Studs

|          |                                                    |
|----------|----------------------------------------------------|
| 04365657 | 3/8-in 24 to 3/8-in 24 stud                        |
| 87910-01 | 3/8-in 24 to 1/2-in 20 stud                        |
| 87931-01 | M6x1 to M6x1 metric stud (requires metric adapter) |
| 87055-01 | 3/8-in 24 to M6x1 metric adapter                   |
| 89139-01 | 3/8-in 24 to 1/4-in 28 stud                        |

## Hex Plate Studs

|           |                                                   |
|-----------|---------------------------------------------------|
| 107756-01 | 3/8-in 24 to 3/8-in 24 plate stud                 |
| 107755-01 | 3/8-in 24 to 1/2-in 20 plate stud                 |
| 107754-01 | 3/8-in 24 to 1/4-in NPT plate stud                |
| 107757-01 | M6x1 to M6x1 plate stud (requires metric adapter) |
| 125094-01 | 3/8-in 24 to M8x1 metric plate stud               |
| 128038-01 | 3/8-in 24 to 1/4-in 28 Plate Stud                 |

## Quick Disconnect Components

The following three components are included with the quick disconnect mounting option for the Velomitor CT Transducer. The quick disconnect option allows you to remove the transducer without rotating it, allowing you to keep the cable connected to the transducer.

|           |                                                                                            |
|-----------|--------------------------------------------------------------------------------------------|
| 128689-01 | 3/8-in 24 to 1¼-in 16 quick disconnect stud base. Attached to the machine.                 |
| 43055-01  | 1¼-in 16 mounting base nut. Interface between stud base and transducer piece.              |
| 128690-01 | 3/8-in 24 quick disconnect stud transducer piece. Attached to the Velomitor CT Transducer. |

## Fittings

Conduit fittings allow connection of flexible, metal, liquid-tight conduit or armor to the conduit adapter.

|          |                                                                                                                                                                                                                                                                                        |
|----------|----------------------------------------------------------------------------------------------------------------------------------------------------------------------------------------------------------------------------------------------------------------------------------------|
| 03839201 | 1/2-in NPT straight male conduit fitting. For connecting flexible, liquid-tight conduit to the conduit adapter or a weatherproof enclosure.                                                                                                                                            |
| 03850000 | 1/2-in NPT straight, male compression-type fitting. For connecting Teflon™-coated 3/8-in stainless steel armor to the transducer or a weatherproof enclosure. Fitting will fit Teflon™-coated armor with a maximum outer diameter of 13.8 mm (0.543 in) (including Teflon™ thickness). |

## Teflon-Coated Stainless Steel Armor

### 106924-AA



This part includes the Teflon-coated armor but not the cable. You will require 2 1/2-in NPT compression fittings (part number 03850000) to attach the armor to the conduit adapter and terminate it at an enclosure.

#### A: Armor Length Option in Feet

Order in increments of 10 ft (3.0 m)

Minimum Length: 10 ft (3.0 m)

Maximum Length: 60 ft (18.3 m)

## Flexible Metal Conduit

### 14847-AA

#### A: Flexible Conduit Length Option in Feet

Order in increments of 1 ft (0.3 m)

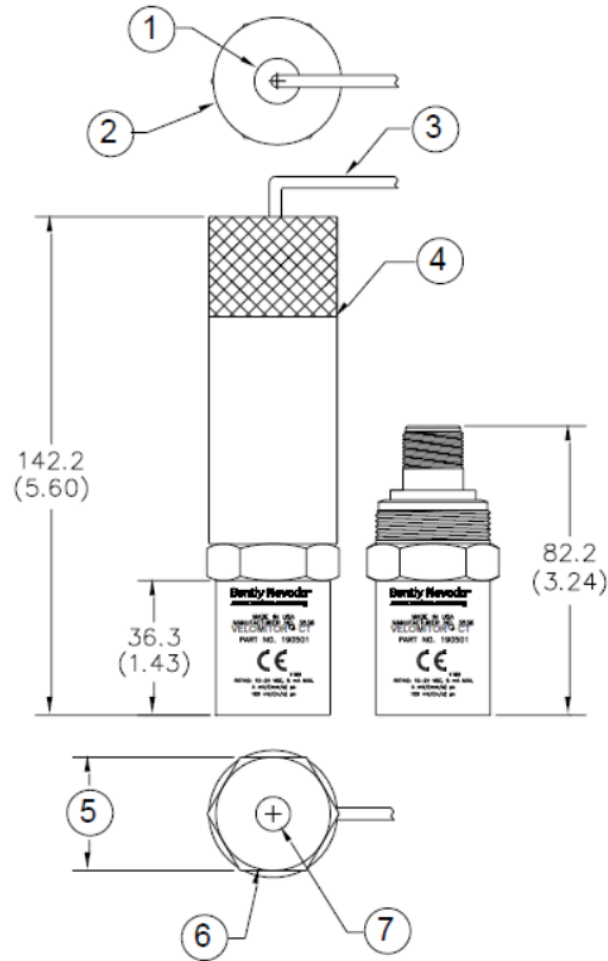
Minimum Length: 1 ft (0.3 m)

Maximum Length: 99 ft (30.2 m)

|           |                                                                                                                 |
|-----------|-----------------------------------------------------------------------------------------------------------------|
| 106769-01 | Terminal housing. Provides a convenient interface between the transducer signal cable and monitor signal cable. |
|-----------|-----------------------------------------------------------------------------------------------------------------|

## Graphs and Figures

Note: All dimensions shown are in millimeters (inches) unless noted otherwise.



1. 1/2" NPT x 12.2 DP (1/2" NPT x 0.48 DP)
2. 35.6 (1.40) diameter
3. Cable (not included)
4. Conduit adaptor P/N 128608-02 (not included)
5. 31.8 (1.25) hex flat
6. 31.5 (1.24) diameter
7. 3/8-24 UNF X 8.9 DP (3/8-24 UNF X 0.35 DP)

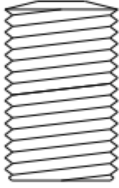
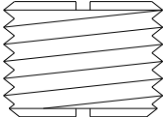
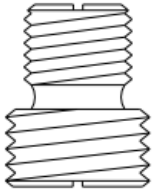
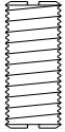
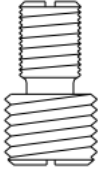
**Figure 1: Velomitor CT Outline Drawing**

## Spare Mounting Adapters



All mounting adapters are made from 300 series stainless steel. Illustrations shown are not to scale.

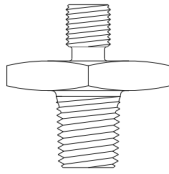
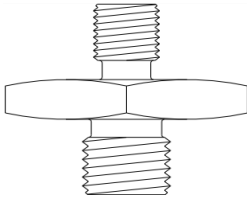
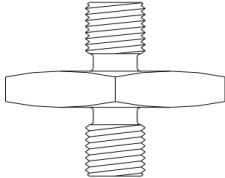
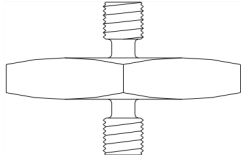
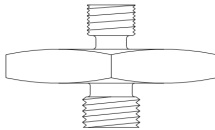
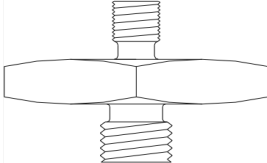
**Table 1: Standard Studs**

| Part Number | Size             | Illustration                                                                          |
|-------------|------------------|---------------------------------------------------------------------------------------|
| 04365657    | 3/8-24 to 3/8-24 |    |
| 87055-01    | 3/8-24 to M6X1   |    |
| 87910-01    | 3/8-24 to 1/2-20 |   |
| 87931-01    | M6X1 to M6X1     |  |
| 89139-01    | 3/8-24 to 1/4-28 |  |

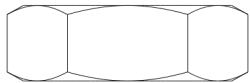
**Table 2: Adhesive Studs**

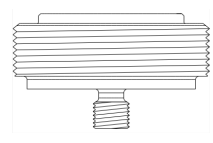
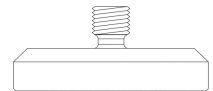
| Part Number | Size   | Illustration                                                                          |
|-------------|--------|---------------------------------------------------------------------------------------|
| 04284020    | 3/8-24 |  |

**Table 3: 1-3/8 Hex Plate Studs**

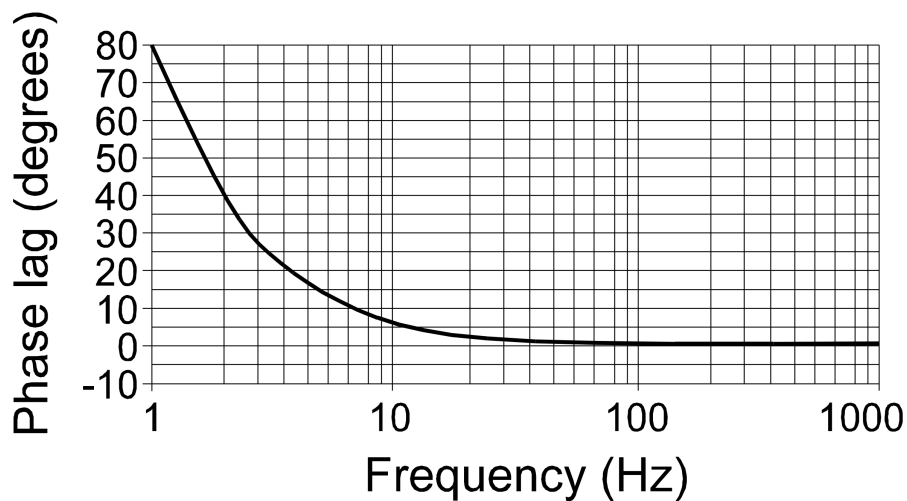
| Part Number | Size                     | Illustration                                                                          |
|-------------|--------------------------|---------------------------------------------------------------------------------------|
| 107754-01   | 3/8-24 UNF to 1/4 NPT    |    |
| 107755-01   | 3/8-24 UNF to 1/2-20 UNF |    |
| 107756-01   | 3/8-24 to 3/8-24         |    |
| 107757-01   | M6X1 to M6X1             |   |
| 125094-01   | 3/8-24 UNF to M8X1       |  |
| 128038-01   | 3/8-24 UNF to 1/4-28 UNF |  |

**Table 4: Quick Disconnect Studs**

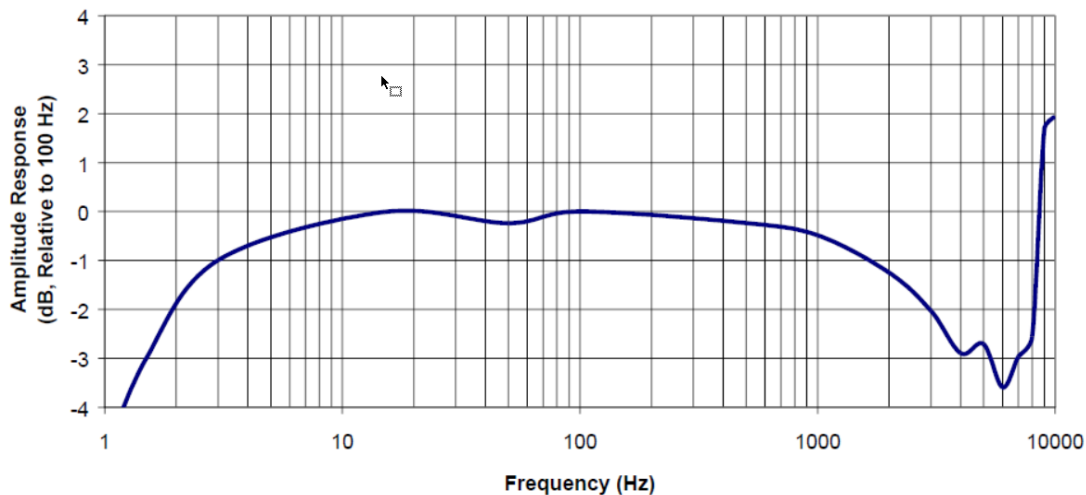
| Part Number | Description             | Illustration                                                                          |
|-------------|-------------------------|---------------------------------------------------------------------------------------|
| 43055-01    | Union Mounting Base Nut |  |

| Part Number | Description                       | Illustration                                                                        |
|-------------|-----------------------------------|-------------------------------------------------------------------------------------|
| 128689-01   | Quick Disconnect Stud Base        |  |
| 128690-01   | Quick Disconnect Transducer Piece |  |

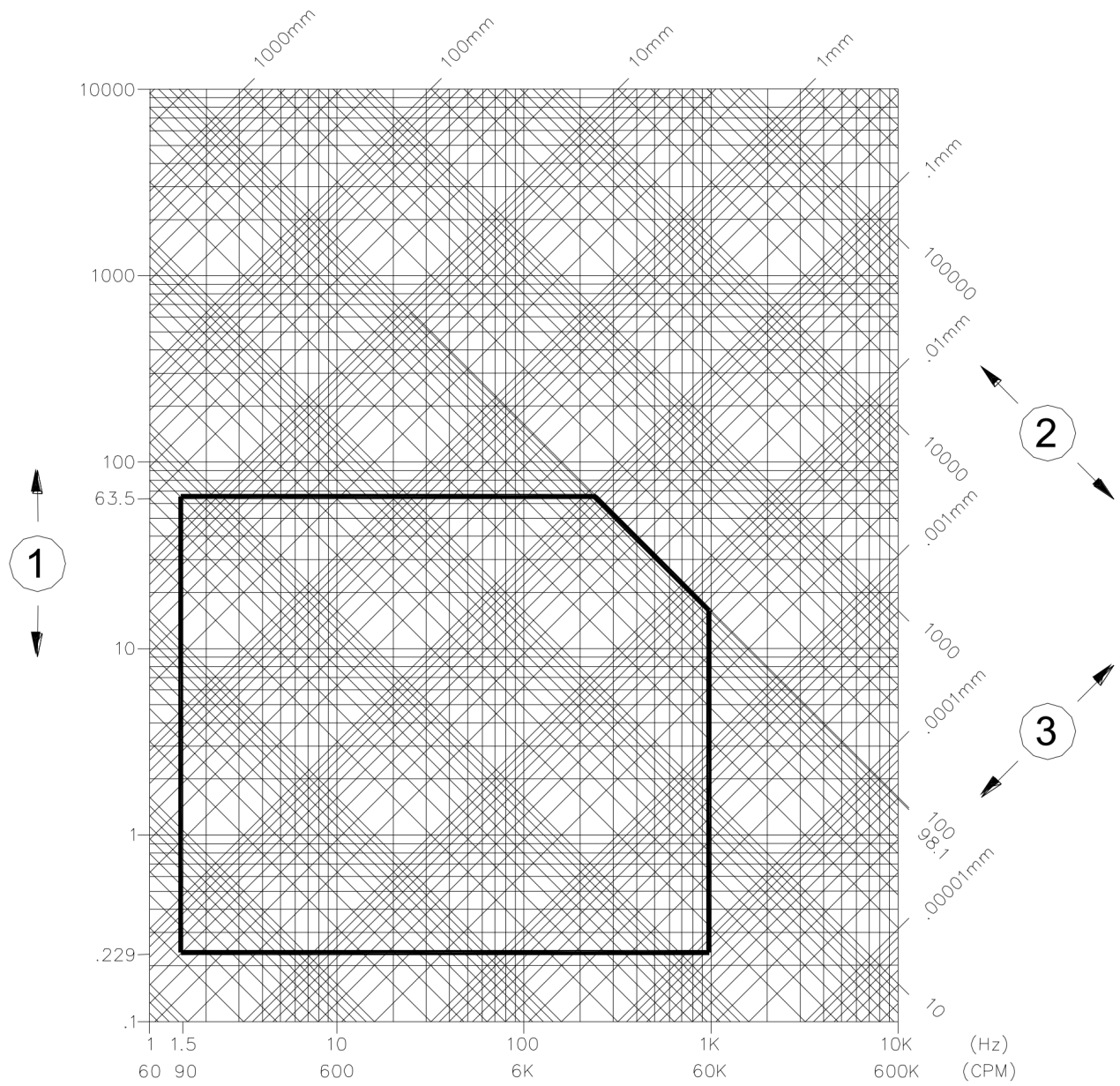
## Graphs



**Figure 2: Typical Phase Response**

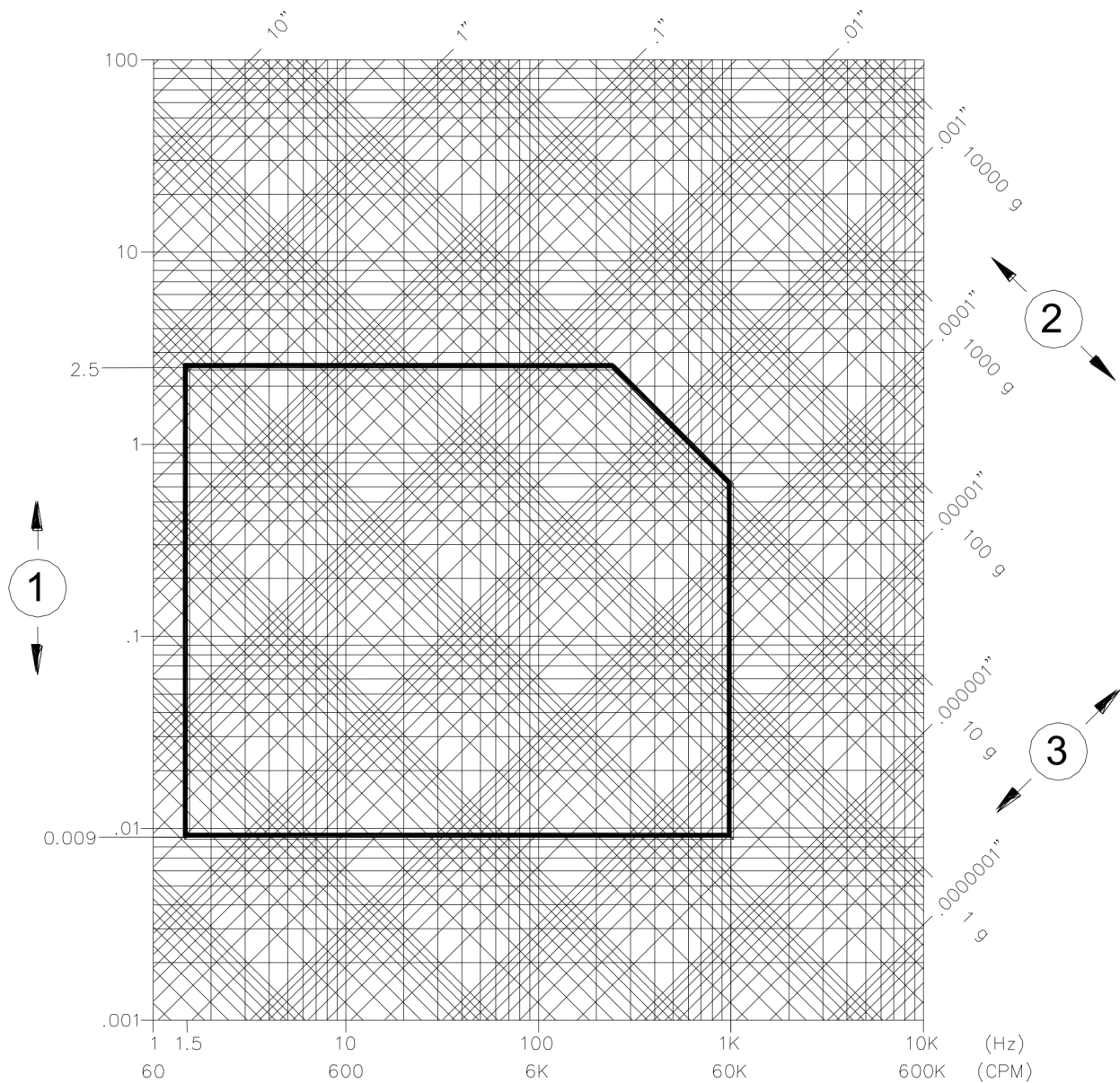


**Figure 3: Typical Amplitude Response**



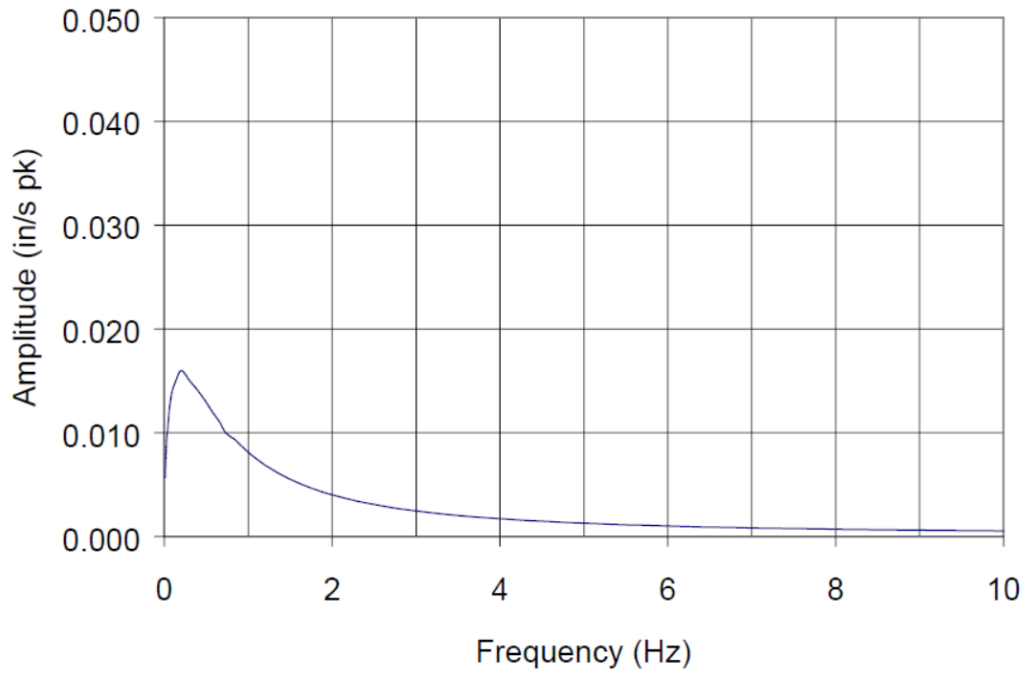
1. Velocity axis (mm/s peak-peak)
2. Displacement axis (mm peak-peak)
3. Acceleration axis (m/s<sup>2</sup> peak-peak)

**Figure 4: Operating Range for Metric Units**



1. Velocity axis (in./s peak-peak)
2. Displacement axis (in. peak-peak)
3. Acceleration axis (g peak-peak)

**Figure 5: Operating Range for English Units**



**Figure 6: Typical Low Frequency Noise Floor**

Copyright 2026 Baker Hughes Company. All rights reserved.

Bently Nevada, a Baker Hughes Company  
1631 Bently Parkway South, Minden, Nevada USA 89423  
<https://bntechsupport.com>