



## *Installation Instructions*

# ControlLogix® Battery Module

Catalog Number: 1756-BATM

---

**IMPORTANT**

Installation instructions ship with each component. If you want other documentation, you must order it separately. Refer to Additional Manuals on page 31.

---

### **Before You Begin**

Use this document to install a ControlLogix® Battery Module:

- You can use a battery module only with the following controllers:
  - 1756-L55Mxx controller
  - 1756-L61, -L62, or -L63 controller
- You can install only one battery module per controller.

### Important User Information

Solid state equipment has operational characteristics differing from those of electromechanical equipment. *Safety Guidelines for the Application, Installation and Maintenance of Solid State Controls* (Publication SGI-1.1 available from your local Rockwell Automation sales office or online at <http://www.ab.com/manuals/gi>) describes some important differences between solid state equipment and hard-wired electromechanical devices. Because of this difference, and also because of the wide variety of uses for solid state equipment, all persons responsible for applying this equipment must satisfy themselves that each intended application of this equipment is acceptable.



In no event will Rockwell Automation, Inc. be responsible or liable for indirect or consequential damages resulting from the use or application of this equipment.

The examples and diagrams in this manual are included solely for illustrative purposes. Because of the many variables and requirements associated with any particular installation, Rockwell Automation, Inc. cannot assume responsibility or liability for actual use based on the examples and diagrams.

No patent liability is assumed by Rockwell Automation, Inc. with respect to use of information, circuits, equipment, or software described in this manual.

Reproduction of the contents of this manual, in whole or in part, without written permission of Rockwell Automation, Inc. is prohibited.

Throughout this manual we use notes to make you aware of safety considerations.

<b>WARNING</b> 	Identifies information about practices or circumstances that can cause an explosion in a hazardous environment, which may lead to personal injury or death, property damage, or economic loss.
<b>ATTENTION</b> 	Identifies information about practices or circumstances that can lead to personal injury or death, property damage, or economic loss. Attentions help you: <ul style="list-style-type: none"><li>• identify a hazard</li><li>• avoid a hazard</li><li>• recognize the consequence</li></ul>
<b>IMPORTANT</b>	Identifies information that is critical for successful application and understanding of the product.
<b>SHOCK HAZARD</b> 	Labels may be located on or inside the drive to alert people that dangerous voltage may be present.

**WARNING**

When you insert or remove the module while backplane power is on, an electrical arc can occur. This could cause an explosion in hazardous location installations. Be sure that power is removed or the area is nonhazardous before proceeding.

Repeated electrical arcing causes excessive wear to contacts on both the module and its mating connector. Worn contacts may create electrical resistance that can affect module operation.

**ATTENTION****Preventing Electrostatic Discharge**

This equipment is sensitive to electrostatic discharge, which can cause internal damage and affect normal operation. Follow these guidelines when you handle this equipment:

- Touch a grounded object to discharge potential static.
- Wear an approved grounding wriststrap.
- Do not touch connectors or pins on component boards.
- Do not touch circuit components inside the equipment.
- If available, use a static-safe workstation.
- When not in use, store the equipment in appropriate static-safe packaging.

### Equipment that You Need

The equipment that you need to install the battery module depends on how you mount the module. You have these options:

- Mount the Battery Module Directly to a Panel
- Mount the Battery Module to a DIN Rail

### Mount the Battery Module Directly to a Panel

To mount the battery module directly to a panel, you need the following equipment:

- #2 phillips screwdriver
- drill
- screws and washers

For this:	You need:	
	Quantity	Description:
top mounting tabs	2	M4 or M5 (#10 or #12) phillips screw
	2	flat washer
	2	split lock washer
bottom mounting tab	1	M4 or M5 (#10 or #12) phillips screw or SEM screw (phillips screw with attached star washer)
	1	star washer (not required for SEM screws)

### Mount the Battery Module to a DIN Rail

To mount the battery module to a DIN rail, you need the following equipment:

- #2 phillips screwdriver

## What You Need to Do

Before you install a battery module, do these preliminary tasks:

- ☑ Install a ControlLogix chassis according to the *ControlLogix Chassis Installation Instructions*, publication 1756-IN080.
- ☑ Install a ControlLogix power supply according to the corresponding installation instructions:

Install this power supply:	According to this publication:
1756-PA72	<i>ControlLogix Power Supplies Installation Instructions</i> , publication 1756-5.67
1756-PB72	
1756-PA75	<i>ControlLogix Power Supplies Installation Instructions</i> , publication 1756-5.78
1756-PB75	
1756-PA75R	<ul style="list-style-type: none"> <li>• <i>ControlLogix Redundant Power Supplies Installation Instructions</i>, publication 1756-IN573</li> <li>• <i>ControlLogix Redundant Power Supplies Chassis Adapter Module Installation Instructions</i>, publication 1756-IN574</li> </ul>
1756-PB75R	

- ☑ Install a ControlLogix controller according to the *ControlLogix Controller and Memory Board Installation Instructions*, publication 1756-IN101.

## 6 ControlLogix® Battery Module



---

To install a battery module, do these tasks:

- Make Sure that You Have All the Components
- Select a Location for the Module
- Select a Mounting Option
- Mount the Battery Module to a DIN Rail
- Mount the Battery Module Directly to a Panel
- Attach the Cable to the Controller
- Install the Battery Assembly
- Check the BAT LED
- Estimate Battery Life

## Make Sure that You Have All the Components

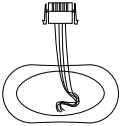
The 1756-BATM battery module includes these components:

Component:	Description:
 <p data-bbox="358 636 399 651">31298</p>	<p data-bbox="521 352 653 374">battery module</p> <p data-bbox="521 412 909 526">The cable is already attached to the module. The cable includes a ferrite core for noise suppression. The ferrite core is close to the end of the cable.</p>
 <p data-bbox="308 798 353 813">31325</p>	<p data-bbox="521 689 774 712">1756-BATA battery assembly</p>
	<p data-bbox="521 863 632 886">battery label</p>
	<p data-bbox="521 938 767 961">universal mounting brackets</p>
	<p data-bbox="521 1059 899 1082">screws for the universal mounting brackets</p>
	<p data-bbox="521 1158 640 1180">DIN rail locks</p>

## Select a Location for the Module

Mount the battery module as follows:

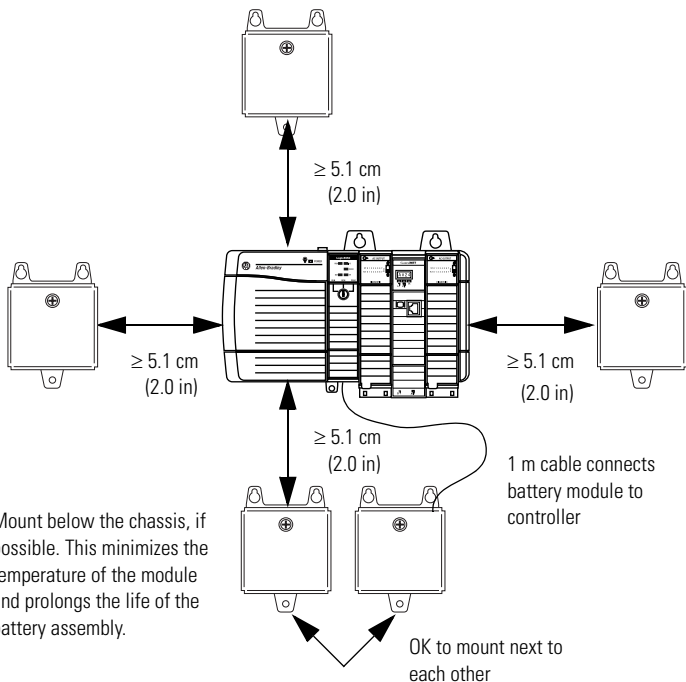

Mount below the chassis, if possible. This minimizes the temperature of the module and prolongs the life of the battery assembly.

On a horizontal panel, mount the module with the door facing up.

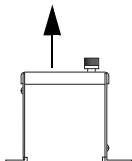

Leave space to remove the battery assembly.

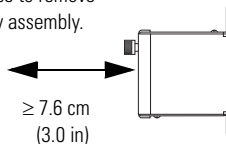

## Select a Mounting Option

If you want to:	Then go to page:
Mount the Battery Module to a DIN Rail	9
Mount the Battery Module Directly to a Panel	11

## Mount the Battery Module to a DIN Rail

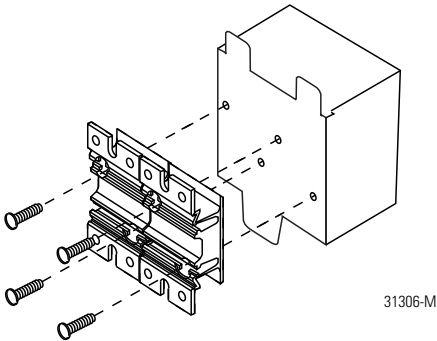

1. Align the holes on the mounting brackets with the holes on the back of the battery module.
2. Insert and tighten the screws.
3. Attach the battery module to the DIN rail.

## 10 ControlLogix® Battery Module

---

4. Attach a DIN rail lock (A-B catalog number 1492-EA35) on each side of the battery module.

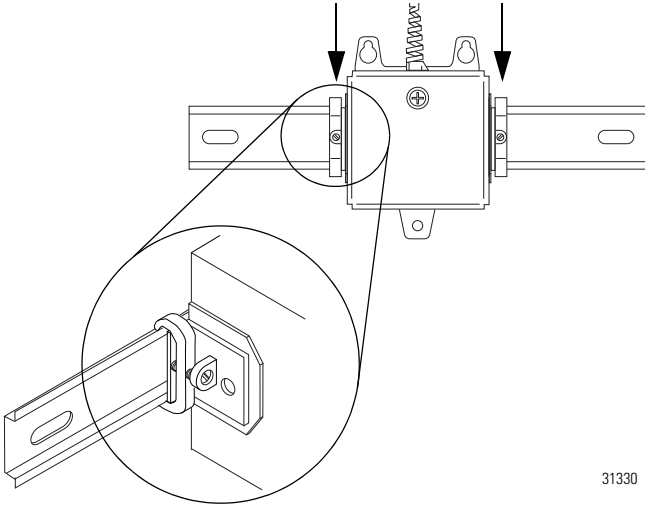

31330

5. Ground the battery module to the enclosure.

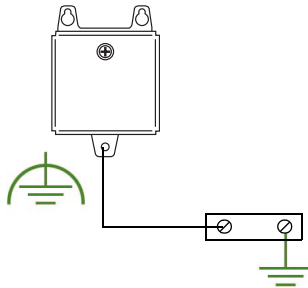

6. Go to “Attach the Cable to the Controller” on page 14.

## Mount the Battery Module Directly to a Panel

To mount the battery module directly to a panel:

- Drill the Mounting Holes
- Mount the Battery Module

### Drill the Mounting Holes

1. Are you installing the battery module above existing components?

<b>If:</b>	<b>Then:</b>
Yes	Protect the existing components from metal chips that may fall as you drill the mounting holes.
No	Go to step 2.

2. On the panel of the enclosure, mark the holes for the mounting tabs of the battery module. Use the template on page 25.
3. Drill the holes for the mounting tabs.

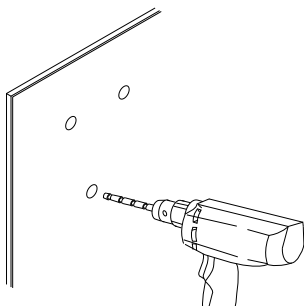

31301-M

## Mount the Battery Module

1. To make an electrical connection between the battery module and the enclosure, scrape the paint off the panel of the enclosure.
2. Install the hardware for the top mounting tabs.

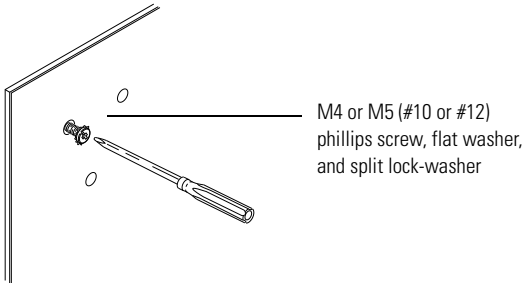

31301-M

3. Slide the top tabs of the battery module over the screws.

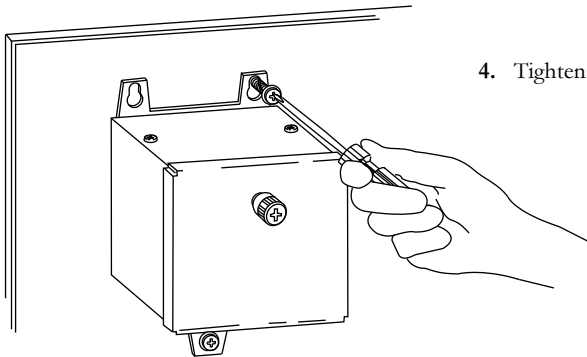

31302-M

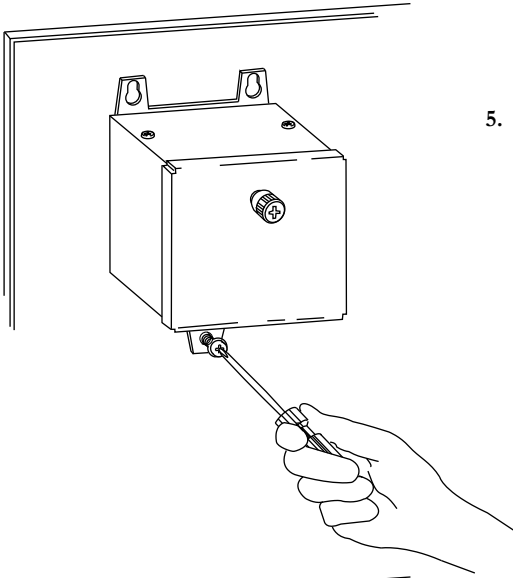

5. Install and tighten the hardware for the bottom tab.

31302-M

## Attach the Cable to the Controller

**WARNING**



An electrical arc can occur when you:

- connect or disconnect the battery
- connect or disconnect the battery module from the controller

This could cause an explosion in hazardous location installations. Be sure that power is removed or the area is nonhazardous before proceeding.

For Safety information on the handling of lithium batteries, including handling and disposal of leaking batteries, see Guidelines for Handling Lithium Batteries, publication AG 5-4.

1. Is a 1756-BA1 battery connected to the controller?

<b>if:</b>	<b>Then:</b>
Yes	Go to step 2.
No	Go to step 3

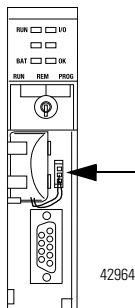

2. Disconnect the 1756-BA1 battery.

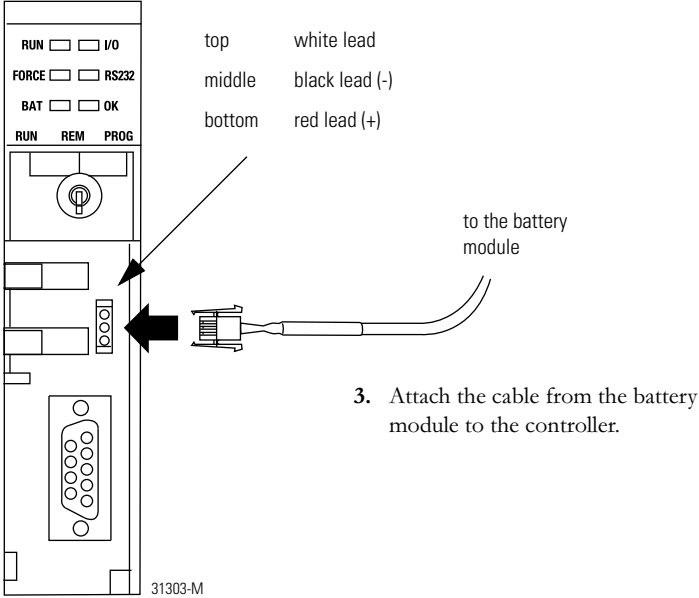

## Install the Battery Assembly

**ATTENTION**



Only install a 1756-BATA battery. If you install a different battery, you may damage the controller

**IMPORTANT**

Connect the battery assembly to the battery module only when you are ready to use it. Even if the battery module is not connected to the controller, the battery assembly begins to discharge once you connect it to the battery module.

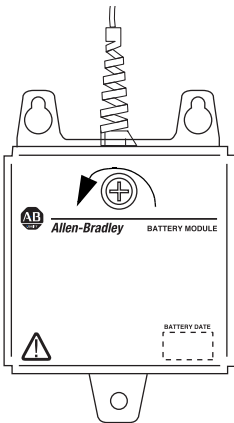

31298

1. Remove the door of the battery module.

- Put the battery assembly into the battery module with the wires facing outward.

**WARNING**

When you connect or disconnect the battery an electrical arc can occur. This could cause an explosion in hazardous location installations. Be sure that power is removed or the area is nonhazardous before proceeding.

For Safety information on the handling of lithium batteries, including handling and disposal of leaking batteries, see Guidelines for Handling Lithium Batteries, publication AG 5-4.

no connection



31304-M

- Connect the battery assembly to the battery module.
- Replace the door of the battery module.

## 18 ControlLogix® Battery Module

---

5. Write on the battery label the date that you install the battery assembly.

---

**EXAMPLE**

7/9/01

Battery was installed on this date.

6. Attach the label to the front of the battery module.

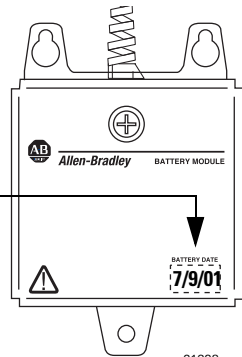

## Check the BAT LED

1. Turn on the chassis power.

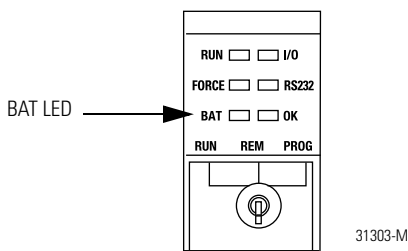

2. Is the BAT LED off?

<b>If:</b>	<b>Then:</b>
Yes	The battery module is correctly installed.
No	Go to step 3.

3. Check that the battery module is correctly connected to the controller.
4. Check that the battery assembly is correctly connected to the battery module.
5. If the BAT LED remains on, install another battery assembly (catalog # 1756-BATA).
6. If the BAT LED remains on after you complete step 5, contact your Rockwell Automation representative or local distributor.

## Estimate Battery Life

When the battery is about 50 percent discharged, the controller provides the following warnings:

- On the front of the controller, the BAT LED turns on (solid red).
- A minor fault occurs (type 10, code 10).

To estimate how long the battery will support the memory of the controller:

1. Determine the temperature ( $^{\circ}$  C) 1 in. below the battery module.
2. Determine the percentage of time that the controller is powered *off* per week.

---

**EXAMPLE**

If a controller is off:

- 8 hr/day during a 5-day work week
- all day Saturday and Sunday

Then the controller is off 52% of the time:

1. total hours per week =  $7 \times 24 + 168$  hours
  2. total off hours per week =  $(5 \text{ days} \times 8 \text{ hr/day}) + \text{Saturday} + \text{Sunday} = 88$  hours
  3. percentage off time =  $88/168 = 52\%$
- 

4. Using “Table 1 Worst-case estimates of life for the 1756-BATA battery” on page 21, determine the estimated worst-case battery life before and after the BAT LED turns on.
5. For each year of battery life, decrease the time before the BAT LED turns on by the percentage that is shown in the table. (Do not decrease the time after the BAT LED turns on.)

**IMPORTANT**

If the BAT LED turns on when you apply power to the controller, the battery life may be less than the table below indicates. Some of the battery life may have been used up while the controller was off and unable to turn on the BAT LED.

**Table 1 Worst-case estimates of life for the 1756-BATA battery**

Controller:	Temp:	Time before BAT LED turns on:			Time after BAT LED turns on and then power off 100%:
		Power off 100%	Power off 50%	Yearly decrease:	
1756-L55M12	60° C	190 days	396 days	11%	190 days
1756-L55M13	25° C	299 days	562 days	5%	299 days
	0° C	268 days	562 days	6%	268 days
1756-L55M14	60° C	130 days	270 days	11%	139 days
	25° C	213 days	391 days	5%	228 days
	0° C	180 days	381 days	6%	193 days
1756-L55M16	60° C	71 days	160 days	13%	76 days
	25° C	133 days	253 days	5%	142 days
	0° C	105 days	220 days	6%	112 days
1756-L55M22 1756-L55M23	Use the values for the 1756-L55M13 controller.				
1756-L55M24	Use the values for the 1756-L55M14 controller.				
1756-L61	60° C	98 days	204 days	11%	104 days
1756-L62	25° C	146 days	268 days	5%	157 days
1756-L63		105 days	222 days	6%	113 days

## Specifications

Description:	Value:
Supply Power	input power    15 mA max @ 5.1V dc
	output power    20 mA max @ 3.6V dc
Maximum Continuous Discharge Current	20 mA
Operating Temperature	IEC 60068-2-1 (Test Ad, Operating Cold), IEC 60068-2-2 (Test Bd, Operating Dry Heat), IEC 60068-2-14 (Test Nb, Operating Thermal Shock): <ul style="list-style-type: none"> <li>• 0° to 60° C (32 to 140° F)</li> </ul>
Storage Temperature	IEC 60068-2-1 (Test Ab, Un-packaged Non-operating Cold), IEC 60068-2-2 (Test Bb, Un-packaged Non-operating Dry Heat), IEC 60068-2-14 (Test Na, Un-packaged Non-operating Thermal Shock): <ul style="list-style-type: none"> <li>• ≤30°C (86°F)</li> </ul>
Relative Humidity	IEC 60068-2-30 (Test Db, Un-packaged Non-operating Damp Heat):
	operating        5 to 95% non-condensing
	storage           ≤30%
Vibration	IEC 60068-2-6 (Test Fc, Operating): <ul style="list-style-type: none"> <li>• 2g @ 10-500Hz</li> </ul>
Operating Shock	IEC 60068-2-27 (Test Ea, Unpackaged Shock):
	panel mounted    30g
	DIN rail mounted    15g

<b>Description:</b>	<b>Value:</b>
Non-Operating Shock	IEC 60068-2-27 (Test Ea, Unpackaged Shock):
	panel mounted 50g
	DIN rail mounted 15g
Emissions	CISPR 11: <ul style="list-style-type: none"> <li>• Group 1, Class A</li> </ul>
ESD Immunity	IEC 61000-4-2: <ul style="list-style-type: none"> <li>• 6kV contact discharges</li> <li>• 8kV air discharges</li> </ul>
Radiated RF Immunity	IEC 61000-4-3: <ul style="list-style-type: none"> <li>• 10V/m with 1kHz sine-wave 80%AM from 80MHz to 2000MHz</li> </ul>
Enclosure Type Rating	None (open-style)
Cable	1 m category 3 <sup>(1)</sup>
Replacement Battery Assembly	1756-BATA (10g lithium)

## 24 ControlLogix® Battery Module

Description:	Value:	
Certifications: (when product is marked)	UR	UL Recognized Component Industrial Control Equipment
	CSA	CSA Certified Process Control Equipment
	CSA	CSA Certified Process Control Equipment for Class I, Division 2 Group A,B,C,D Hazardous Locations
	CE <sup>(2)</sup>	European Union 89/336/EEC EMC Directive, compliant with: <ul style="list-style-type: none"> <li>• EN 50082-2; Industrial Immunity</li> <li>• EN 61326; Meas./Control/Lab., Industrial Requirements</li> <li>• EN 61000-6-2; Industrial Immunity</li> <li>• EN 61000-6-4; Industrial Emissions</li> </ul>
	C-Tick <sup>(2)</sup>	Australian Radiocommunications Act, compliant with: <ul style="list-style-type: none"> <li>• AS/NZS CISPR 11; Industrial Emissions</li> </ul>
	EEx <sup>(2)</sup>	European Union 94/9/EC ATEX Directive, compliant with: <ul style="list-style-type: none"> <li>• EN 50021; Potentially Explosive Atmospheres, Protection “n” (Zone 2)</li> </ul>

<sup>(1)</sup> Use this Conductor Category information for planning conductor routing. Refer to Publication 1770-4.1, “Industrial Automation Wiring and Grounding Guidelines”.

<sup>(2)</sup> See the Product Certification link at [www.ab.com](http://www.ab.com) for Declarations of Conformity, Certificates, and other certification details.

## Mounting Template

Cut out the following template and use it to mark the holes for the mounting tabs of the battery module.

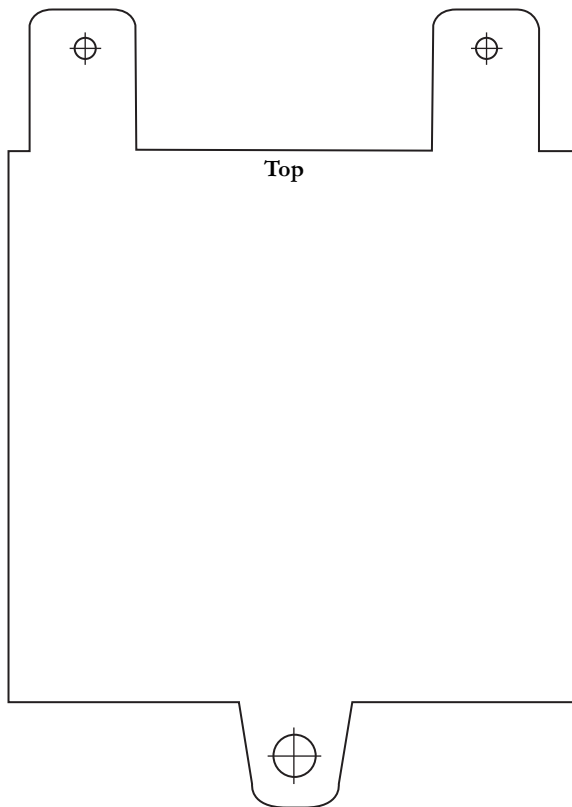

31299



## Dimensions

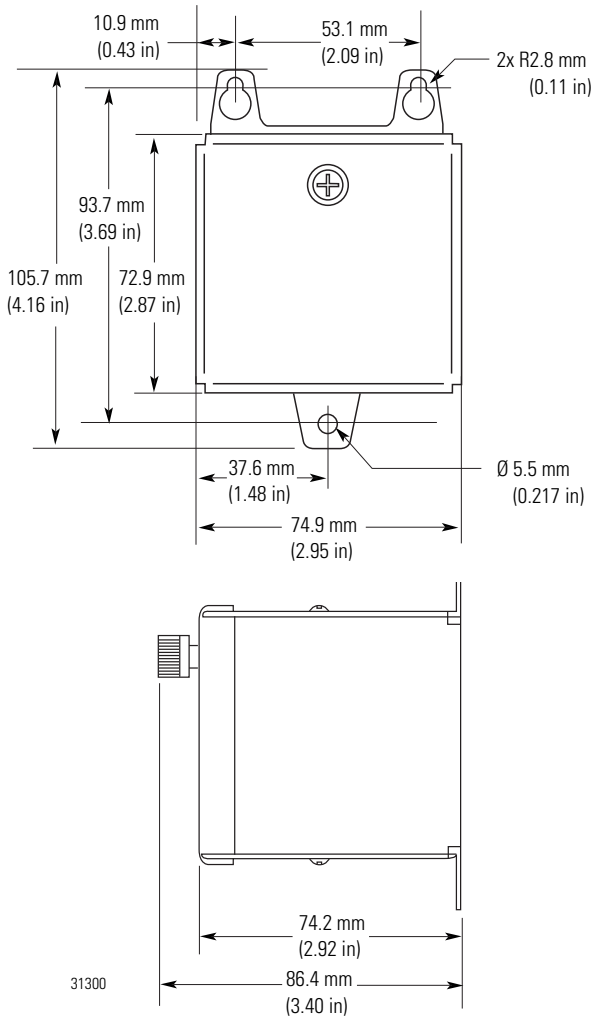

## Environment and Enclosure Information

---

**ATTENTION**



### Environment and Enclosure

This equipment is intended for use in a Pollution Degree 2 industrial environment, in overvoltage Category II applications (as defined in IEC publication 60664-1), at altitudes up to 2000 meters without derating.

This equipment is considered Group 1, Class A industrial equipment according to IEC/CISPR Publication 11. Without appropriate precautions, there may be potential difficulties ensuring electromagnetic compatibility in other environments due to conducted as well as radiated disturbance.

This equipment is supplied as "open type" equipment. It must be mounted within an enclosure that is suitably designed for those specific environmental conditions that will be present and appropriately designed to prevent personal injury resulting from accessibility to live parts. The interior of the enclosure must be accessible only by the use of a tool. Subsequent sections of this publication may contain additional information regarding specific enclosure type ratings that are required to comply with certain product safety certifications.

See NEMA Standards publication 250 and IEC publication 60529, as applicable, for explanations of the degrees of protection provided by different types of enclosure. Also, see the appropriate sections in this publication, as well as the Allen-Bradley publication 1770-4.1 ("Industrial Automation Wiring and Grounding Guidelines"), for additional installation requirements pertaining to this equipment.

---

---

## European Hazardous Location Approval

---

### European Zone 2 Certification

This equipment is intended for use in potentially explosive atmospheres as defined by European Union Directive 94/9/EC.

The LCIE (Laboratoire Central des Industries Electriques) certifies that this equipment has been found to comply with the Essential Health and Safety Requirements relating to the design and construction of Category 3 equipment intended for use in potentially explosive atmospheres, given in Annex II to this Directive. The examination and test results are recorded in confidential report No. 28 682 010.



Compliance with the Essential Health and Safety Requirements has been assured by compliance with EN 50021.

---

#### IMPORTANT

- This equipment is not resistant to sunlight or other sources of UV radiation.
  - The secondary of a current transformer shall not be open-circuited when applied in Class I, Zone 2 environments.
  - Equipment of lesser Enclosure Type Rating must be installed in an enclosure providing at least IP54 protection when applied in Class I, Zone 2 environments.
  - This equipment shall be used within its specified ratings defined by Allen-Bradley.
  - Provision shall be made to prevent the rated voltage from being exceeded by transient disturbances of more than 40% when applied in Class I, Zone 2 environments.
-

## North American Hazardous Location Approval

<b>The following information applies when operating this equipment in hazardous locations:</b>	<b>Informations sur l'utilisation de cet équipement en environnements dangereux :</b>
<p>Products marked "CL I, DIV 2, GP A, B, C, D" are suitable for use in Class I Division 2 Groups A, B, C, D, Hazardous Locations and nonhazardous locations only. Each product is supplied with markings on the rating nameplate indicating the hazardous location temperature code. When combining products within a system, the most adverse temperature code (lowest "T" number) may be used to help determine the overall temperature code of the system. Combinations of equipment in your system are subject to investigation by the local Authority Having Jurisdiction at the time of installation.</p>	<p>Les produits marqués "CL I, DIV 2, GP A, B, C, D" ne conviennent qu'à une utilisation en environnements de Classe I Division 2 Groupes A, B, C, D dangereux et non dangereux. Chaque produit est livré avec des marquages sur sa plaque d'identification qui indiquent le code de température pour les environnements dangereux. Lorsque plusieurs produits sont combinés dans un système, le code de température le plus défavorable (code de température le plus faible) peut être utilisé pour déterminer le code de température global du système. Les combinaisons d'équipements dans le système sont sujettes à inspection par les autorités locales qualifiées au moment de l'installation.</p>
<p><b>WARNING</b></p>  <p><b>EXPLOSION HAZARD</b></p> <ul style="list-style-type: none"> <li>Do not disconnect equipment unless power has been removed or the area is known to be nonhazardous.</li> <li>Do not disconnect connections to this equipment unless power has been removed or the area is known to be nonhazardous. Secure any external connections that mate to this equipment by using screws, sliding latches, threaded connectors, or other means provided with this product.</li> <li>Substitution of components may impair suitability for Class I, Division 2.</li> <li>If this product contains batteries, they must only be changed in an area known to be nonhazardous.</li> </ul>	<p><b>AVERTISSEMENT</b></p>  <p><b>RISQUE D'EXPLOSION</b></p> <ul style="list-style-type: none"> <li>Couper le courant ou s'assurer que l'environnement est classé non dangereux avant de débrancher l'équipement.</li> <li>Couper le courant ou s'assurer que l'environnement est classé non dangereux avant de débrancher les connecteurs. Fixer tous les connecteurs externes reliés à cet équipement à l'aide de vis, loquets coulissants, connecteurs filetés ou autres moyens fournis avec ce produit.</li> <li>La substitution de composants peut rendre cet équipement inadapté à une utilisation en environnement de Classe I, Division 2.</li> <li>S'assurer que l'environnement est classé non dangereux avant de changer les piles.</li> </ul>

---

## Additional Manuals

This product has the following manuals:

- *Logix5000 Controllers Common Procedures*, publication 1756-PM001
- *Logix5000 Controllers General Instructions Reference Manual*, publication 1756-RM003
- *ControlLogix System User Manual*, publication 1756-UM001

---

<b>If you want to:</b>	<b>Then:</b>
view a manual	Visit either of these locations:
download a manual	<ul style="list-style-type: none"><li>• <a href="http://www.ab.com/manuals">www.ab.com/manuals</a></li><li>• <a href="http://www.theautomationbookstore.com">www.theautomationbookstore.com</a></li></ul>
purchase a printed manual	Use one of these options: <ul style="list-style-type: none"><li>• contact your local distributor or Rockwell Automation representative</li><li>• visit <a href="http://www.theautomationbookstore.com">www.theautomationbookstore.com</a> and place an order</li><li>• call 800.963.9548 (USA/Canada) or 001.320.725.1574 (outside USA/Canada)</li></ul>

---

## Rockwell Automation Support

Rockwell Automation provides technical information on the web to assist you in using our products. At <http://support.rockwellautomation.com>, you can find technical manuals, a knowledge base of FAQs, technical and application notes, sample code and links to software service packs, and a MySupport feature that you can customize to make the best use of these tools.

For an additional level of technical phone support for installation, configuration and troubleshooting, we offer TechConnect Support programs. For more information, contact your local distributor or Rockwell Automation representative, or visit <http://support.rockwellautomation.com>.

## Installation Assistance

If you experience a problem with a hardware module within the first 24 hours of installation, please review the information that's contained in this manual. You can also contact a special Customer Support number for initial help in getting your module up and running:

United States	1.440.646.3223 Monday – Friday, 8am – 5pm EST
Outside United States	Please contact your local Rockwell Automation representative for any technical support issues.

## New Product Satisfaction Return

Rockwell tests all of our products to ensure that they are fully operational when shipped from the manufacturing facility. However, if your product is not functioning and needs to be returned:

United States	Contact your distributor. You must provide a Customer Support case number (see phone number above to obtain one) to your distributor in order to complete the return process.
Outside United States	Please contact your local Rockwell Automation representative for return procedure.

[www.rockwellautomation.com](http://www.rockwellautomation.com)

### Corporate Headquarters

Rockwell Automation, 777 East Wisconsin Avenue, Suite 1400, Milwaukee, WI, 53202-5302 USA, Tel: (1) 414.212.5200, Fax: (1) 414.212.5201

### Headquarters for Allen-Bradley Products, Rockwell Software Products and Global Manufacturing Solutions

Americas: Rockwell Automation, 1201 South Second Street, Milwaukee, WI 53204-2496 USA, Tel: (1) 414.382.2000, Fax: (1) 414.382.4444

Europe: Rockwell Automation SA/NV, Vorstaan/Boulevard du Souverain 36-BP 3A/B, 1170 Brussels, Belgium, Tel: (32) 2 663 0600, Fax: (32) 2 663 0640

Asia Pacific: Rockwell Automation, 27/F Citicorp Centre, 18 Whitfield Road, Causeway Bay, Hong Kong, Tel: (852) 2887 4788, Fax: (852) 2508 1846

### Headquarters for Dodge and Reliance Electric Products

Americas: Rockwell Automation, 6040 Ponders Court, Greenville, SC 29615-4617 USA, Tel: (1) 864.297.4800, Fax: (1) 864.281.2433

Europe: Rockwell Automation, Brühlstraße 22, D-74834 Elztal-Dallau, Germany, Tel: (49) 6261 9410, Fax: (49) 6261 17741

Asia Pacific: Rockwell Automation, 55 Newton Road, #11-01/02 Revenue House, Singapore 307987, Tel: (65) 351 6723, Fax: (65) 355 1733

Publication 1756-IN576B-EN-P - September 2003

PN 957707-29

Supersedes Publication 1756-IN576A-EN-P - December 2001

Copyright © 2003 Rockwell Automation, Inc. All rights reserved. Printed in the U.S.A.