

SIEMENS

Supplement to the Operating Instructions for

SIMOREG DC-MASTER Control Module Series 6RA70

Version 07 Order no. 6RX1700-0BD76

for Software Release 3.2



Control Module software version:

As these Operating Instructions went to print, SIMOREG DC-MASTER Control Modules were being delivered from the factory with software version **3.2** installed.

These Operating Instructions also apply to other software versions.

Earlier software versions: Some parameters described in this document might not be stored in the software (i.e. the corresponding functionality is not available on the converter) or some parameters will have a restricted setting range. If this is the case, however, appropriate reference to this status will be made in the Parameter List.

Later software versions: Additional parameters might be available on the SIMOREG DC-MASTER Control Module (i.e. extra functions might be available which are not described in these Operating Instructions) or some parameters might have an extended setting range. In this case, leave the relevant parameters at their factory setting, or do not set any parameter values which are not described in these Instructions !

The software version of the SIMOREG DC-MASTER Control Module can be read in parameters r060 and r065.

The latest software version is available at the following Internet site:

<http://support.automation.siemens.com/WW/view/en/10804967/133100>

CAUTION

Before updating your software, find out the product state of your SIMOREG device. You will find this on the rating plate (field on the bottom left-hand side "Prod. State").

Prod. State = A1,A2 (devices with the CUD1 electronics board, version C98043-A7001-L1-xx):
It is only permissible to load software versions 1.xx and 2.xx.

Prod. State = A3 (devices with the CUD1 electronics board, version C98043-A7001-L2-xx):
It is only permissible to load software versions 3.xx.

Please observe all warnings in the operating instructions for SIMOREG DC-MASTER Control Module.

The reproduction, transmission or use of this document or contents is not permitted without express written authority. Offenders will be liable for damages. All rights, including rights created by patent grant or registration of a utility model or design, are reserved.

We have checked that the contents of this publication agree with the hardware and software described herein. Nonetheless, differences might exist and therefore we cannot guarantee that they are completely identical. The information given in this publication is reviewed at regular intervals and any corrections that might be necessary are made in the subsequent printings. Suggestions for improvement are welcome at all times.

SIMOREG ® is a registered trademark of Siemens

Overview of changes

Chapter 8

Function plans G162 and G195 changed

Chapter 11

r070	Value range changed
P162, P163	Setting range expanded
P185 to P188	New parameters
P192	Setting range expanded
U831	Functionality changed

Chapter 12

K0126, K0127, K0128, K0180	New connectors
B0118, B0119	New binectors

Notes

Download option:

- Changed function plans in dsf (Designer 7) and vsd (VISIO) formats
<http://support.automation.siemens.com/WW/view/en/10804957/133300>
- Update DriveMonitor for software release 3.2
<http://support.automation.siemens.com/WW/view/en/10804957/133100>

For additional information, please contact your local Siemens office.

Section 8 – Function diagrams

Sheet G162 Closed-loop armature current control

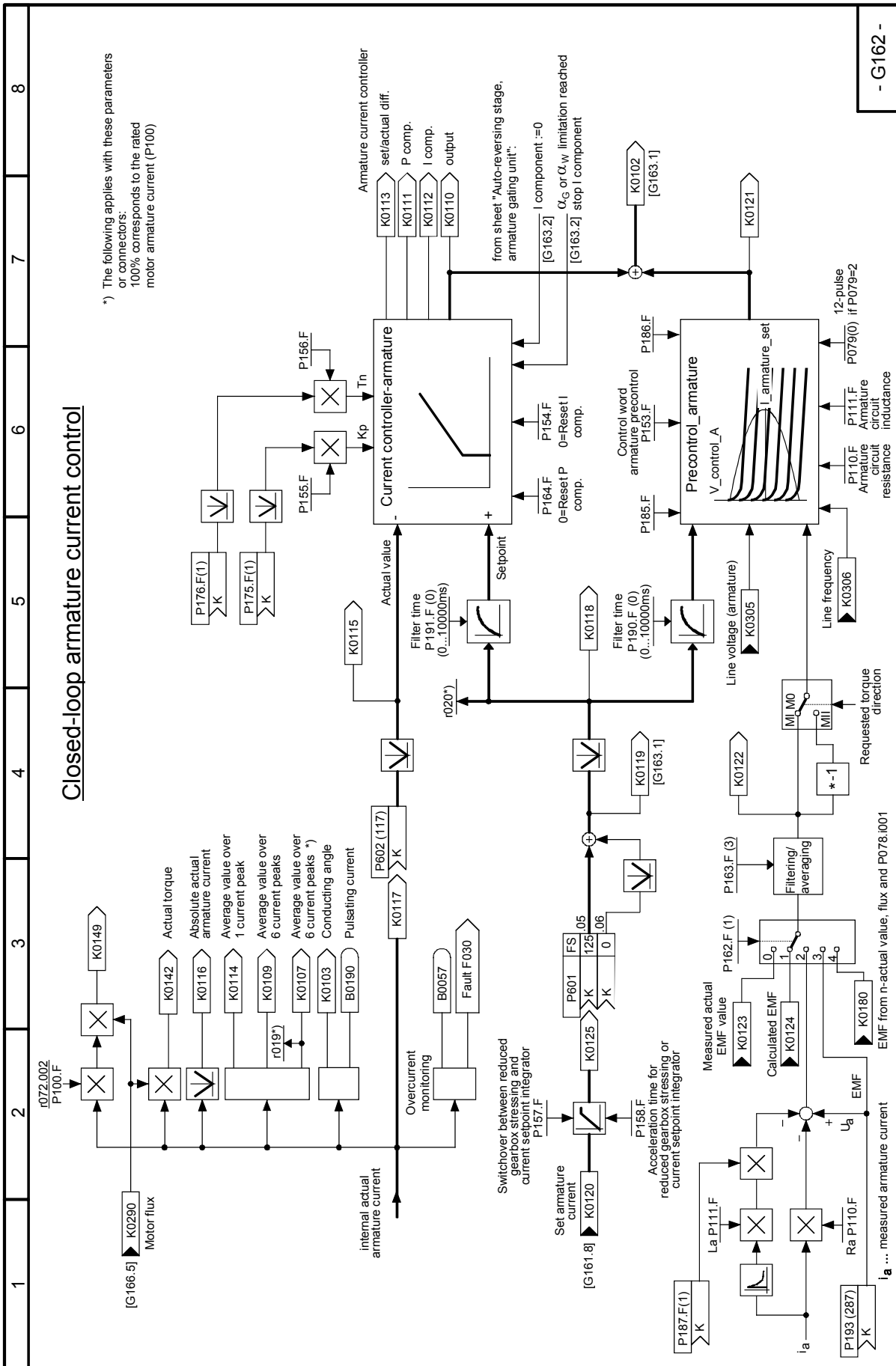

- G162 -

Section 11 – Parameter list

Changed parameters:

PNU	Description	Value range [Unit] Steps	No. indices Factory setting Type	See Change (Access / Status)
r070 (G101)	MLFB (order number) of SIMOREG DC-MASTER converter The corresponding MLFB is displayed in encoded form in this parameter. The MLFB is displayed in plaintext on the OP1S panel.	0 to 138 1	Ind: None Type: O2	P052 = 3
P162 * FDS (G162)	EMF calculation method for armature precontrol 0 The EMF derived from the <u>measured</u> armature voltage (K0123) is applied 1 The EMF derived from the <u>calculated</u> armature voltage (K0124) is applied (the purpose of this setting is to prevent the occurrence of any low-frequency (< 15 Hz) armature current fluctuations) 2 The EMF for armature current precontrol is calculated from the <u>armature voltage selected with P193</u> (the resistive + inductive armature voltage drop is subtracted internally; if P079 = 2, then P110 and P111 only have an effect on half the value) [can only be set in SW 2.1 and later] 3 The <u>connector selected with P193</u> serves as the EMF for armature current precontrol. This setting also facilitates DC link voltage control [can only be set in SW 2.1 and later] 4 [starting from SW 3.2] For armature current precontrol, the actual speed value (unfiltered value K0167), machine flow (K0290, selection via P263), P118, P119 and P078.i001 calculated EMF (K0180) is used. Prerequisite is a recorded field characteristic line. This setting makes sense with 12-pulse parallel operation. It is an advantage when compensated direct current machine is present.	0 to 4 1	Ind: 4 FS=1 Type: O2	P052 = 3 P051 = 40 Offline
P163 * FDS (G162)	EMF filtering method for armature precontrol 0 No filtering 1 Filtering element, filter time constant = half line period (10 ms at 50 Hz line frequency) (for use by works engineers only) 2 Averaging over the last 2 EMF values (for use by works engineers only) 3 Averaging over the last 3 EMF values 4 Filtering element, filter time constant = line period (20 ms at 50 Hz line frequency) [can only be set in SW 2.1 and later] 5 Filtering element, filter time constant = 2 * line period (40 ms at 50 Hz line frequency) [can only be set in SW 2.1 and later] 6 Filtering element, filter time constant = 4 * line period (80 ms at 50 Hz line frequency) [can only be set in SW 2.1 and later] 7 Filtering element, filter time constant = 8 * line period (160 ms at 50 Hz line frequency) [can only be set in SW 2.1 and later] 8 to 12 [starting from SW 3.2] Filter for compensation of the lag of the filter output compared to the input (at linear increase of the input value). Compensation of the lag is limited to $\pm P188$. The filter contains two PT1 elements with filter time constant T_{Filter} , a differentiating element, a limiting element ($\pm P188$) and a summator element. At $P188 = 0.00\%$, the filter acts like a simple PT1 element with the time constant given via P163 T_{Filter} . Note: A PT1 filter element results in a time delay of the output compared to the input by the time constant T_{Filter} . At linear rise $k \cdot t$ of the input dimension, the output lags behind the input by $k \cdot T_{Filter}$. 8 $T_{Filter} = \text{Line period length} / 2$ (10 ms at 50 Hz mains frequency) 9 $T_{Filter} = \text{Line period length}$ (20 ms at 50 Hz mains frequency) 10 $T_{Filter} = 2 \cdot \text{Line period length}$ (40 ms at 50 Hz mains frequency) 11 $T_{Filter} = 4 \cdot \text{Line period length}$ (80 ms at 50 Hz mains frequency) 12 $T_{Filter} = 8 \cdot \text{Line period length}$ (160 ms at 50 Hz mains frequency)	0 to 12 1	Ind: 4 FS=3 Type: O2	P052 = 3 P051 = 40 Offline

New parameters:

PNU	Description	Value range [Unit] Steps	No. indices Factory setting Type	See Change (Access / Status)
P185 * FDS (G163)	Operating mode 6/12 pulse [starting from SW 3.2] 0 6-pulse operation 1 12-pulse parallel operation At P185=1, a precontrol characteristic curve with an additional curvature is effective and L1 is effective for the crossover point from discontinuous to continuous current (is calculated from P111 and P186). P111=L1+La (L1 is the smoothing inductance, including the effective commuting inductance; La is the armature inductance). L1 is effective for the crossover point from discontinuous to continuous current of the precontrol characteristic curve. 2 12-pulse series connection (P079 is to be set correspondingly in addition)	0 to 2 1	Ind: 4 FS=0 Type: O2	P052 = 3 P051 = 40 Offline
P186 FDS (G163)	Inductance factor for 12-pulse parallel operation (L1/La) [starting from SW 3.2] This parameter is only effective at P185=1; it determines the form and – together with P111 – the crossover point from discontinuous to continuous current of the precontrol characteristic curve. The higher the value is set, the closer the form to the 6-pulse characteristic curve.	0.05 to 10.00 0.01	Ind: 4 FS=1,00 Type: O2	P052 = 3 P051 = 40 Online
P187 * FDS (G162) (G165)	Source for evaluation the inductive voltage drop [starting from SW 3.2] The contents of the selected connector act as multiplier for the inductive armature voltage drop in the EMF calculation. The armature voltage drop results from the P111 and the current change.	All connector numbers 1	Ind: 4 FS=1 Type: L2	P052 = 3 P051 = 40 Offline
P188 FDS (G162)	Absolute value of the maximum value of the compensation of the delay of the filtered EMF at P163= 8 to 12 [starting from SW 3.2] This parameter is only effective at P163= 8 to 12. At P163= 8 to 12, the EMF filter compensates for a delay of the filter output compared to the input (at linear rise of the EMF input value) until the amount of the maximum value set at P188. At P188= 0.00%, the filter acts like a simple PT1 element with the time constant given via P163 T _{Filter} . Note: A PT1 filter element results in a time delay of the output compared to the input by the time constant T _{Filter} . At linear rise k*t of the input dimension, the output lags behind the input by k*T _{Filter} . To achieve complete compensation of the delay of the filtered EMF with a linear EMF rise, that value is to be set at P188 at which the EMF changes maximum within a time period of T _{Filter} . At P163= 8 → P188 = max. EMF rise within T _{Filter} = line period/2 At P163= 9 → P188 = max. EMF rise within T _{Filter} = line period At P163= 10 → P188 = max. EMF rise within T _{Filter} = 2* line period At P163= 11 → P188 = max. EMF rise within T _{Filter} = 4* line period At P163= 12 → P188 = max. EMF rise within T _{Filter} = 8* line period Example: The maximum acceleration of the drive from idle to cut-in speed is 800 ms. The EMF thereby increases from 0% to 80% of 1.35*P078.i001. At P163= 10, the filter constant (at 50 Hz mains frequency) is T _{Filter} = 40 ms → P188= 80% * 40 ms / 800 ms = 4.00%	0.00 to 40.00 [%] 0.01%	Ind: 4 FS=5,00 Type: O2	P052 = 3 P051 = 40 Online

Changed parameters:

PNU	Description	Value range [Unit] Steps	No. indices Factory setting Type	See Change (Access / Status)
P192 * FDS (G163)	Control word for the Alpha W limit (armature) [as of SW 2.1] 0 <u>Continuous current:</u> Inverter stability limit for the delay angle of the armature converter (Alpha W) = value according to parameter P151 <u>Intermittent current:</u> Alpha W = 165° 1 Inverter stability limit for the delay angle of the armature converter (Alpha W) = value according to parameter P151 2 Inverter stability limit for the firing angle of the armature current converter (Alpha W) is linear dependent on armature current K0116 [can be set starting from SW 3.1]: K0116 = 0% → Alpha W = 160° (maximum value), K0116 = 100% of r072.i002 → Alpha W = value according to P151, K0116 > 100% of r072.i002 → Alpha W is reduced further linearly [starting from SW 3.2]	0 to 2 1	Ind: 4 FS=0 Type: O2	P052 = 3 P051 = 40 Online
U831 (2831) * (G101)	Fuse monitoring OFF / ON 0 Monitoring OFF 1 Monitoring ON Response of the fuse monitoring causes a fault message F004 with the fault value 3 Starting from SW 3.2, the collective message for the state of fuses is also detectable via the binectors B0118 and B0119 (independent of U831).	0 to 1 1	Ind: None FS=1 Type: O2	P052 = 3 P051 = 40 off-line

Section 12 - List of connectors and binectors

New connectors:

Connector	Description	Normalization	Function diag., Sheet
K0126	Internal armature current actual value (effective value)[starting from SW 3.2]	100% (16384) \triangleq r072.002	
K0127	Armature current actual value (effective value) [starting from SW 3.2]	100% (16384) \triangleq $P078.001 \cdot \frac{3\sqrt{2}}{\pi}$	
K0128	Active power with pure ohmic load [starting from SW 3.2]	100% (16384) \triangleq $r072.002 \cdot P078.001 \cdot \frac{3\sqrt{2}}{\pi}$	
K0180	EMF from n-actual value, flux and P078.i001 [starting from SW 3.2]	100% (16384) \triangleq $P078.001 \cdot \frac{3\sqrt{2}}{\pi}$	

New binectors:

Binector	Name, description	Function diag., Sheet
B0118	1 = fuses OK (collective message; see U831)	[starting from SW 3.2]
B0119	B0118 inverted	[starting from SW 3.2]

