

# Product Information

Original Instructions



**Allen-Bradley**

by ROCKWELL AUTOMATION

## Kinetix 6000 Multi-axis Servo Drives

Catalog Numbers 2094-AC05-MP5-S, 2094-AC05-M01-S, 2094-AC09-M02-S, 2094-AC16-M03-S, 2094-AC32-M05-S, 2094-AMP5-S, 2094-AM01-S, 2094-AM02-S, 2094-AM03-S, 2094-AM05-S, 2094-BC01-MP5-S, 2094-BC01-M01-S, 2094-BC02-M02-S, 2094-BC04-M03-S, 2094-BC07-M05-S, 2094-BMP5-S, 2094-BM01-S, 2094-BM02-S, 2094-BM03-S, 2094-BM05-S



**ATTENTION:** Read this document and the documents listed in the Additional Resources section about installation, configuration and operation of this equipment before you install, configure, operate or maintain this product. Users are required to familiarize themselves with installation and wiring instructions in addition to requirements of all applicable codes, laws, and standards.

Activities including installation, adjustments, putting into service, use, assembly, disassembly, and maintenance are required to be carried out by suitably trained personnel in accordance with applicable code of practice. If this equipment is used in a manner not specified by the manufacturer, the protection provided by the equipment may be impaired.

注意：在安装、配置、操作和维护本产品前，请阅读本文档以及“其他资源”部分列出的有关设备安装、配置和操作的相应文档。除了所有适用规范、法律和标准的相关要求之外，用户还必须熟悉安装和接线说明。

安装、调整、投运、使用、组装、拆卸和维护等各项操作必须由经过适当训练的专业人员按照适用的操作规范实施。

如果未按照制造商指定的方式使用该设备，则可能会损害设备提供的保护。

**ATENCIÓN:** Antes de instalar, configurar, poner en funcionamiento o realizar el mantenimiento de este producto, lea este documento y los documentos listados en la sección Recursos adicionales acerca de la instalación, configuración y operación de este equipo. Los usuarios deben familiarizarse con las instrucciones de instalación y cableado y con los requisitos de todos los códigos, leyes y estándares vigentes.

El personal debidamente capacitado debe realizar las actividades relacionadas a la instalación, ajustes, puesta en servicio, uso, ensamblaje, desensamblaje y mantenimiento de conformidad con el código de práctica aplicable. Si este equipo se usa de una manera no especificada por el fabricante, la protección provista por el equipo puede resultar afectada.

**ATENÇÃO:** Leia este e os demais documentos sobre instalação, configuração e operação do equipamento que estão na seção Recursos adicionais antes de instalar, configurar, operar ou manter este produto. Os usuários devem se familiarizar com as instruções de instalação e fiação além das especificações para todos os códigos, leis e normas aplicáveis.

É necessário que as atividades, incluindo instalação, ajustes, colocação em serviço, utilização, montagem, desmontagem e manutenção sejam realizadas por pessoal qualificado e especializado, de acordo com o código de prática aplicável.

Caso este equipamento seja utilizado de maneira não estabelecida pelo fabricante, a proteção fornecida pelo equipamento pode ficar prejudicada.

**ВНИМАНИЕ:** Перед тем как устанавливать, настраивать, эксплуатировать или обслуживать данное оборудование, прочитайте этот документ и документы, перечисленные в разделе «Дополнительные ресурсы». В этих документах изложены сведения об установке, настройке и эксплуатации данного оборудования. Пользователи обязаны ознакомиться с инструкциями по установке и прокладке соединений, а также с требованиями всех применимых норм, законов и стандартов.

Все действия, включая установку, наладку, ввод в эксплуатацию, использование, сборку, разборку и техническое обслуживание, должны выполняться обученным персоналом в соответствии с применимыми нормами и правилами.

Если оборудование используется не предусмотренным производителем образом, защита оборудования может быть нарушена.

注意：本製品を設置、構成、稼働または保守する前に、本書および本機器の設置、設定、操作についての参考資料の該当箇所に記載されている文書に目を通してください。ユーザは、すべての該当する条例、法律、規格の要件に加えて、設置および配線の手順に習熟している必要があります。

設置調整、運転の開始、使用、組立て、解体、保守を含む諸作業は、該当する実施規則に従って訓練を受けた適切な作業員が実行する必要があります。

本機器が製造メーカーにより指定されていない方法で使用されている場合、機器により提供されている保護が損なわれる恐れがあります。

**ACHTUNG:** Lesen Sie dieses Dokument und die im Abschnitt „Weitere Informationen“ aufgeführten Dokumente, die Informationen zu Installation, Konfiguration und Bedienung dieses Produkts enthalten, bevor Sie dieses Produkt installieren, konfigurieren, bedienen oder warten. Anwender müssen sich neben den Bestimmungen aller anwendbaren Vorschriften, Gesetze und Normen zusätzlich mit den Installations- und Verdrahtungsanweisungen vertraut machen.

Arbeiten im Rahmen der Installation, Anpassung, Inbetriebnahme, Verwendung, Montage, Demontage oder Instandhaltung dürfen nur durch ausreichend geschulte Mitarbeiter und in Übereinstimmung mit den anwendbaren Ausführungsvorschriften vorgenommen werden.

Wenn das Gerät in einer Weise verwendet wird, die vom Hersteller nicht vorgesehen ist, kann die Schutzfunktion beeinträchtigt sein.

**ATTENTION :** Lisez ce document et les documents listés dans la section Ressources complémentaires relatifs à l'installation, la configuration et le fonctionnement de cet équipement avant d'installer, configurer, utiliser ou entretenir ce produit. Les utilisateurs doivent se familiariser avec les instructions d'installation et de câblage en plus des exigences relatives aux codes, lois et normes en vigueur. Les activités relatives à l'installation, le réglage, la mise en service, l'utilisation, l'assemblage, le démontage et l'entretien doivent être réalisées par des personnes formées selon le code de pratique en vigueur.

Si cet équipement est utilisé d'une façon qui n'a pas été définie par le fabricant, la protection fournie par l'équipement peut être compromise.

주의：본 제품 설치, 설정, 작동 또는 유지 보수하기 전에 본 문서를 포함하여 설치, 설정 및 작동에 관한 참고 자료 섹션의 문서들을 반드시 읽고 숙지하십시오. 사용자는 모든 관련 규정, 법규 및 표준에서 요구하는 사항에 대해 반드시 설치 및 배선 지침을 숙지해야 합니다.

설치, 조정, 가동, 사용, 조립, 분해, 유지보수 등 모든 작업은 관련 규정에서 따라 적절한 교육을 받은 사용자를 통해서만 수행해야 합니다.

본 장비를 제조사가 명시하지 않은 방법으로 사용하면 장비의 보호 기능이 손상될 수 있습니다.

**ATTENZIONE:** Prima di installare, configurare ed utilizzare il prodotto, o effettuare interventi di manutenzione su di esso, leggere il presente documento ed i documenti elencati nella sezione "Altre risorse", riguardanti l'installazione, la configurazione ed il funzionamento dell'apparecchiatura. Gli utenti devono leggere e comprendere le istruzioni di installazione e cablaggio, oltre ai requisiti previsti dalle leggi, codici e standard applicabili.

Le attività come installazione, regolazioni, utilizzo, assemblaggio, disassemblaggio e manutenzione devono essere svolte da personale adeguatamente addestrato, nel rispetto delle procedure previste. Qualora l'apparecchio venga utilizzato con modalità diverse da quanto previsto dal produttore, la sua funzione di protezione potrebbe venire compromessa.

**DİKKAT:** Bu ürünün kurulumu, yapılandırılması, işletilmesi veya bakımı öncesinde bu dokümanı ve ekipmanın kurulumu, yapılandırılması ve işletimi ile ilgili ilave Kaynaklar bölümünde yer listelenmiş dokümanları okuyun. Kullanıcılar yürürlükteki tüm yönetmelikler, yasalar ve standartların gereksinimlerine ek olarak kurulum ve kablolama talimatlarını da öğrenmek zorundadır.

Kurulum, ayarlama, hizmete alma, kullanma, parçaları birleştirme, parçaları sökme ve bakım gibi aktiviteler sadece uygun eğitimleri almış kişiler tarafından yürürlükteki uygulama yönetmeliklerine uygun şekilde yapılabilir.

Bu ekipman üretici tarafından belirlenmiş amacın dışında kullanılırsa, ekipman tarafından sağlanan koruma bozulabilir.

注意事項：在安装、設定、操作或維護本產品前，請先閱讀此文件以及列於「其他資源」章節中有關安裝、設定與操作此設備的文件。使用者必須熟悉安裝和配線指示，並符合所有法規、法律和標準要求。

包括安裝、調整、交付使用、使用、組裝、拆卸和維護等動作都必須交由已經適當訓練的人員進行，以符合適用的實作法規。

如果將設備用於非製造商指定的用途時，可能會造成設備所提供的保護功能受損。

**POZOR:** Než začnete instalovat, konfigurovat či provozovat tento výrobek nebo provádět jeho údržbu, přečtěte si tento dokument a dokumenty uvedené v části Dodatečné zdroje ohledně instalace, konfigurace a provozu tohoto zařízení. Uživatelé se musejí vedle požadavků všech relevantních vyhlášek, zákonů a norem nutně seznámit také s pokyny pro instalaci a elektrické zapojení.

Činnosti zahrnující instalaci, nastavení, uvedení do provozu, užívání, montáž, demontáž a údržbu musí vykonávat vhodné proškolený personál v souladu s příslušnými prováděcími předpisy.

Pokud se toto zařízení používá způsobem neodpovídajícím specifikaci výrobce, může být narušena ochrana, kterou toto zařízení poskytuje.

**UWAGA:** Przed instalacją, konfiguracją, użytkowaniem lub konserwacją tego produktu należy przeczytać niniejszy dokument oraz wszystkie dokumenty wymienione w sekcji Dodatkowe źródła omawiające instalację, konfigurację i procedury użytkowania tego urządzenia. Użytkownicy mają obowiązek zapoznać się z instrukcjami dotyczącymi instalacji oraz oprzewodowania, jak również z obowiązującymi kodeksami, prawem i normami.

Działania obejmujące instalację, regulację, przekazanie do użytkowania, użytkowanie, montaż, demontaż oraz konserwację muszą być wykonywane przez odpowiednio przeszkolony personel zgodnie z obowiązującym kodeksem postępowania.

Jeśli urządzenie jest użytkowane w sposób inny niż określony przez producenta, zabezpieczenie zapewniane przez urządzenie może zostać ograniczone.

**OBŚ!** Läs detta dokument samt dokumentet, som står listat i avsnittet Övriga resurser, om installation, konfigurering och drift av denna utrustning innan du installerar, konfigurerar eller börjar använda eller utföra underhållsarbete på produkten. Användare måste bekanta sig med instruktioner för installation och kabeldragning, förutom krav enligt gällande koder, lagar och standarder.

Åtgärder som installation, justering, service, användning, montering, demontering och underhållsarbete måste utföras av personal med lämplig utbildning enligt lämpligt bruk.

Om denna utrustning används på ett sätt som inte anges av tillverkaren kan det hända att utrustningens skyddsanordningar försätts ur funktion.

**LET OP:** Lees dit document en de documenten die genoemd worden in de paragraaf Aanvullende informatie over de installatie, configuratie en bediening van deze apparatuur voordat u dit product installeert, configureert, bediend of onderhoudt. Gebruikers moeten zich vertrouwd maken met de installatie en de bedradingsinstructies, naast de vereisten van alle toepasselijke regels, wetten en normen.

Activiteiten zoals het installeren, afstellen, in gebruik stellen, gebruiken, monteren, demonteren en het uitvoeren van onderhoud mogen uitsluitend worden uitgevoerd door hiervoor opgeleid personeel en in overeenstemming met de geldende praktijkregels.

Indien de apparatuur wordt gebruikt op een wijze die niet is gespecificeerd door de fabrikant, dan bestaat het gevaar dat de beveiliging van de apparatuur niet goed werkt.

### Summary of Changes

This manual contains new and updated information as indicated in the following table.

Topic	Page
Updated input power circuit protection specifications by removing a device no longer available.	4

### Additional Resources

These documents contain additional information concerning related products from Rockwell Automation.

Resource	Description
Kinetix Servo Drives Specifications Technical Data, publication <a href="#">KNX-TD003</a>	Provides product specifications for Kinetix® Integrated Motion over EtherNet/IP™, Integrated Motion over sercos interface, EtherNet/IP networking, and component servo-drive families.
Kinetix 6000 Multi-axis Servo Drives User Manual, publication <a href="#">2094-UM001</a>	Provides detailed installation instructions for mounting, wiring, and troubleshooting the Kinetix 6000 drives; and system integration for your drive/motor/actuator combination with a Logix 5000™ controller.
Kinetix 6000M Integrated Drive-Motor System User Manual, publication <a href="#">2094-UM003</a>	Provides information on installing, configuring, startup, troubleshooting, and applications for your Kinetix 6000M integrated drive-motor (IDM) system.
Kinetix Motion Control Selection Guide, publication <a href="#">KNX-SG001</a>	Provides information to help make initial decisions for the motion control products that are best suited for your system requirements.
System Design for Control of Electrical Noise Reference Manual, publication <a href="#">GMC-RM001</a>	Outlines the practices that minimize the possibility of noise-related failures and that comply with noise regulations.
Industrial Automation Wiring and Grounding Guidelines, publication <a href="#">1770-4.1</a>	Provides general guidelines for installing a Rockwell Automation industrial system.
Product Certifications website <a href="http://rok.auto/certifications">rok.auto/certifications</a>	Provides declarations of conformity, certificates, and other certification details.

You can view or download publications at [rok.auto/literature](http://rok.auto/literature).



**ATTENTION:** Identifies information about practices or circumstances that can lead to personal injury or death, property damage, or economic loss. Attentions help you identify a hazard, avoid a hazard, and recognize the consequences.



**SHOCK HAZARD:** Labels may be on or inside the equipment (for example, drive or motor) to alert people that dangerous voltage may be present.

#### IMPORTANT

Identifies information that is critical for successful application and understanding of the product.



**ATTENTION:** Only qualified personnel familiar with servo drives and associated machinery should plan or implement the installation, startup, and subsequent maintenance of the system. Failure to comply can result in personal injury and/or equipment damage.



**ATTENTION:** An incorrectly applied or installed drive can result in component damage or a reduction in product life. Wiring or application errors such as undersizing the motor, incorrect or inadequate AC supply, or excessive surrounding-air temperatures can result in malfunction of the system.



**ATTENTION:** Drive **must not** be installed in an area where the ambient atmosphere contains volatile or corrosive gas, vapors, or dust. If the drive is not going to be installed for a period of time, it must be stored in an area where it will not be exposed to a corrosive atmosphere.

### Determine Mounting Order

Mount the integrated axis module (IAM), axis modules (AM), and IDM power interface modules (IPIM), shunt, and slot-filler modules in the order (left to right) as shown. Mount the axis modules and IPIM modules according to power utilization (highest to lowest) from left to right starting with the highest power utilization.

Power utilization is the average power (kW) consumed by a servo axis. If Motion Analyzer software was used to size the axis, use the calculated axis power that is required for the power utilization value. If Motion Analyzer software was not used, use the continuous power value (kW) for each module to determine mounting order.

### Module Mounting Order Example

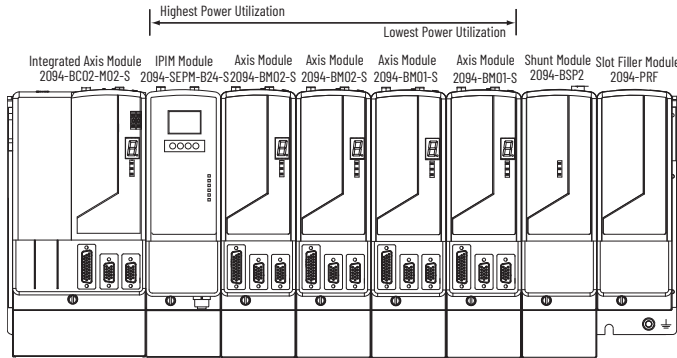

**IMPORTANT** The IAM module must be positioned in the leftmost slot of the power rail. Position your AM/IPIM modules, shunt module, and slot-filler modules to the right of the IAM module. The shunt module must be installed to the right of the last AM/IPIM module. Only slot-filler modules can be installed to the right of the shunt module. Do not mount the shunt module on power rails with a follower IAM module. Common-bus follower IAM modules disable the internal, rail mounted, and external shunt modules.



**SHOCK HAZARD:** To avoid personal injury due to electrical shock, place a 2094-PRF slot-filler module in all empty slots on the power rail. Any power rail connector without a module installed disables the drive system; however, control power is still present.

### Ambient Temperature

Attribute	Operational Range	Storage Range (nonoperating)
Ambient temperature	0...50 °C (32...122 °F)	-40...70 °C (-40...158 °F)

### Weight Specifications

Kinetix 6000 System Component	Cat. No.	Weight, approx kg (lb)	Kinetix 6000 System Component	Cat. No.	Weight, approx kg (lb)
IAM (230V)	2094-AC05-MP5-S	2.23 (4.9)	AM (230V)	2094-AMP5-S	1.46 (3.2)
	2094-AC05-M01-S	2.27 (5.0)		2094-AM01-S	1.50 (3.3)
	2094-AC09-M02-S	2.31 (5.1)		2094-AM02-S	1.54 (3.4)
	2094-AC16-M03-S	4.71 (10.4)		2094-AM03-S	3.13 (6.9)
	2094-AC32-M05-S	7.43 (16.4)		2094-AM05-S	3.18 (7.0)
IAM (460V)	2094-BC01-MP5-S	4.98 (11.0)	AM (460V)	2094-BMP5-S	2.44 (5.4)
	2094-BC01-M01-S	5.03 (11.1)		2094-BM01-S	2.49 (5.5)
	2094-BC02-M02-S	5.08 (11.2)		2094-BM02-S	2.54 (5.6)
	2094-BC04-M03-S	9.60 (21.1)		2094-BM03-S	4.58 (10.1)
	2094-BC07-M05-S	10.1 (22.3)		2094-BM05-S	4.98 (11.0)

### Short Circuit Current Rating

The short-circuit current rating is 200,000 A (rms) symmetrical.

### Branch Circuit Short-circuit Protection

Integral solid-state short circuit protection does not provide branch circuit protection. Branch circuit protection must be provided in accordance with the National Electric Code (NEC) and any additional local codes.

### IAM Module (converter) 200V-class Power Specifications

Attribute	2094-AC05-MP5-S	2094-AC05-M01-S	2094-AC09-M02-S	2094-AC16-M03-S	2094-AC32-M05-S
AC input voltage	195...264V rms three-phase (230V nom)				
DC input voltage (common-bus follower)	275...375V DC				
Control power AC input voltage	95...264V rms single-phase (230V nom)				
Continuous output current to bus ( $A_{dc}$ )	10 A	19 A	36 A	71 A	
Continuous power output to bus	3 kW	6 kW	11.3 kW	22.5 kW	

### IAM Module (converter) 400V-class Power Specifications

Attribute	2094-BC01-MP5-S	2094-BC01-M01-S	2094-BC02-M02-S	2094-BC04-M03-S	2094-BC07-M05-S
AC input voltage	324...528V rms three-phase (360...480V nom)				
DC input voltage (common bus follower)	458...747V DC				
Control power AC input voltage	95...264V rms single-phase (110...240V rms nom)				
Continuous output current to bus ( $A_{dc}$ )	9.0 A	22.6 A	41.5 A	67.7 A	
Continuous power output to bus	6 kW	15 kW	27.6 kW	45 kW	

### AM Module (inverter) 200V-class Power Specifications

Attribute	2094-AMP5-S (2094-AC05-MP5-S)	2094-AM01-S (2094-AC05-M01-S)	2094-AM02-S (2094-AC09-M02-S)	2094-AM03-S (2094-AC16-M03-S)	2094-AM05-S (2094-AC32-M05-S)
Nominal input voltage	325V DC				
Continuous current (rms)	3.7 A	6.0 A	10.6 A	17.3 A	34.6 A
Continuous current (0-pk)	5.2 A	8.5 A	15.0 A	24.5 A	48.9 A
Continuous power out (nom)	1.2 kW	1.9 kW	3.4 kW	5.5 kW	11.0 kW

### AM Module (inverter) 400V-class Power Specifications

Attribute	2094-BMP5-S (2094-BC01-MP5-S)	2094-BM01-S (2094-BC01-M01-S)	2094-BM02-S (2094-BC02-M02-S)	2094-BM03-S (2094-BC04-M03-S)	2094-BM05-S (2094-BC07-M05-S)
Nominal input voltage	650V DC				
Continuous current (rms) <sup>(1)</sup>	2.8 A	6.1 A	10.3 A	21.2 A	34.6 A
Continuous current (sine) 0-pk <sup>(1)</sup>	4.0 A	8.6 A	14.6 A	30.0 A	48.9 A
Continuous power out (nom)	1.8 kW	3.9 kW	6.6 kW	13.5 kW	22.0 kW

(1) Continuous and peak current ratings are for high-speed operation. For constant velocity operation at an electrical output frequency below 5 Hz (75 rpm for 8-pole motors), the output current rating is reduced.

### Motor Overload Protection

This servo drive uses solid-state motor overload protection that operates in accordance with UL requirements. Motor overload protection is provided by algorithms (thermal memory) that predict actual motor temperature based on operating conditions as long as control power is continuously applied. However, when control power is removed, thermal memory is not retained.

In addition to thermal memory protection, this drive provides an input for an external temperature sensor/thermistor device, embedded in the motor, to support the UL requirement for motor overload protection.

Some motors supported by this drive do not contain temperature sensors/thermistors; therefore, motor overload protection against excessive consecutive motor-overloads with power cycling is not supported.

This servo drive meets the following UL requirements for solid-state overload protection.

Motor Overload Protection Trip Point	Value
Ultimately	100% overload
Within 8 minutes	200% overload
Within 20 seconds	600% overload



**ATTENTION:** To avoid damage to your motor due to overheating caused by excessive, successive motor overload trips, follow the wiring diagram provided in the user manual for your motor and drive combination.

Refer to your servo-drive user manual for the interconnect diagram that illustrates the wiring between your motor and drive.

### Control and DC-bus Circuit Protection Specifications

IAM Module Cat. No.	Control Input Power		DC-bus Power	
	Bussmann Fuse <sup>(1)</sup>	Allen-Bradley Circuit Breaker <sup>(2)</sup> (non-UL )	Bussmann Fuse	Mersen Fuse <sup>(3)</sup>
2094-AC05-MP5-S	FNO-R-10 (10 A)	1492-SPM2D060	-	A50P20-1
2094-AC05-M01-S			FWH-35B	A50P35-4
2094-AC09-M02-S			FWH-60B	A50P60-4
2094-AC16-M03-S			FWH-125B	A50P125-4
2094-AC32-M05-S			1492-SPM2D200	
2094-BC01-MP5-S	FNO-R-10 (10 A) or FNO-R-7.5 (7.5 A)	1492-SPM2D060 or 1492-SPM1D150	FWJ-20A14F	DCT20-2
2094-BC01-M01-S			FWJ-40A	A700S40-4
2094-BC02-M02-S			FWJ-70A	A700S70-4
2094-BC04-M03-S			FWJ-125A	A700S125-4
2094-BC07-M05-S				

(1) Use FNO-R-7.5 circuit breaker for higher single -cycle inrush current capability. This is recommended when the continuous control-power current exceeds 3.0 A.  
 (2) Use 1492-SPM1D150 circuit breaker for higher single -cycle inrush current capability. This is recommended when the continuous control-power current exceeds 3.0 A.  
 (3) Mersen fuses were formerly known as Ferraz Shawmut.

### Input Power Circuit Protection Specifications

Kinetix 6000 Drives		UL Applications				IEC (non-UL) Applications		
IAM Module Cat. No.	Drive Voltage (three-phase) nom	Fuses (Bussmann) Cat. No.	Miniature CB Cat. No.	Motor Protection CB, Self-protected CHC Cat. No.	Molded Case CB Cat. No.	Miniature CB Cat. No.	Motor Protection CB Cat. No.	Molded Case CB Cat. No.
2094-AC05-MP5-S	230V	KTK-R-20 (20 A) Class CC	1489-M3D300	140M-F8E-C16	-	1492-SPM3D300	1489-M3D300	140M-F8E-C16
2094-AC05-M01-S	230V	KTK-R-20 (20 A) Class CC		140M-F8E-C16				140M-F8E-C16
2094-AC09-M02-S	230V	KTK-R-30 (30 A) Class CC		140M-F8E-C20				140M-F8E-C20
2094-AC16-M03-S	230V	LPJ-45SP (45 A) Class J	-	-	140G-G6C3-C50	-	-	140G-G6C3-C50
2094-AC32-M05-S	230V	LPJ-80SP (80 A) Class J	-	-	140G-G6C3-C90	-	-	140G-G6C3-C90
2094-BC01-MP5-S	360...480V	KTK-R-20 (20 A) Class CC	1489-M3D300	140M-F8E-C32	-	1492-SPM3D300	1489-M3D300	140M-F8E-C32
2094-BC01-M01-S	360...480V	KTK-R-20 (20 A) Class CC		140M-F8E-C32				140M-F8E-C32
2094-BC02-M02-S	360...480V	KTK-R-30 (30 A) Class CC		140M-F8E-C45				140M-F8E-C45
2094-BC04-M03-S	360...480V	LPJ-45SP (45 A) Class J	-	-	140G-G6C3-C50	-	-	140G-G6C3-C50
2094-BC07-M05-S	360...480V	LPJ-80SP (80 A) Class J	-	-	140G-G6C3-C90	-	-	140G-G6C3-C90

**IMPORTANT** Line interface modules (catalog numbers 2094-ALxxS, 2094-BLxxS, and 2094-XL75S-Cx) can provide branch circuit protection to the IAM module. Follow all applicable NEC and local codes.

## Power Wiring Requirements

Wire should be copper with 75 °C (167 °F) minimum rating. Phasing of main AC power is arbitrary and earth ground connection is required for safe and proper operation.

**IMPORTANT** The National Electrical Code and local electrical codes take precedence over the values and methods provided.

## IAM Power Wiring Requirements

Kinetix 6000 Drive Cat. No.	Description	Connects to Terminals		Recommended Wire Size mm <sup>2</sup> (AWG)	Strip Length mm (in.)	Torque Value N·m (lb·in)			
		Pin	Signal						
2094-AC05-Mxx-S	DC bus (1) and VAC input power	IPD-1 IPD-2 IPD-3 IPD-4 IPD-5 IPD-6	DC- DC+ $\frac{1}{2}$ $\frac{1}{3}$ L2 L1	6...2.5 (10...14)	10 (0.38)	0.5...0.6 (4.4...5.3)			
2094-AC09-M02-S				6...4 (10...12)					
2094-AC16-M03-S				30...10 (3...8)	16 (0.63)	2.4...3.0 (21.6...26.5)			
2094-AC32-M05-S				30 (3)					
2094-BC01-Mxx-S				2094-BC02-M02-S	2094-BC04-M03-S	2094-BC07-M05-S	10...2.5 (8...14)	10 (0.38)	1.2...1.5 (10.6...13.2)
2094-BC04-M03-S							10...6 (8...10)		
2094-BC07-M05-S							30 (3)		
2094-xCxx-Mxx-S				Control input power	CPD-1	CTRL 2	4...2.5 (12...14)	10 (0.38)	0.5...0.6 (4.4...5.3)
	CPD-2	CTRL 1							
	Contactor Enable	CED-1	CONT EN-	4...2.5 (12...14) <sup>(2)</sup>	0.5...0.6 (4.4...5.3)				
		CED-2	CONT EN+						

(1) DC common-bus connections (leader IAM to follower IAM module) should be kept as short as possible.  
 (2) The actual gauge of the contactor enable wiring depends on the system configuration. Consult your machine builder, the NEC, and applicable local codes.



**ATTENTION:** To avoid personal injury and/or equipment damage, make sure that installation complies with specifications regarding wire types, conductor sizes, branch circuit protection, and disconnect devices. The National Electrical Code (NEC) and local codes outline provisions for safely installing electrical equipment.

- To avoid personal injury and/or equipment damage, make sure that motor power connectors are used for connection purposes only. Do not use them to turn the unit on and off.
- To avoid personal injury and/or equipment damage, make sure that shielded power cables are grounded to prevent potentially high voltages on the shield.

## Leakage Current

- Kinetix 6000 drives produce leakage current in the protective-earth conductor that exceeds 3.5 mA AC and/or 10 mA DC. The minimum size of the protective-earth (grounding) conductor used in the application must comply with local safety regulations for high protective-earth conductor current equipment.
- Kinetix 6000 drives produce DC current in the protective earthing conductor and can reduce the ability of a residual current device (RCD) or residual current monitor (RCM) of type A or AC to provide protection for the drive and other equipment in the installation.

## IAM/AM Power Wiring Requirements

Kinetix 6000 Drive Cat. No.	Description	Connects to Terminals		Recommended Wire Size mm <sup>2</sup> (AWG)	Strip Length mm (in.)	Torque Value N·m (lb·in)
		Pin	Signal			
2094-AC05-Mxx-S, 2094-AC09-M02-S, 2094-BC01-Mxx-S, 2094-BC02-M02-S, 2094-AMP5-S, 2094-AM01-S, 2094-AM02-S, 2094-BMP5-S, 2094-BM01-S, 2094-BM02-S	Motor power	MP-4 MP-3 MP-2 MP-1	$\frac{1}{2}$ W V U	Motor power cable depends on motor/drive combination.	10 (0.38)	0.5...0.6 (4.4...5.3)
6...1.5 (10...16)						
2094-AC16-M03-S, 2094-AC32-M05-S, 2094-BC04-M03-S, 2094-AM03-S, 2094-AM05-S, 2094-BM03-S				10...1.5 (8...16)	10 (0.38)	1.2...1.5 (10.6...13.2)
2094-BC07-M05-S, 2094-BM05-S				30...2.5 (3...14)	16 (0.63)	2.4...3.0 (21.6...26.5)
IAM or AM (230 or 460V) 2094-xCxx-Mxx-S and 2094-xMxx-S	Brake power	BC-6 BC-5 BC-4 BC-3 BC-2 BC-1	MBRK- MBRK+ COM PWR DBRK- DBRK+	0.75 (18)	10 (0.38)	0.22...0.25 (1.9...2.2)
IAM or AM (230 or 460V) 2094-xCxx-Mxx-S and 2094-xMxx-S	Safe Torque-off	STO-1 STO-2 STO-3 STO-4 STO-5 STO-6 STO-7 STO-8 STO-9	FDBK2+ FDBK2- FDBK1+ FDBK1- SAFETY ENABLE2+ SAFETY ENABLE- SAFETY ENABLE1+ 24V + 24V_COM	0.75 (18) (stranded wire with ferrule) 1.5 (16) (solid wire)	7.0 (0.275)	0.235 (2.0)

## Kinetix 6000 Drive Connectors

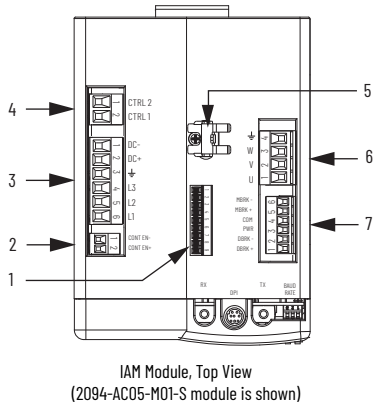

Item	Description
1	Safe Torque-off (STO) connector
2	Contactor enable (CED) connector
3	DC bus/AC input power (IPD) connector
4	Control power (CPD) connector
5	Motor cable shield clamp
6	Motor power (MP) connector
7	Motor/resistive brake (BC) connector

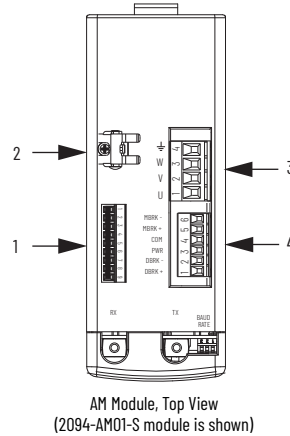

Item	Description
1	Safe Torque-off (STO) connector
2	Motor cable shield clamp
3	Motor power (MP) connector
4	Motor/resistive brake (BC) connector

## Waste Electrical and Electronic Equipment (WEEE)



At the end of life, this equipment should be collected separately from any unsorted municipal waste.

Rockwell Automation maintains current product environmental information on its website at [rok.auto/pec](http://rok.auto/pec).

Your comments help us serve your documentation needs better. If you have any suggestions on how to improve our content, complete the form at [rok.auto/docfeedback](http://rok.auto/docfeedback).

For technical support, visit [rok.auto/support](http://rok.auto/support).

Rockwell Otomasyon Ticaret A.Ş. Kar Plaza İş Merkezi E Blok Kat:6 34752, İçerenköy, İstanbul, Tel: +90 (216) 5698400 EEE Yönetmeliğine Uygundur

Connect with us. 

**rockwellautomation.com** ————— expanding **human possibility**<sup>™</sup>

AMERICAS: Rockwell Automation, 1201 South Second Street, Milwaukee, WI 53204-2496 USA, Tel: (1) 414.382.2000, Fax: (1) 414.382.4444

EUROPE/MIDDLE EAST/AFRICA: Rockwell Automation NV, Pegasus Park, De Kleetlaan 12a, 1831 Diegem, Belgium, Tel: (32) 2 663 0600, Fax: (32) 2 663 0640

ASIA PACIFIC: Rockwell Automation, Level 14, Core F, Cyberport 3, 100 Cyberport Road, Hong Kong, Tel: (852) 2887 4788, Fax: (852) 2508 1846

Allen-Bradley, expanding human possibility, Kinetix, Logix 5000, Rockwell Automation, Rockwell Software are trademarks of Rockwell Automation, Inc.

EtherNet/IP is a trademark of ODVA, Inc.

Trademarks not belonging to Rockwell Automation are property of their respective companies.



PN-584149

Publication 2094-PC003E-EN-P - April 2020 | Supersedes Publication 2094-PC003D-EN-P - August 2015

Copyright © 2020 Rockwell Automation, Inc. All rights reserved. Printed in the U.S.A.