

## 6.1 Function overview and settings

**Sinusoidal current operation is only permissible, if the following components are used:**

Table 6-1 Combination for sinusoidal current operation (regenerative feedback into the line supply)

I/R 16 kW	I/R 36 kW	I/R 55 kW	I/R 80 kW	I/R 120 kW
<b>For internal cooling:</b>	<b>For internal cooling:</b>	<b>For internal cooling:</b>	<b>For internal cooling:</b>	<b>For internal cooling:</b>
6SN1145-1BA01-0BA1	6SN1145-1BA02-0CA1	6SN1145-1BA01-0DA1	6SN1145-1BB00-0EA1	6SN1145-1BB00-0FA1
<b>For external cooling:</b>	<b>For external cooling:</b>	<b>For external cooling:</b>	<b>For external cooling:</b>	<b>For external cooling:</b>
6SN1146-1BB01-0BA1	6SN1146-1BB02-0CA1	6SN1146-1BB00-0DA1	6SN1146-1BB00-0EA1	6SN1146-1BB00-0FA1
<b>HF reactor 16 kW</b>	<b>HF reactor 36 kW</b>	<b>HF reactor 55 kW</b>	<b>HF reactor 80 kW</b>	<b>HF reactor 120 kW</b>
6SN1111-0AA00-0BA1	6SN1111-0AA00-0CA1	6SN1111-0AA00-0DA1	6SN1111-0AA00-1EA0	6SN1111-0AA00-1FA0
<b>Line filter for sinusoidal current<sup>1)</sup> 16 kW</b>	<b>Line filter for sinusoidal current<sup>1)</sup> 36 kW</b>	<b>Line filter for sinusoidal filter<sup>1)</sup> 55 kW</b>	<b>Line filter for sinusoidal current<sup>1)</sup> 80 kW</b>	<b>Line filter for sinusoidal current<sup>1)</sup> 120 kW</b>
6SN1111-0AA01-2BA0	6SN1111-0AA01-2CA0	6SN1111-0AA01-2DA0	6SN1111-0AA01-2EA0	6SN1111-0AA01-2FA0
<p><b>Line supply filter packages</b> are available for the I/R modules. These line filter packages comprise a line supply filter and an HF commutating reactor. If non-certified/authorized components are used, then it is possible that the certificate, issued for this equipment, no longer applies and that these components represent a potential hazard. Adapter sets are available to adapt the line supply filter packages to the mounting surface and to the retaining points of the previous filter modules (Order No., refer to Catalog NC 60)</p>				

**Caution**

It is only permissible to set squarewave current operation for all of the combinations which are not listed here (discontinued filter module 6SN11 11-0AA01-0\_A\_).

For all other operating modes, there is a danger of thermal overload.

Table 6-2 Power factor

I/R	Line-side sinusoidal current operation	$\cos \varphi \approx 0.98$	$\cos \lambda = 0.97$
I/R	Line-side squarewave current operation	$\cos \varphi \approx 0.98$	$\cos \lambda = 0.89$
UI		$\cos \varphi \approx 0.87$	$\cos \lambda = 0.67$

$\cos \varphi$ : The power factor only includes the basic fundamental

$\cos \lambda$ : Power factor includes the basic fundamental and harmonic components

<sup>1)</sup> The HF commutating reactor must be externally mounted. (refer to Section 7.1.3).  
The line filter is required in order to achieve the CE Conformance for the radio interference voltage.

## 6.2 Power modules operated from an uncontrolled infeed

The drive modules can always be operated from the uncontrolled and controlled infeed modules of the SIMODRIVE 611 drive converter system. The configuring/engineering and power data of this Planning Guide refers to operation with the controlled infeed/regenerative feedback modules. This data, if required, should be corrected when operated from uncontrolled infeed modules.

– Operation of drive modules with PH and 1FE1 motors and induction motors on the uncontrolled infeed

When operating main spindle and induction drive modules from uncontrolled infeeds (UI modules), a lower maximum motor output is available in the upper speed range than when using the infeed/regenerative feedback module.

For the UI module, the following inter-relationship is obtained for the available continuous output as a result of the lower DC link voltage of 490 V (for line supply infeed with 3-ph. 400 V AC – 10%):

If

$$\frac{V_{\text{DC link}}}{1.5 \times V_{\text{N motor}}} < 1$$

then, the max. continuous output is given by:

$$P_{\text{cont.}} = P_{\text{N}} \times \frac{V_{\text{DC link}}}{1.5 \times V_{\text{N motor}}}$$

$V_{\text{DC link}} = 490$  for UI modules

$V_{\text{DC link}} = 600$  for I/R modules

## 6.2 Power modules operated from an uncontrolled infeed

Furthermore, for UI modules, it must be observed that the braking energy does not exceed the pulsed resistor rating:

- 5 kW infeed module
  - 200 W continuous output
  - 10 kW short-time output  
for 120 ms once per 10 s switching cycle without pre-load condition
- Infeed module 10 kW
  - 300 W continuous output
  - 25 kW short-time output  
for 120 ms once per 10 s switching cycle without pre-load condition
- Infeed module 28 kW
  - max. 2 x 300 W continuous output
  - max. 2 x 25 kW short-time output  
for 120 ms once per 10 s switching cycle without pre-load condition
  - or
  - max. 2 x 1.5 kW continuous output
  - max. 2 x 25 kW short-time output  
for 120 ms once per 10 s switching cycle without pre-load condition

For 28 kW UI, the pulsed resistors must be separately ordered and must be externally mounted.

For higher regenerative feedback powers, a separate pulsed resistor module must be used or the regenerative feedback power must be reduced by using longer braking times.

## 6.3 Technical data

Table 6-3 Technical data, I/R modules

Internal cooling External cooling Hose cooling	6SN 1145– 6SN 1146– 6SN 1145–	1BA0.–0BA1 1BB0.–0BA1 –	1BA0.–0CA1 1BB0.–0CA1 –	1BA0.–0DA1 1BB0.–0DA1 1BB0.–0DA1	1BB0.–0EA1 1BB0.–0EA1 1BB0.–0EA1	1BB0.–0FA1 1BB0.–0FA1 1BB0.–0FA1
Infeed: Rated power (S1) Infeed power (S6–40%) Infeed peak power	KW KW KW	16 21 35	36 47 70	55 71 91	80 104 131	120 156 175
Regenerative feed- back: Continuous regenera- tive feedback power Regenerative feedback peak power	KW KW	16 35	36 70	55 91	80 131	120 175
Connection data Voltage Frequency	V Hz	3-ph. 400 V AC –10 % to 3-ph. 480 V AC +6 % 50 to 60 ± 10 %				
Rated current (400V/480V) Input current at 360 V <sub>AC</sub> Input current for (480V; S6–40%) Peak current (400V/480V) Connection cross- section, max.	A A A A mm <sup>2</sup>	27/22.5 30 29.6 59/49.2 16	60.5/50.4 67.3 65.8 117.5/97.9 50	92.5/77.1 103 99.2 153/127.5 95	134/111.7 149 145.8 220/183.3 95	202/168.3 224.5 218.3 294/245 150
Output voltage	V	600 / 625 / 680				
Output current at 600 V <sub>DC</sub> Rated current Output current (480V; S6–40%) Peak current	A A A	22.1 29.2 48.3	50 65 96.7	75.8 98.3 125.8	110.8 144.2 181.7	166.7 216.7 242.5
Module width	mm	100	200	300	300	300
Cooling type Internal cooling External cooling Hose cooling		Internal separately- driven fan Integrated separately- driven fan –	Internal separately- driven fan Integrated separately- driven fan –	Internal sepa- rately-driven fan	Mounted fan	Mounted fan
				Fan assembly and mounted fan required		
				Kit for hosing cooling with fan		
Cooling type Internal cooling External cooling Hose cooling	W W (int./ext.) W (int./ext.)	320 50/270 –	585 50/535 –	745 115/630 115/630	1280 190/1090 190/1090	1950 290/1660 290/1660
Efficiency $\eta$		0.97	0.975	0.977	0.977	0.978
Weights Internal cooling External cooling Hose cooling	kg kg kg	10.5 10.5 –	15.5 15.5 –	26 26 26	26 26 26	29 29 29

## 6.3 Technical data

Table 6-4 Technical data, UI modules

Internal cooling External cooling Hose cooling	6SN 1145– 6SN 1146– 6SN 1145–	– 1AA0.–0AA1 –	1AA0.–0CA0 1AB0.–0CA0 –	1AA0.–0CA0 1AB0.–0CA0 –
Infeed: Rated power (S1) Infeed power (S6–40%) Infeed peak power	KW KW KW	5 6.5 10	10 13 25	28 36 50
Continuous/peak power of the integrated pulsed resistor	KW	0.2/10	0.3/25	–
Connection data: Voltage Frequency	V Hz	3-ph. 400 V AC –10 % up to 3-ph. 480 V AC +6 % 50 to 60 ± 10 %		
Rated current Input current for 360 V <sub>AC</sub> Peak current Connection cross–sec- tion, max.	A A A mm <sup>2</sup>	9.4 12.3 18.8 6	18.2 23.8 38.8 16	48.8 62.5 87.1 50
Output voltage	V	490 to 680 +6 %		
Output current for 650 V <sub>DC</sub> Rated current Output current (S6–40%) Peak current	A A A	7.8 10 15.5	15.4 20 38.8	43.3 55.8 77.5
Module width	mm	50	100	200
Cooling type Internal cooling External cooling Hose cooling		Non–ventilated Non–ventilated –	Universal cooling internal/external –	Internal separately– driven fan Integrated separately– driven fan
Cooling type Internal cooling External cooling Hose cooling	W W (int./ext.) W (int./ext.)	270 270/– –	450 119/331 –	745 90/160 –
Efficiency $\eta$		0.985	0.985	0.985
Weights Internal cooling External cooling Hose cooling	kg kg kg	6.5 6.5 –	9.5 9.5 –	15.5 15.5 –

### 6.3.1 Technical data, line supply infeed modules

#### Supply voltage and frequency

Table 6-5 Supply voltage and frequency

	<b>S1, S4 = OFF</b> <b>V<sub>n</sub> = 3-ph. 400 V AC</b>	<b>S1 = ON</b> <b>V<sub>n</sub> = 3-ph. 415 V AC</b>	<b>S4 = ON</b> <b>V<sub>n</sub> = 3-ph. 480 V AC</b>
NE modules up to $P_n \leq \times 55$ kW I/R modules $P_n = 80/120$ kW Power connection: U1, V1, W1	3-ph. 360...440 V AC 3-ph. 300...360 V AC <sup>1)</sup> 45...65 Hz	3-ph. 373...457 V AC 3-ph. 312...373 V AC <sup>1)</sup> 45...65 Hz	3-ph. 432...509 V AC 3-ph. 408...432 V AC <sup>1)</sup> 55...65 Hz
Coil connection: L1, L2 only for 80 kW and 120 kW	2-ph. 360...457 V AC / 45...53 Hz 2-ph. 400...510 V AC / 57...65 Hz		

#### No ground fault

The cabinet wiring, the motor/encoder feeder cables and the DC link connections should be checked to ensure that there are no ground faults before the equipment is powered-up for the first time.

#### Nominal load duty cycles for NE modules

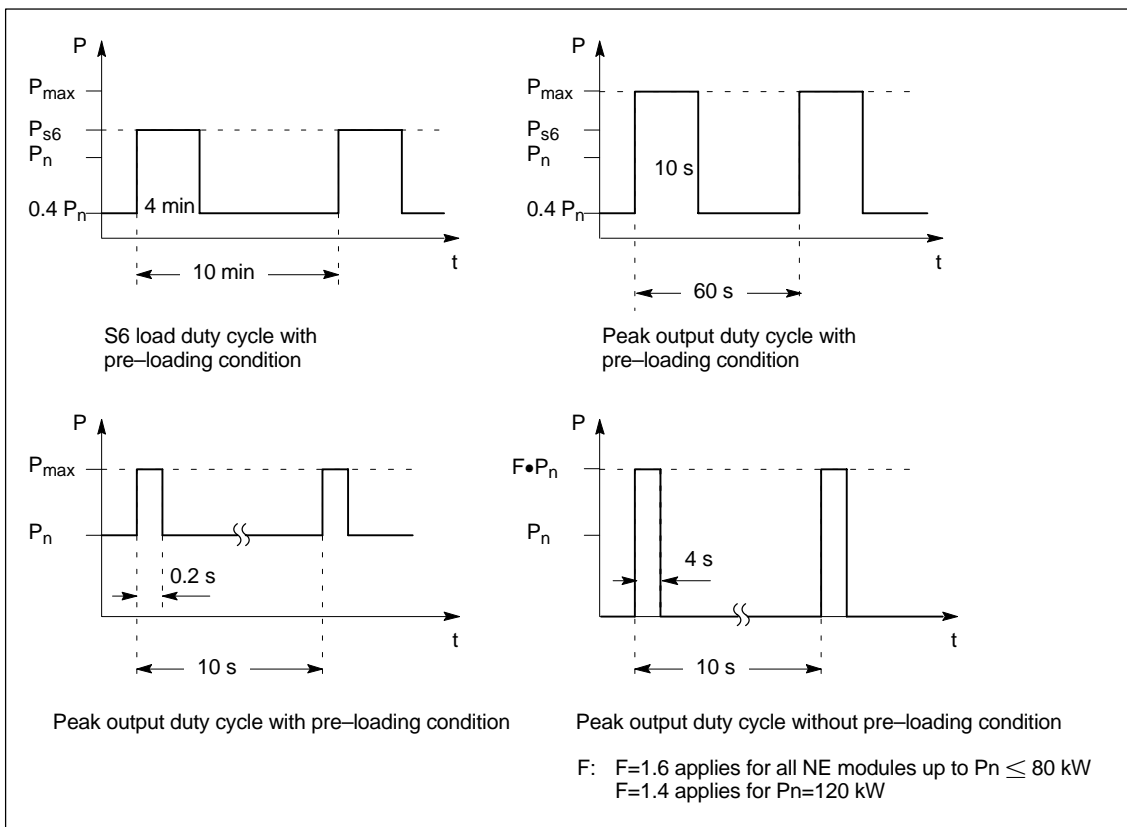

Fig. 6-5 Nominal load duty cycles for NE modules

## 6.3 Technical data

The following rule of thumb is valid:

The following applies for load duty cycles with a period duration  $T \leq 10$  s:

$$\sqrt{\frac{1}{T} \int_0^T \left( \frac{P(t)}{P_n} \right)^2 dt} < 1.03; \quad P_n < P(t) \leq P_{\max}; \quad \tau \in [0, T]$$

The following applies for load duty cycles with a period duration  $10 \text{ s} < T \leq 1 \text{ min}$ :

$$\sqrt{\frac{1}{T} \int_0^T \left( \frac{P(t)}{P_n} \right)^2 dt} < 0.90; \quad P_n < P(t) \leq P_{\max}; \quad \tau \in [0, T]$$

The following applies for load duty cycles with a period duration  $1 \text{ min} < T \leq 10 \text{ min}$ :

$$\sqrt{\frac{1}{T} \int_0^T \left( \frac{P(t)}{P_n} \right)^2 dt} < 0.89; \quad P_n < P(t) \leq P_{\max}; \quad \tau \in [0, T]$$

$P(t)$  = the power presently drawn

### De-rating dependent on the installation altitude

All of the specified outputs are valid up to 1000 m above sea level. For an installation altitude  $> 1000$  m, the specified outputs should be reduced according to the diagrams below. For installation altitudes  $> 2000 \text{ m}^1$  an isolating transformer must be used.

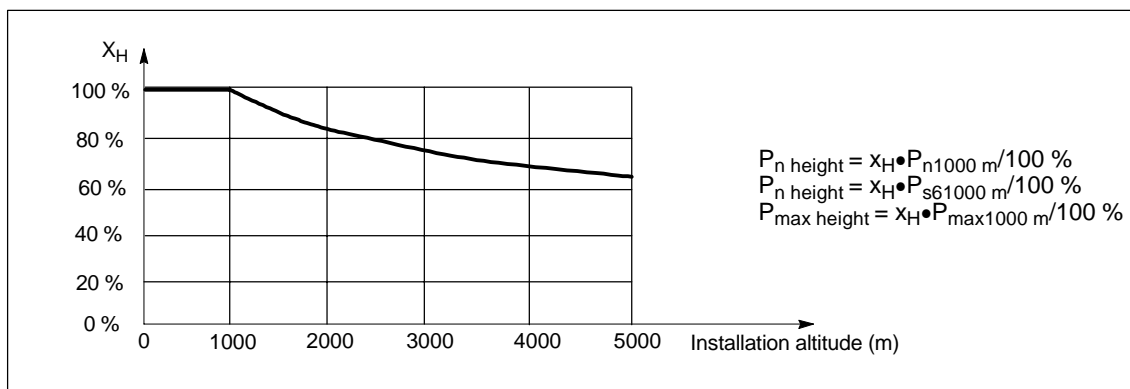

Fig. 6-6 De-rating depends on the installation altitude

Caution:  $P_n$ ,  $P_{s6}$  and  $P_{\max}$  must be de-rated in the same way.

### Note

For the UI module, it must be observed that the braking energy applied to the braking resistor does not exceed the rating of the pulsed resistor.

A defect does not occur, the resistor is switched-out when an overload condition develops.

The unit goes into a fault condition with the "DC link overvoltage" fault.

### 6.3.2 Technical data of the supplementary components

#### Cooling components

Components	Component Order No.	Supply voltage	Supply current	Observe phase sequence!	Degr. of protection	Weight [kg]
Mounted fan for internal and external cooling	6SN1162-0BA02-0AA□	3-ph. 360 to 510 VAC 45 to 65 Hz	0.2 A to 0.3 A	Direction of rotation refer to the arrow on the fan	IP 44	4
Hose cooling package for an individual module comprising: 2x module connecting flange, hose 2000 mm 1x cabinet connecting flange 1x radial fan with cabinet connecting flange <sup>1)</sup> (refer to Fig. 2-4)	6SN1162-0BA03-0AA□	3-ph. 360 to 457 VAC 47.5 to 62.5 Hz	1.0 A +20%	Ccw direction of rot. when viewing the rotor	IP 54	8
Hose cooling package for 2-tier configuration of I/R 55 kW and PM 85 A comprising: 4x module connecting flange, hose 2000 mm 1x cabinet connecting flange 1x radial fan with cabinet connecting flange <sup>1)</sup> (refer to Fig. 2-4)	6SN1162-0BA03-0CA□	3-ph. 360 to 457 VAC 47.5 to 62.5 Hz	1.0 A +20%	Ccw direction of rot. when viewing the rotor	IP 54	8
Motor protection circuit-breaker	Size S00: Setting value 0.3 A Setting value 1 A  Quantity S0 Setting value 0.3 A Setting value 1 A		3RV1011-0DA10 0.22-0.32 A 3RV1011-0KA10 0.9-1.25 A  3RV1021-0DA10 0.22-0.32 A 3RV1011-0KA10 0.9-1.25 A			
Hot air deflection plate	6SN1162-0BA01-0AA0	Required for UI and pulsed-resistor modules when the pulsed resistor is utilized to its maximum ( > 200 W ) (refer to Section 13, dimension drawings)				

- 1) Replacement filter element: Order No. 8MR 1191-0A0  
Ordering location: Pfannenberg GmbH  
Postfach 80747  
21007 Hamburg



#### Warning

The fan may only be commissioned, if it is electrically connected with the module housing (the PE of the fan is connected via the module housing).



**Caution**

Cooling is not guaranteed when the fan rotates in the incorrect direction (refer to arrow)!

**Connection for three-phase fan**

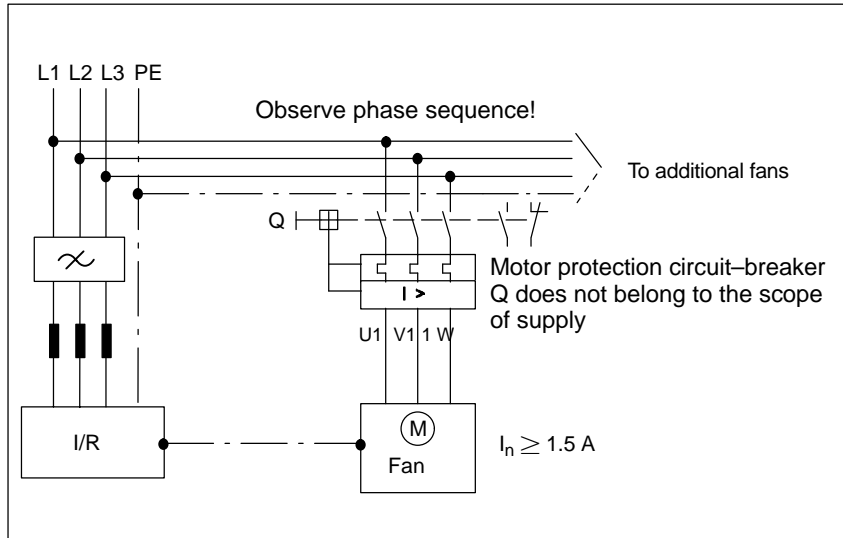

Fig. 6-7 Connection for three-phase fan

## 6.4 Interface overview

### Note

Only PELF or SELF voltages may be connected (refer to EN 60204–1 Section 6.4).

Order Nos. for the coding connector, refer to Catalog NC60.

Only PELV circuits may be connected to terminal 19.

### 6.4.1 Interface overview, NE modules

The interface description is valid for all NE modules with the exception of the 5 kW UI module; this interface has its own description (refer to Section 6.4.2).

Table 6-6 Interface description for NE modules

Term. No.	Desig.	Function	Type <sup>1)</sup>	Typ. voltage/ limit values	Max. cross-section <sup>10)</sup>	Terminals available in <sup>3)</sup>
U1 V1 W1		Supply connection	I	3-ph. 400 V AC	Refer to Section 4.2	I/R, UI
L1 L2		Contactor supply	I I	2-ph. 400 V AC, directly from the supply L1, L2, L3, refer to Sect. 9.2	16 mm <sup>2</sup> /10 mm <sup>2</sup> 4) 16 mm <sup>2</sup> /10 mm <sup>2</sup> 4)	I/R 80 kW, 120 kW
PE P600 M600		Protective conductor DC link DC link	I I/O I/O	0 V +300 V –300 V	Bolt Busbar Busbar	I/R, UI, monitoring module, pulsed resistor
		Grounding bar <sup>5)</sup>	I/O	–300 V	Busbar	I/R, UI
P600 M600		DC link DC link	I/O I/O	+300 V –300 V	16 mm <sup>2</sup> /10 mm <sup>2</sup> 4) 16 mm <sup>2</sup> /10 mm <sup>2</sup> 4)	Monitoring module <sup>11)</sup>
1R, 2R, 3R	TR1, TR2 <sup>9)</sup>	External resistance connection	I/O	V300	6 mm <sup>2</sup> /4 mm <sup>2</sup> 4)	Pulsed resistor; UI 28 kW
	X131	Electronics M	I/O	0 V	16 mm <sup>2</sup> /10 mm <sup>2</sup> 4)	I/R, UI, monitoring module

1) I = input; O = output; NC = NC contact; NO = NO contact; (for signal, NO = high; NC = low)

2) Terminal 19 is the reference ground (connected in the module with 10 kΩ to a general reference ground, X131/terminal 15)

Terminal 15 may neither be connected to PE nor to terminal 19, furthermore, it is not permissible that external voltage sources are connected to terminal 15. Terminal 19 may be connected to terminal X131. The terminal may only be used to enable the associated drive group.

3) I/R = Infeed/regenerative feedback module; UI = Uncontrolled infeed; MM = Monitoring module; PW = Pulse resistor module

4) The 1st number is valid for cable lugs. The 2nd number is valid for finely-stranded conductors without conn. sleeves.

5) The grounding bar is used to ground the DC link M rail through 100 kΩ (this should be preferably inserted; if the system is subject to a high voltage test, the grounding bar should be opened).

6) RESET = reset the fault memory, edge-triggered for the complete drive group (terminal "R" → terminal 15 = RESET)

7) Terminal 111–213 positively-driven NC contact (for I/R 16 kW and UI 10 kW, only from Order No. [MLFB]: 6SN114□–1□□01–0□□□)

Terminals 111–113 NO contact, not positively driven

8) Maximum current load of terminal 9 with respect to 19: 0.5 A.

9) Only for UI 28 kW

10) For UL certification, only use copper cables designed for an operating temperature of  $\geq 60^\circ\text{C}$

11) Max. permissible connection power  $P_{\text{max}} \leq 43 \text{ kW}$

Max. permissible current load  $I_{\text{max}} \leq 72 \text{ A}$

## 6.4 Interface overview

Table 6-6 Interface description for NE modules

Term. No.	Desig.	Function	Type <sup>1)</sup>	Typ. voltage/ limit values	Max. cross-section <sup>10)</sup>	Terminals available in <sup>3)</sup>
	X151	Equipment bus	I/O	Various	Ribbon cable	I/R, UI, monitoring module, pulsed resistor
M500 P500 1U1 2U1 1V1 2V1 1W1 2W1	X181 X181 X181 X181 X181 X181 X181 X181	DC link power supply DC link power supply Output L1 Input L1 Output L2 Input L2 Output L3 Input L3	I I O I O I O I	DC -300 V DC +300 V 3-ph. 400 V AC 3-ph. 400 V AC 3-ph. 400 V AC 3-ph. 400 V AC 3-ph. 400 V AC 3-ph. 400 V AC	1.5 mm <sup>2</sup> 1.5 mm <sup>2</sup> 1.5 mm <sup>2</sup> 1.5 mm <sup>2</sup> 1.5 mm <sup>2</sup> 1.5 mm <sup>2</sup> 1.5 mm <sup>2</sup> 1.5 mm <sup>2</sup>	I/R, UI, monitoring module
7 45 44 10 15 <sup>2)</sup> R <sup>6)</sup>	X141 X141 X141 X141 X141 X141	P24 P15 N15 N24 M RESET	O O O O O I	+20.4...28.8 V/50 mA +15 V/10 mA -15 V/10 mA -20.4...28.8 V/50 mA 0 V Term.15/R <sub>E</sub> = 10 kΩ	1.5 mm <sup>2</sup> 1.5 mm <sup>2</sup> 1.5 mm <sup>2</sup> 1.5 mm <sup>2</sup> 1.5 mm <sup>2</sup> 1.5 mm <sup>2</sup>	I/R, UI, monitoring module
5.3 5.2 5.1 63 <sup>2)</sup> 9 <sup>2)</sup> 8) 9 <sup>2)</sup> 8) 64 <sup>2)</sup> 19	X121 X121 X121 X121 X121 X121 X121	Relay contact Group signal I <sup>2</sup> t/motor temp. Pulse enable Enable voltage Enable voltage Drive enable Enable voltage, reference potential	NC NO I I O O I I	50 V DC/0.5 A/12 VA max 5 V DC/3 mA min +13 V...30 V/R <sub>E</sub> = 1.5 kΩ +24 V +24 V +13 V...30 V/R <sub>E</sub> = 1.5 kΩ 0 V	1.5 mm <sup>2</sup> 1.5 mm <sup>2</sup> 1.5 mm <sup>2</sup> 1.5 mm <sup>2</sup> 1.5 mm <sup>2</sup> 1.5 mm <sup>2</sup> 1.5 mm <sup>2</sup> 1.5 mm <sup>2</sup>	I/R, UI, monitoring module
74 nc 73.2 73.1 nc 72	X111 X111 X111 X111 X111 X111	Relay contact Ready signal	NC I I NO	1-ph. 250 V AC/50 V DC/2 A <sub>max.</sub> 5 V DC/3 mA min	1.5 mm <sup>2</sup> 1.5 mm <sup>2</sup> 1.5 mm <sup>2</sup> 1.5 mm <sup>2</sup> 1.5 mm <sup>2</sup> 1.5 mm <sup>2</sup>	I/R, UI, monitoring module
9 <sup>2)</sup> 8) 112 <sup>2)</sup>	X161 X161	Enable voltage Setting-up mode/ Standard mode	O I	+24 V +21 V...30 V/R <sub>E</sub> = 1.5 kΩ	1.5 mm <sup>2</sup> 1.5 mm <sup>2</sup>	I/R, UI, monitoring module

- 1) I = input; O = output; NC = NC contact; NO = NO contact; (for signal, NO = high; NC = low)
- 2) Terminal 19 is the reference ground (connected in the module with 10 kΩ to a general reference ground, X131/terminal 15)  
Terminal 15 may neither be connected to PE nor to terminal 19, furthermore, it is not permissible that external voltage sources are connected to terminal 15. Terminal 19 may be connected to terminal X131.  
The terminal may only be used to enable the associated drive group.
- 3) I/R = Infeed/regenerative feedback module; UI = Uncontrolled infeed; MM = Monitoring module; PW = Pulse resistor module
- 4) The 1st number is valid for cable lugs. The 2nd number is valid for finely-stranded conductors without conn. sleeves.
- 5) The grounding bar is used to ground the DC link M rail through 100 kΩ (this should be preferably inserted; if the system is subject to a high voltage test, the grounding bar should be opened).
- 6) RESET = reset the fault memory, edge-triggered for the complete drive group (terminal "R" → terminal 15 = RESET)
- 7) Terminal 111-213 positively-driven NC contact (for I/R 16 kW and UI 10 kW, only from Order No. [MLFB]: 6SN114□-1□□01-0□□□)  
Terminals 111-113 NO contact, not positively driven
- 8) Maximum current load of terminal 9 with respect to 19: 0.5 A.
- 9) Only for UI 28 kW
- 10) For UL certification, only use copper cables designed for an operating temperature of ≥ 60°C
- 11) Max. permissible connection power P<sub>max</sub> ≤ 43 kW  
Max. permissible current load I<sub>max</sub> ≤ 72 A

Table 6-6 Interface description for NE modules

Term. No.	Desig.	Function	Type <sup>1)</sup>	Typ. voltage/ limit values	Max. cross-section <sup>10)</sup>	Terminals available in <sup>3)</sup>	
48 <sup>2)</sup> 111 <sup>7)</sup> 213 <sup>7)</sup>	X161 X161 X161	} Signaling contacts	I I NC	+13 V...30 V/R <sub>E</sub> = 1.5 kΩ +30 V/1 A (111–113) 1-ph. 250 V AC/50 V DC/ 2 A max 17 V DC/3 mA min	1.5 mm <sup>2</sup> 1.5 mm <sup>2</sup> 1.5 mm <sup>2</sup>	I/R, UI	
113 <sup>7)</sup>	X161		} Line contactor		NO		1.5 mm <sup>2</sup>
AS1 AS2	X172 X172	Signaling contact Start inhibit (terminal 112)	I NC	250 V AC / 1 A / 50 V DC/ 2A max 5 V DC/10 mA min	1.5 mm <sup>2</sup> 1.5 mm <sup>2</sup>		I/R
NS1 NS2	X171 X171	Coil contact for line, pre-charging contactor	O I	+24 V	1.5 mm <sup>2</sup> 1.5 mm <sup>2</sup>		I/R, UI
19	X221	Enable voltage, reference potential	O	0 V	1.5 mm <sup>2</sup>	Pulsed resistor	
50	X221	Control contact for fast discharge	I	0 V	1.5 mm <sup>2</sup>		

- 1) I = input; O = output; NC = NC contact; NO = NO contact; (for signal, NO = high; NC = low)
- 2) Terminal 19 is the reference ground (connected in the module with 10 kΩ to a general reference ground, X131/terminal 15)  
Terminal 15 may neither be connected to PE nor to terminal 19, furthermore, it is not permissible that external voltage sources are connected to terminal 15. Terminal 19 may be connected to terminal X131.  
The terminal may only be used to enable the associated drive group.
- 3) I/R = Infeed/regenerative feedback module; UI = Uncontrolled infeed; MM = Monitoring module; PW = Pulse resistor module
- 4) The 1st number is valid for cable lugs. The 2nd number is valid for finely-stranded conductors without conn. sleeves.
- 5) The grounding bar is used to ground the DC link M rail through 100 kΩ (this should be preferably inserted; if the system is subject to a high voltage test, the grounding bar should be opened).
- 6) RESET = reset the fault memory, edge-triggered for the complete drive group (terminal "R" → terminal 15 = RESET)
- 7) Terminal 111–213 positively-driven NC contact (for I/R 16 kW and UI 10 kW, only from Order No. [MLFB]: 6SN114□–1□□01–0□□□)  
Terminals 111–113 NO contact, not positively driven
- 8) Maximum current load of terminal 9 with respect to 19: 0.5 A.
- 9) Only for UI 28 kW
- 10) For UL certification, only use copper cables designed for an operating temperature of ≥ 60°C
- 11) Max. permissible connection power P<sub>max</sub> ≤ 43 kW  
Max. permissible current load I<sub>max</sub> ≤ 72 A



### Warning

In order to prevent damage to the infeed circuit of the NE modules, when energizing terminal 50 at X221 (DC link fast discharge), ensure that terminal 48 of the NE module is de-energized (electrically isolated from the line supply). The checkback signal contacts of the main contactor of the NE module must be evaluated (X161 terminal 111, terminal 113, terminal 213).

## 6.4 Interface overview

## 6.4.2 Interface overview, 5 kW UI module

Table 6-7 Interface overview, 5 kW UI module

Term. No.	Desig.	Function	Type 1)	Typ. voltage/limit values	Max. cross-section 6)				
U1 V1 W1	X1	Supply connection	I	3-ph. 400 V AC	4 mm <sup>2</sup> finely stranded without end sleeves 6 mm <sup>2</sup> with cable lug				
PE 	– X131 X351	Protective conductor Electronics M Equipment bus  Grounding bar 3)	I I I/O I/O	0 V 0 V Various –300 V	M5 thread M4 thread 34-core ribbon cable  Busbar				
P600 M600		DC link	I/O	+300 V –300 V	Busbar				
M500 P500 1U1 2U1 1V1 2V1 1W1 2W1	X181 X181 X181 X181 X181 X181 X181 X181	DC link power supply DC link power supply Output L1 Input L1 Output L2 Input L2 Output L3 Input L3	I I O I O I O I	–300 V +300 V 3-ph. 400 V AC 3-ph. 400 V AC 3-ph. 400 V AC 3-ph. 400 V AC 3-ph. 400 V AC 3-ph. 400 V AC	1.5 mm <sup>2</sup> 1.5 mm <sup>2</sup> 1.5 mm <sup>2</sup> 1.5 mm <sup>2</sup> 1.5 mm <sup>2</sup> 1.5 mm <sup>2</sup> 1.5 mm <sup>2</sup> 1.5 mm <sup>2</sup>				
5.3 5.2 5.1 nc	X121A X121A X121A X121A	} Relay contact group signal I <sup>2</sup> t/motor temp.	NC NO I	50 V DC/0.5 A/12 VA max 5 V DC/3 mA min	1.5 mm <sup>2</sup> 1.5 mm <sup>2</sup> 1.5 mm <sup>2</sup> 1.5 mm <sup>2</sup>				
74 73.2 73.1 72	X121B X121B X121B X121B		} Relay signal Ready/fault		NC I I NO	1AC 250 V/DC 50 V/2 A max 1DC 5 V/3 mA min	1.5 mm <sup>2</sup> 1.5 mm <sup>2</sup> 1.5 mm <sup>2</sup> 1.5 mm <sup>2</sup>		
63 <sup>2)</sup> 9 <sup>2)4)</sup> 9 <sup>2)4)</sup> 64 <sup>2)</sup> R <sup>5)</sup> 19	X141AX 141A X141A X141A X141A X141A				Pulse enable FR+ FR+ Drive enable RESET FR, reference ground enable voltage		I O O I I O	+13 V...30 V/R <sub>E</sub> = 1.5 kΩ +24 V +24 V +13 V...30 V/R <sub>E</sub> = 1.5 kΩ term.19/R <sub>E</sub> = 10 kΩ	1.5 mm <sup>2</sup> 1.5 mm <sup>2</sup> 1.5 mm <sup>2</sup> 1.5 mm <sup>2</sup> 1.5 mm <sup>2</sup> 1.5 mm <sup>2</sup>

1) I = input; O = output; NC = NC contact; NO = NO contact

2) Terminal 19 is the reference terminal (connected in the module to 10 kΩ to general reference ground X131)  
Terminal 15 may neither be connected to PE nor to terminal 19, furthermore, it is not permissible that external voltage sources are connected to terminal 15. Terminal 19 may be connected to terminal X131.  
The terminal may only be used to enable the associated drive group.

3) The grounding bar is used to ground the DC link M rail through 100 kΩ (this should be preferably inserted; if the system is subject to a high-voltage test, the grounding bar should be opened).

4) Max. current load of terminal 9 - terminal 19  $\leq 1$  A  
Notice: UI 5 kW does not have terminals 7, 45, 44 and 10.

5) RESET = Reset the fault memory, edge triggered for the complete drive group  
(term. "R" → term. 19 = RESET)

6) For UL certification, only use copper cables designed for an operating temperature of  $\geq 60^\circ\text{C}$

Table 6-7 Interface overview, 5 kW UI module

Term. No.	Desig.	Function	Type <sup>1)</sup>	Typ. voltage/limit values	Max. cross-section <sup>6)</sup>
111 213	X161 X161	} Signaling contact Line contactor	I NC	1-ph. 250 V AC/50 V DC/2 A 17 V DC/3 mA min	1.5 mm <sup>2</sup> 1.5 mm <sup>2</sup>
g <sup>2)</sup> 4)	X141B	FR+	O	+24 V	1.5 mm <sup>2</sup>
112	X141B	Setting-up/normal operation	I	+13 V...30 V/R <sub>E</sub> = 1.5 kΩ	1.5 mm <sup>2</sup>
48	X141B	contactor control	I	+13 V...30 V/R <sub>E</sub> = 1.5 kΩ	1.5 mm <sup>2</sup>
NS1	X141B	} Coil contact for line,	O	+24 V	1.5 mm <sup>2</sup>
NS2	X141B	pre-charging contactor	I	0/+24 V	1.5 mm <sup>2</sup>
15	X141B	M	O	0 V	1.5 mm <sup>2</sup>

1) I = input; O = output; NC = NC contact; NO = NO contact

2) Terminal 19 is the reference terminal (connected in the module to 10 kΩ to general reference ground X131)  
Terminal 15 may neither be connected to PE nor to terminal 19, furthermore, it is not permissible that external voltage sources are connected to terminal 15. Terminal 19 may be connected to terminal X131.

The terminal may only be used to enable the associated drive group.

3) The grounding bar is used to ground the DC link M rail through 100 kΩ (this should be preferably inserted; if the system is subject to a high-voltage test, the grounding bar should be opened).

4) Max. current load of terminal 9 - terminal 19  $\leq$  1 A

Notice: UI 5 kW does not have terminals 7, 45, 44 and 10.

5) RESET = Reset the fault memory, edge triggered for the complete drive group  
(term. "R" → term. 19 = RESET)

6) For UL certification, only use copper cables designed for an operating temperature of  $\geq$  60°C

Notice: UI kW does not have terminals 7, 45, 44 and 10.

#### Note

For UI 5 kW, the DC link is pre-charged via two phases.

If a DC link voltage is not established (there is no ready signal) even if all of the enable signals are present, then a check must be made as to whether all of the three phases are present at terminals U1, V1, W1.