

SPAJ 110 C

Earth-fault relay

User's manual and Technical description

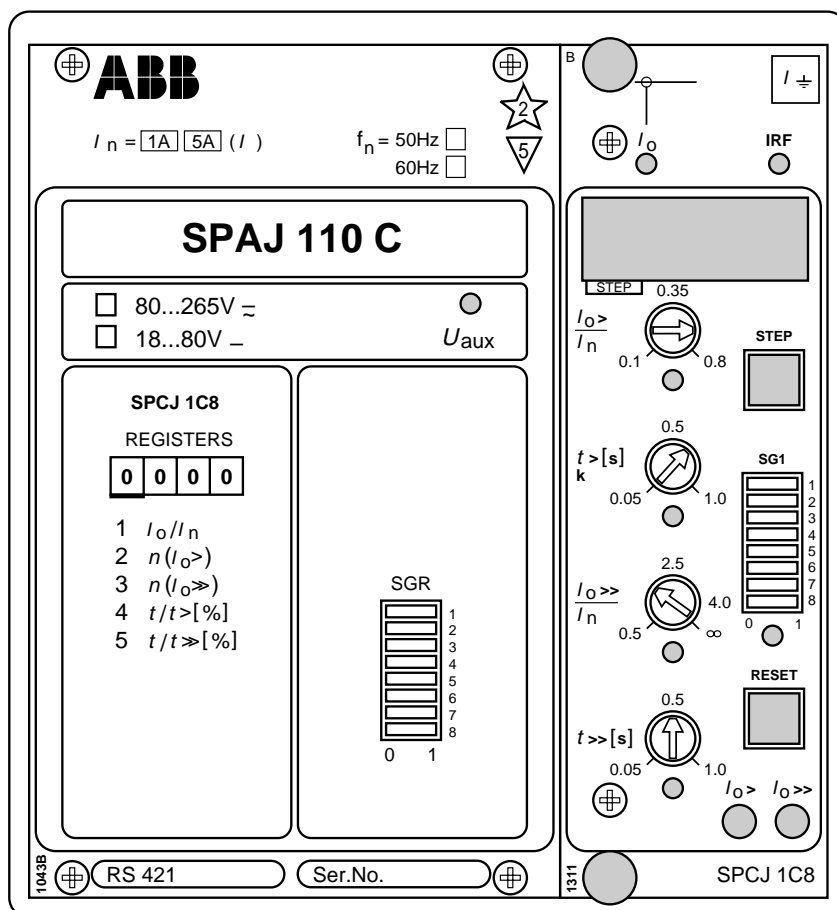

Data subject to change without notice

Contents	Features	2
	Application	2
	Description of operation	3
	Connections	4
	Configuration of output relays	6
	Start and operation indicators	7
	Combined power supply and I/O module	7
	Technical data (<i>modified 2002-04</i>)	8
	Examples of application	10
	Recorded data and fault analysis	14
	Secondary injection testing	14
	Maintenance and repair	18
	Spare parts	18
	Ordering numbers	18
	Dimensions and instructions for mounting	19
	Order information	19

The complete manual for the earth-fault relay SPAJ 110 C includes the following partial manuals:

Earth-fault relay SPAJ 110 C, general part	1MRS 750801-MUM EN
Non-directional earth-fault relay module SPCJ 1C8	1MRS 750603-MUM EN
General characteristics of C-type relay modules	1MRS 750328-MUM EN

Features	Low-set neutral overcurrent stage with definite time or inverse time characteristic	Serial interface for connecting the relay to a fibre optic object bus and substation and network control systems
	High-set neutral overcurrent stage with definite time characteristic	Digital display of setting values, neutral current measured, memorized fault values, etc.
	Output relay functions to be freely configured	Continuous self-supervision with auto-diagnostics of hardware and software
	Flexible adaptation to different types of application	

Application	The earth-fault relay SPAJ 110 C is designed to be used for selective earth-fault protection, either primary or back-up protection, in solidly earthed or low-resistance earthed power systems.	definite-time characteristic or with inverse-time characteristic, while the high-set stage operates with definite time characteristic only. The earth-fault relay is used both as primary and back-up earth-fault protection relay for feeders, transformers, generators and motors. The relay can be configured to cooperate with a residual voltage relay used for blocking/deblocking the operation of the earth-fault relay.
	The relay has two protection stages: a low-set overcurrent stage $I_{0>}$ and a high-set overcurrent stage $I_{0>>}$. The low-set stage operates with	

Description of operation

The earth-fault relay SPAJ 110 C is a secondary relay that is connected to the current transformers of the object to be protected. The earth-fault current can be measured either via a set of three phase current transformers in a residual current connection or a window-type core-balance current transformer. When a core-balance current transformer is used, it should be secured that the repeatability of the current transformer is sufficient also at high earth-fault currents. When an earth-fault occurs, the relay delivers an alarm signal, trips the circuit breaker or starts an external auto-reclose relay, depending on the application and the configuration of the relay.

When the energizing current exceeds the set start value $I_{0>}$ of the low-set stage, the earth-fault relay starts. When, at definite time operation, the set operate time $t_{>}$ or, at IDMT operation, the calculated operate time $t_{>}$, expires, the relay operates. In the same way the high-set stage

starts once its set start value $I_{0>>}$ is exceeded and, when the set operate time $t_{>>}$ expires, the relay operates.

The low-set stage of the earth-fault relay can be given either definite-time or inverse-time characteristic. At inverse time characteristic four inverse time curve sets with different degrees of inversivity are available: Normal inverse, Very inverse, Extremely inverse and Long-time inverse. These curve sets comply with the BS 142 and IEC 60255 standards.

The start signal from the earth-fault relay is received as contact function. The start signal can be used, for instance, for blocking cooperating protection relays.

The relay contains one optically isolated logic input for incoming external control signals, generally blocking signals.

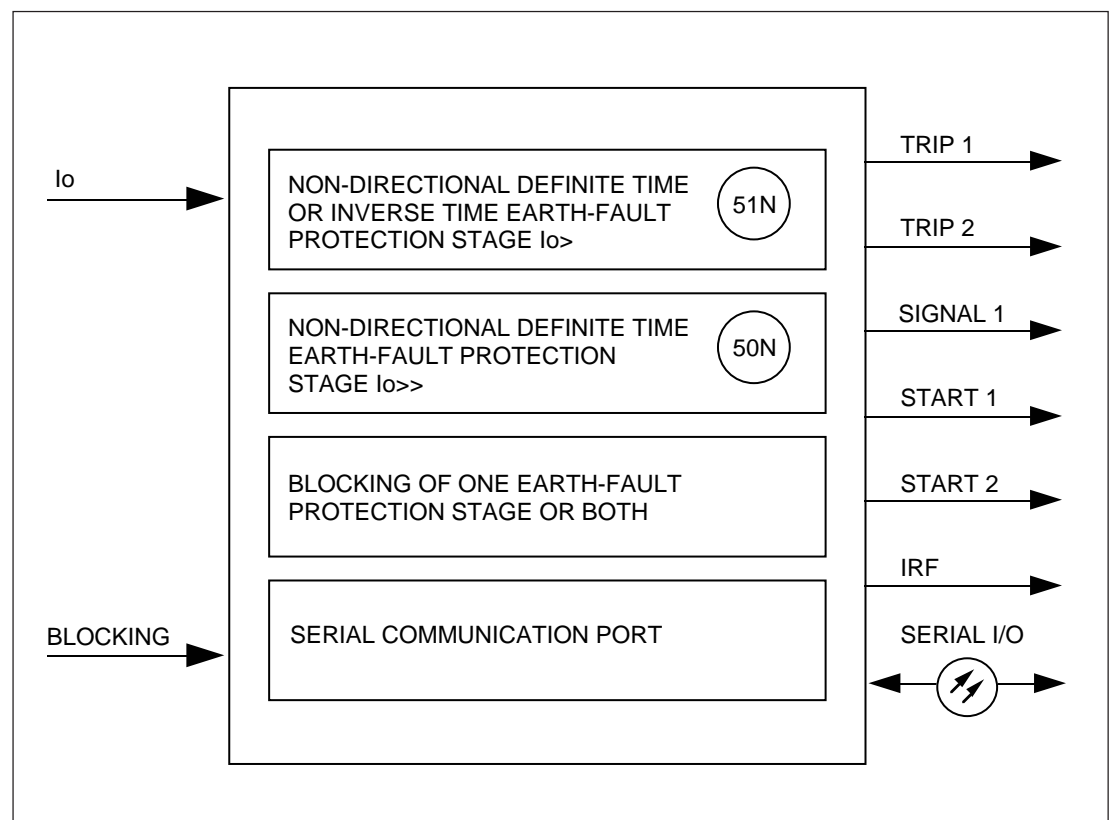

Fig. 1. Protection functions of the earth-fault relay SPAJ 110 C. The encircled numbers refer to the ANSI (=American National Standards Institute) number of the concerned protection function.

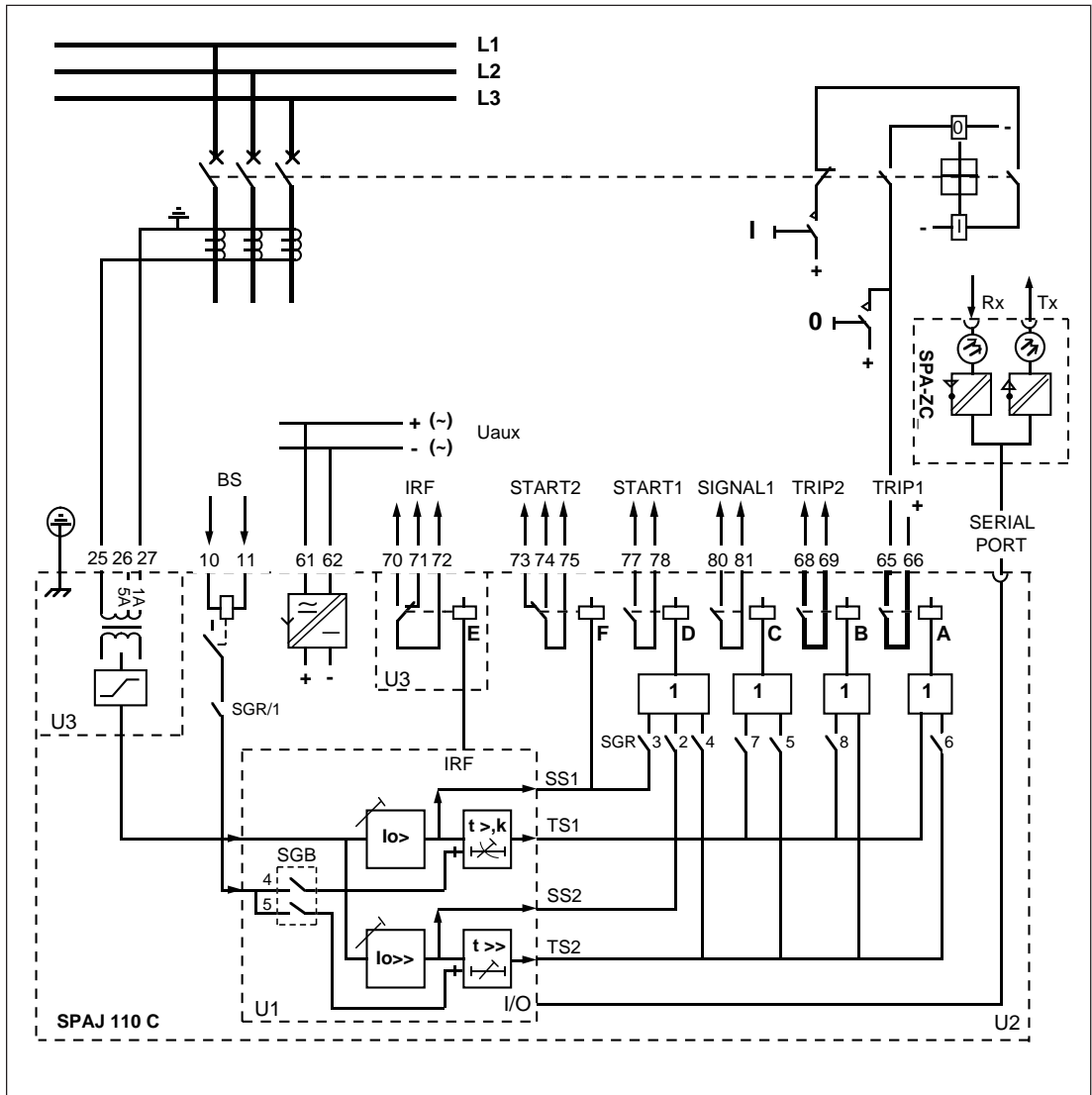

Fig. 2. Connection diagram for the earth-fault relay SPAJ 110 C.

U_{aux}	Auxiliary voltage
A, B, C, D, E, F	Output relays
IRF	Self-supervision function
BS	Blocking signal
SS	Start signal
TS	Trip signal
SGR	Switchgroup for configuring trip and alarm signals
SGB	Switchgroup for configuring blocking signals
TRIP_	Trip output
SIGNAL1	Signal on relay operation
START_	Start signal or signal on relay operation
U1	Non-directional earth-fault relay module SPCJ 1C8
U2	Power supply and I/O module SPTU 240S1 or SPTU 48S1
U3	I/O module SPTE 1E12
SERIAL PORT	Serial communication port
SPA-ZC_	Bus connection module
Rx/Tx	Optical-fibre receiver (Rx) and transmitter (Tx) of the bus connection module

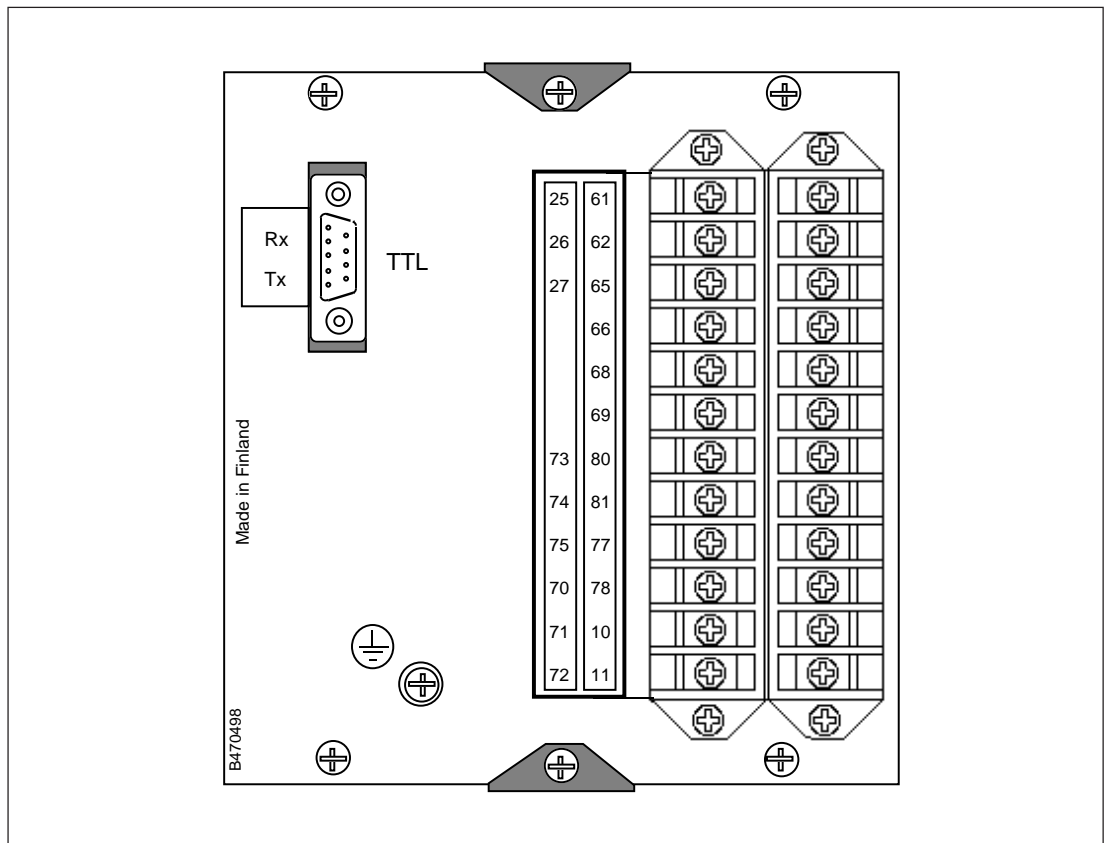



Fig.3. Rear view of earth-fault relay SPAJ 110 C.

Specification of input and output terminals

Contacts	Function
25-26	Neutral current I_0 ($I_n = 5$ A)
25-27	Neutral current I_0 ($I_n = 1$ A)
10-11	External blocking signal (BS)
61-62	Auxiliary power supply. When DC voltage is used the positive pole is connected to terminal 61.
65-66	Trip output 1 for stages $I_{0>}$ and $I_{0>>}$ (TRIP 1)
68-69	Trip output 2 for stages $I_{0>}$ and $I_{0>>}$ (TRIP 2)
80-81	Signal on tripping of stages $I_{0>}$ and $I_{0>>}$ (SIGNAL 1)
77-78	Signal on tripping of stage $I_{0>>}$, start of stages $I_{0>}$ and $I_{0>>}$ (START 1)
73-74-75	Start of stage $I_{0>}$ (START 2). Under normal conditions the contact interval 73-75 is closed. When stage $I_{0>}$ starts, the contact interval 74-75 closes.
70-71-72	Self-supervision (IRF) alarm output. Under normal conditions the contact interval 70-72 is closed. When the auxiliary voltage disappears or an internal fault is detected, the contact interval 71-72 closes.
	Protective earth terminal

The earth-fault relay SPAJ 110 C is connected to the fibre optic data communication bus by means of the bus connection module SPA-ZC 17 or SPA-ZC 21.

The bus connection module is fitted to the D-type connector (SERIAL PORT) on the rear panel of the relay. The opto-connectors of the optical fibres are plugged into the counter connectors Rx and Tx on the bus connection module.

Configuration of output relays

The start signal of the $I_{0>}$ stage is firmly/solidly wired to output relay F and the trip signal to output relay A. The trip signal of the $I_{0>>}$ stage is wired to output relay A. In addition, the

following functions can be selected with the switches of the SGR switchgroup on the front panel:

Switch	Function	Factory setting
SGR/1	Routes the external blocking signal to the neutral current module	1
SGR/2	Routes the start signal of stage $I_{0>>}$ to output relay D	1
SGR/3	Routes the start signal of stage $I_{0>}$ to output relay D	1
SGR/4	Routes the trip signal of stage $I_{0>>}$ to output relay D	1
SGR/5	Routes the trip signal of stage $I_{0>>}$ to output relay C	1
SGR/6	Routes the trip signal of stage $I_{0>>}$ to output relay A	1
SGR/7	Routes the trip signal of stage $I_{0>}$ to output relay C	1
SGR/8	Routes the trip signal of stage $I_{0>}$ to output relay B	1

The circuit breakers can be operated directly both with output relay A or output relay B. Thus either operation stage may have its own output

relay or two separate circuit breakers can be operated with the same protection relay.

Start and operation indicators

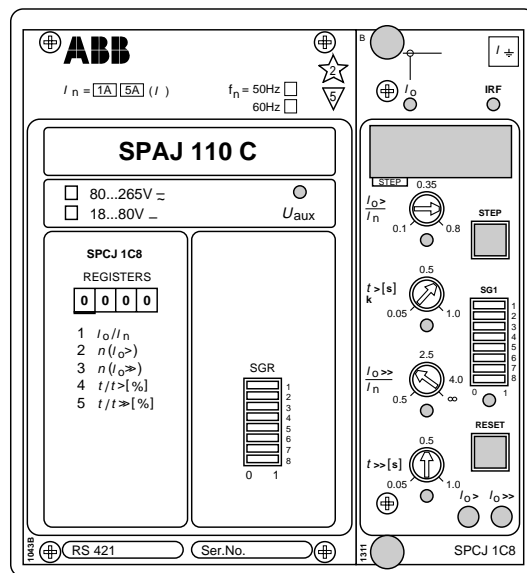

1. Either current stage has its own operation indicator ($I_{0>}$ and $I_{0>>}$), located in the right bottom corner of the front plate of the relay module. Yellow light indicates that the concerned stage has started and red light that the stage has operated (tripped).

With the SG2 software switchgroup the start and trip indicators can be given a latching function, which means that the LEDs remain lit, although the signal that caused operation returns to normal. The indicators are reset with the RESET push-button. An unreset indicator does not affect the operation of the relay.

2. The yellow LED (I_0) on the upper black part of the front plate indicates, when lit, that the value of the neutral current I_0 is currently being displayed.
3. The red IRF indicator of the self-supervision system indicates, when lit, that a permanent internal relay fault has been detected. The fault code appearing on the display once a fault has been detected should be recorded and notified when service is ordered.
4. The green U_{aux} LED on the front panel is lit when the power supply module operates properly.
5. The LED indicator below a setting knob indicates, when lit, that the setting value is being displayed.
6. The LED of the SG1 switchgroup indicates, when lit, that the checksum of the switchgroup is being displayed.

The start and operation indicators, the function of the SG2 software switchgroup and the functions of the LED indicators during setting are described more detailed in manual for the non-directional earth-fault relay module SPCJ 1C8.

Combined power supply and I/O module

The combined power supply and I/O module (U2) is located behind the system front panel of the protection relay and can be withdrawn after removal of the system front panel. The power supply and I/O module incorporates a power unit, five output relays, the control circuits of the output relays and the electronic circuitry of the external control input.

The power unit is transformer connected, that is, the primary side and the secondary circuits are galvanically isolated. The primary side is protected by a slow 1 A fuse F1, placed on the PC board of the module. When the power source operates properly, the green U_{aux} LED on the front panel is lit.

The power supply and I/O module is available in two versions which have different input voltage ranges:

- type SPTU 240 S1 $U_{aux} = 80...265$ V ac/dc
- type SPTU 48 S1 $U_{aux} = 18...80$ V dc

The voltage range of the power supply and I/O module inserted in the relay is marked on the system front panel of the relay.

Technical data
(modified 2002-04)

Energizing inputs

	1 A	5 A
Terminals	25-27	25-26
Rated current I_n	1 A	5 A
Thermal withstand capability		
Carry continuously	4 A	20 A
Make and carry for 10 s	25 A	100 A
Make and carry for 1 s	100 A	500 A
Dynamic current withstand capability, half-wave value	250 A	1250 A
Input impedance	<100 m Ω	<20m Ω
Rated frequency f_n acc. to order	50 Hz or 60 Hz	

Output contact ratings

Terminals	65-66, 68-69
Rated voltage	250 V ac/dc
Carry continuously	5 A
Make and carry for 0.5 s	30 A
Make and carry for 3 s	15 A
Breaking capacity for dc, when the manoeuvre circuit time constant $L/R \leq 40$ ms, at the control voltages	
- 220 V dc	1 A
- 110 V dc	3 A
- 48 V dc	5 A
Signalling contacts	
Terminals	70-71-72, 73-74-75, 77-78, 80-81
Rated voltage	250 V ac/dc
Carry continuously	5 A
Make and carry for 0.5 s	10 A
Make and carry for 3 s	8 A
Breaking capacity for dc, when the signalling circuit time constant $L/R \leq 40$ ms, at the control voltages	
- 220 V dc	0.15 A
- 110 V dc	0.25 A
- 48 V dc	1 A

External control input

Terminals	10-11
Control voltage level	18...265 V dc or 80...265 V ac
Current consumption when input activated	2...20 mA

Auxiliary supply voltage

Power supply and I/O modules and voltage ranges:	
- type SPTU 240 S1	80...265 V ac/dc
- type SPTU 48 S1	18...80 V dc
Power consumption under quiescent/operating conditions	-4 W/-6 W

Non-directional earth-fault relay module SPCJ 1C8

Low-set stage $I_{0>}$	
Start current $I_{0>}$, setting range	0.1...0.8 x I_n
Selectable modes of operation	
- definite time characteristic	
- operate time $t_{>}$	0.05...100 s
- inverse definite minimum time (IDMT) characteristic	
- curve sets acc. to IEC 60255-3 and BS 142	Normal inverse Very inverse Extremely inverse Long-time inverse
- time multiplier k	0.05...1.00
High-set stage $I_{0>>}$	
Start current $I_{0>>}$, setting range	0.1...4.0 x I_n and ∞ , infinite
Operate time $t_{>>}$	0.05...100 s
Data communication	
Transmission mode	Fibre optic serial bus
Data code	ASCII
Selectable data transfer rates	300, 1200, 2400, 4800 or 9600 Bd
Fibre optic bus connection module, powered from the host relay	
- for plastic fibre cables	SPA-ZC 21 BB
- for glass fibre cables	SPA-ZC 21 MM
Fibre optic bus connection module with a built-in power supply unit	
- for plastic fibre cables	SPA-ZC 17 BB
- for glass fibre cables	SPA-ZC 17 MM
Insulation Tests *)	
Dielectric test IEC 60255-5	2 kV, 50 Hz, 1 min
Impulse voltage test IEC 60255-5	5 kV, 1.2/50 μ s, 0.5 J
Insulation resistance measurement IEC 60255-5	>100 M Ω , 500 Vdc
Electromagnetic Compatibility Tests *)	
High-frequency (1 MHz) burst disturbance test IEC 60255-22-1	
- common mode	2.5 kV
- differential mode	1.0 kV
Electrostatic discharge test IEC 60255-22-2 and IEC 61000-4-2	
- contact discharge	6 kV
- air discharge	8 kV
Fast transient disturbance test IEC 60255-22-4 and IEC 61000-4-4	
- power supply	4 kV
- I/O ports	2 kV
Environmental conditions	
Specified ambient service temperature range	-10...+55°C
Long term damp heat withstand acc. to IEC 60068-2-3	<95%, +40°C, 56 d/a
Relative humidity acc. to IEC 60068-2-30	93...95%, +55°C, 6 cycles
Transport and storage temperature range	-40...+70°C
Degree of protection by enclosure for panel mounted relay	IP 54
Weight of relay including flush mounting case	3.0 kg

*) The tests do not apply to the serial port, which is used exclusively for the bus connection module.