

# Installation Instructions

Original Instructions



**Allen-Bradley**

by ROCKWELL AUTOMATION

## FLEX I/O Terminal Base Units

Catalog Numbers 1794-TB2, 1794-TB2K, 1794-TB3, 1794-TB3K, 1794-TB3S, 1794-TB32, 1794-TB32S, 1794-TB32SK, 1794-TB32K, 1794-TB3G, 1794-TB3GK, 1794-TB3GS, 1794-TB3T, 1794-TB3TS, 1794-TBN, 1794-TBNK, 1794-TBNF, 1794-TB3SK, 1794-TB3GSK, 1794-TB3TK, 1794-TB3TSK

Catalog numbers with the suffix 'K' are conformally coated to meet noxious gas requirements of ISA/ANSI-71.040 1985 Class G3 Environment.

Topic	Page
Summary of Changes	1
Terminal Base Overview	5
Mount the Terminal Base Unit on a DIN Rail	6
Wire Connections	8
Install or Change a Fuse in the 1794-TBNF Terminal Base Unit	10
Use the Knife Switch Terminal Base	10
Specifications	11
Mounting Dimension	14
Additional Resources	14

### Summary of Changes

This publication contains the following new or updated information. This list includes substantive updates only and is not intended to reflect all changes.

Topic	Page
Updated Certifications	13
Added Additional Resources	14



**ATTENTION:** Read this document and the documents listed in the Additional Resources section about installation, configuration and operation of this equipment before you install, configure, operate or maintain this product. Users are required to familiarize themselves with installation and wiring instructions in addition to requirements of all applicable codes, laws, and standards.

Activities including installation, adjustments, putting into service, use, assembly, disassembly, and maintenance are required to be carried out by suitably trained personnel in accordance with applicable code of practice. If this equipment is used in a manner not specified by the manufacturer, the protection provided by the equipment may be impaired.

注意：在安装、配置、操作和维护本产品前，请阅读本文档以及“其他资源”部分列出的有关设备安装、配置和操作的相应文档。除了所有适用规范、法律和标准的相关要求之外，用户还必须熟悉安装和接线说明。

安装、调整、投运、使用、组装、拆卸和维护等各项操作必须由经过适当训练的专业人员按照适用的操作规范实施。

如果未按照制造商指定的方式使用该设备，则可能会损害设备提供的保护。

**ATENCIÓN:** Antes de instalar, configurar, poner en funcionamiento o realizar el mantenimiento de este producto, lea este documento y los documentos listados en la sección Recursos adicionales acerca de la instalación, configuración y operación de este equipo. Los usuarios deben familiarizarse con las instrucciones de instalación y cableado y con los requisitos de todos los códigos, leyes y estándares vigentes.

El personal debidamente capacitado debe realizar las actividades relacionadas a la instalación, ajustes, puesta en servicio, uso, ensamblaje, desensamblaje y mantenimiento de conformidad con el código de práctica aplicable. Si este equipo se usa de una manera no especificada por el fabricante, la protección provista por el equipo puede resultar afectada.

**ATENÇÃO:** Leia este e os demais documentos sobre instalação, configuração e operação do equipamento que estão na seção Recursos adicionais antes de instalar, configurar, operar ou manter este produto. Os usuários devem se familiarizar com as instruções de instalação e fiação além das especificações para todos os códigos, leis e normas aplicáveis.

É necessário que as atividades, incluindo instalação, ajustes, colocação em serviço, utilização, montagem, desmontagem e manutenção sejam realizadas por pessoal qualificado e especializado, de acordo com o código de prática aplicável.

Caso este equipamento seja utilizado de maneira não estabelecida pelo fabricante, a proteção fornecida pelo equipamento pode ficar prejudicada.

**ВНИМАНИЕ:** Перед тем как устанавливать, настраивать, эксплуатировать или обслуживать данное оборудование, прочитайте этот документ и документы, перечисленные в разделе «Дополнительные ресурсы». В этих документах изложены сведения об установке, настройке и эксплуатации данного оборудования. Пользователи обязаны ознакомиться с инструкциями по установке и прокладке соединений, а также с требованиями всех применимых норм, законов и стандартов.

Все действия, включая установку, наладку, ввод в эксплуатацию, использование, сборку, разборку и техническое обслуживание, должны выполняться обученным персоналом в соответствии с применимыми нормами и правилами.

Если оборудование используется не предусмотренным производителем образом, защита оборудования может быть нарушена.

注意：本製品を設置、構成、稼働または保守する前に、本書および本機器の設置、設定、操作についての参考資料の該当箇所に記載されている文書に目を通してください。ユーザは、すべての該当する条例、法律、規格の要件に加えて、設置および配線の手順に習熟している必要があります。

設置調整、運転の開始、使用、組立て、解体、保守を含む諸作業は、該当する実施規則に従って訓練を受けた適切な作業員が実行する必要があります。

本機器が製造メーカーにより指定されていない方法で使用されている場合、機器により提供されている保護が損なわれる恐れがあります。

**ACHTUNG:** Lesen Sie dieses Dokument und die im Abschnitt „Weitere Informationen“ aufgeführten Dokumente, die Informationen zu Installation, Konfiguration und Bedienung dieses Produkts enthalten, bevor Sie dieses Produkt installieren, konfigurieren, bedienen oder warten. Anwender müssen sich neben den Bestimmungen aller anwendbaren Vorschriften, Gesetze und Normen zusätzlich mit den Installations- und Verdrahtungsanweisungen vertraut machen.

Arbeiten im Rahmen der Installation, Anpassung, Inbetriebnahme, Verwendung, Montage, Demontage oder Instandhaltung dürfen nur durch ausreichend geschulte Mitarbeiter und in Übereinstimmung mit den anwendbaren Ausführungsvorschriften vorgenommen werden.

Wenn das Gerät in einer Weise verwendet wird, die vom Hersteller nicht vorgesehen ist, kann die Schutzfunktion beeinträchtigt sein.

**ATTENTION :** Lisez ce document et les documents listés dans la section Ressources complémentaires relatifs à l'installation, la configuration et le fonctionnement de cet équipement avant d'installer, configurer, utiliser ou entretenir ce produit. Les utilisateurs doivent se familiariser avec les instructions d'installation et de câblage en plus des exigences relatives aux codes, lois et normes en vigueur. Les activités relatives à l'installation, le réglage, la mise en service, l'utilisation, l'assemblage, le démontage et l'entretien doivent être réalisées par des personnes formées selon le code de pratique en vigueur.

Si cet équipement est utilisé d'une façon qui n'a pas été définie par le fabricant, la protection fournie par l'équipement peut être compromise.

주의：본 제품 설치, 설정, 작동 또는 유지보수하기 전에 본 문서를 포함하여 설치, 설정 및 작동에 관한 참고 자료 섹션의 문서들을 반드시 읽고 숙지하십시오. 사용자는 모든 관련 규정, 법규 및 표준에서 요구하는 사항에 대해 반드시 설치 및 배선 지침을 숙지해야 합니다.

설치, 조정, 가동, 사용, 조립, 분해, 유지보수 등 모든 작업은 관련 규정에 따라 적절한 교육을 받은 사용자를 통해서만 수행해야 합니다.

본 장비를 제조사가 명시하지 않은 방법으로 사용하면 장비의 보호 기능이 손상될 수 있습니다.

**ATTENZIONE** Prima di installare, configurare ed utilizzare il prodotto, o effettuare interventi di manutenzione su di esso, leggere il presente documento ed i documenti elencati nella sezione "Altre risorse", riguardanti l'installazione, la configurazione ed il funzionamento dell'apparecchiatura. Gli utenti devono leggere e comprendere le istruzioni di installazione e cablaggio, oltre ai requisiti previsti dalle leggi, codici e standard applicabili.

Le attività come installazione, regolazioni, utilizzo, assemblaggio, disassemblaggio e manutenzione devono essere svolte da personale adeguatamente addestrato, nel rispetto delle procedure previste. Qualora l'apparecchio venga utilizzato con modalità diverse da quanto previsto dal produttore, la sua funzione di protezione potrebbe venire compromessa.

**DIKKAT:** Bu ürünün kurulumu, yapilandirilmasi, isletilmesi veya bakimi öncesinde bu dokümanı ve bu ekipmanın kurulumu, yapilandirilmasi ve isletimi ile ilgili ilave Kaynaklar bölümünde yer listelenmiş dokümanları okuyun. Kullanıcılar yürürlükteki tüm yönetmelikler, yasalar ve standartların gereksinimlerine ek olarak kurulum ve kablolama talimatlarını da öğrenmek zorundadır.

Kurulum, ayarlama, hizmete alma, kullanma, parçaları birleştirme, parçaları sökme ve bakım gibi aktiviteler sadece uygun eğitimleri almış kişiler tarafından yürürlükteki uygulama yönetmeliklerine uygun şekilde yapılabilir.

Bu ekipman üretici tarafından belirlenmiş amacın dışında kullanılırsa, ekipman tarafından sağlanan koruma bozulabilir.

注意事項：在安装、設定、操作或維護本產品前，請先閱讀此文件以及列於「其他資源」章節中有關安裝、設定與操作此設備的文件。使用者必須熟悉安裝和配線指示，並符合所有法規、法律和標準要求。

包括安裝、調整、交付使用、使用、組裝、拆卸和維護等動作都必須交由已經過適當訓練的人員進行，以符合適用的實作法規。

如果將設備用於非製造商指定的用途時，可能會造成設備所提供的保護功能受損。

**POZOR:** Než začnete instalovat, konfigurovat či provozovat tento výrobek nebo provádět jeho údržbu, přečtěte si tento dokument a dokumenty uvedené v části Dodatečné zdroje ohledně instalace, konfigurace a provozu tohoto zařízení. Uživatelé se musejí vedle požadavků všech relevantních vyhlásek, zákonů a norem nutně seznámit také s pokyny pro instalaci a elektrické zapojení.

Činnosti zahrnující instalaci, nastavení, uvedení do provozu, užívání, montáž, demontáž a údržbu musí vykonávat vhodné proškolený personál v souladu s příslušnými prováděcími předpisy.

Pokud se toto zařízení používá způsobem neodpovídajícím specifikaci výrobce, může být narušena ochrana, kterou toto zařízení poskytuje.

**UWAGA:** Przed instalacją, konfiguracją, użytkowaniem lub konserwacją tego produktu należy przeczytać niniejszy dokument oraz wszystkie dokumenty wymienione w sekcji Dodatkowe źródła omawiające instalację, konfigurację i procedury użytkowania tego urządzenia. Użytkownicy mają obowiązek zapoznać się z instrukcjami dotyczącymi instalacji oraz przewożenia, jak również z obowiązującymi kodeksami, prawem i normami.

Działania obejmujące instalację, regulację, przekazanie do użytkowania, użytkowanie, montaż, demontaż oraz konserwację muszą być wykonywane przez odpowiednio przeszkolony personel zgodnie z obowiązującym kodeksem postępowania.

Jeśli urządzenie jest użytkowane w sposób inny niż określony przez producenta, zabezpieczenie zapewniane przez urządzenie może zostać ograniczone.

**OBST!** Läs detta dokument samt dokumentet, som står listat i avsnittet Övriga resurser, om installation, konfiguration och drift av denna utrustning innan du installerar, konfigurerar eller börjar använda eller utföra underhållsarbete på produkten. Användare måste bekanta sig med instruktioner för installation och kabeldragning, förutom krav enligt gällande koder, lagar och standarder.

Åtgärder som installation, justering, service, användning, montering, demontering och underhållsarbete måste utföras av personal med lämplig utbildning enligt lämpligt bruk.

Om denna utrustning används på ett sätt som inte anges av tillverkaren kan det hända att utrustningens skyddsanordningar försätts ur funktion.

**LET OP:** Lees dit document en de documenten die genoemd worden in de paragraaf Aanvullende informatie over de installatie, configuratie en bediening van deze apparatuur voordat u dit product installeert, configureert, bedient of onderhoudt. Gebruikers moeten zich vertrouwd maken met de installatie en de bedradingsinstructies, naast de vereisten van alle toepasselijke regels, wetten en normen.

Activiteiten zoals het installeren, afstellen, in gebruik stellen, gebruiken, monteren, demonteren en het uitvoeren van onderhoud mogen uitsluitend worden uitgevoerd door hiervoor opgeleid personeel en in overeenstemming met de geldende praktijkregels.

Indien de apparatuur wordt gebruikt op een wijze die niet is gespecificeerd door de fabrikant, dan bestaat het gevaar dat de beveiliging van de apparatuur niet goed werkt.

## Environment and Enclosure



**ATTENTION:** This equipment is intended for use in a Pollution Degree 2 industrial environment, in overvoltage Category II applications (as defined in EN/IEC 60664-1), at altitudes up to 2000 m (6562 ft) without derating. This equipment is not intended for use in residential environments and may not provide adequate protection to radio communication services in such environments.

This equipment is supplied as open-type equipment for indoor use. It must be mounted within an enclosure that is suitably designed for those specific environmental conditions that will be present and appropriately designed to prevent personal injury resulting from accessibility to live parts. The enclosure must have suitable flame-retardant properties to prevent or minimize the spread of flame, complying with a flame spread rating of 5VA or be approved for the application if nonmetallic. The interior of the enclosure must be accessible only by the use of a tool. Subsequent sections of this publication may contain more information regarding specific enclosure type ratings that are required to comply with certain product safety certifications.

In addition to this publication, see the following:

- Industrial Automation Wiring and Grounding Guidelines, Rockwell Automation® publication [1770-4.1](#), for more installation requirements.
- NEMA Standards 250 and IEC 60529, as applicable, for explanations of the degrees of protection provided by different types of enclosure.



**WARNING:** When you insert or remove the module while backplane power is on, an electric arc can occur. This could cause an explosion in hazardous location installations. Be sure that power is removed or the area is nonhazardous before proceeding.



**WARNING:** If you connect or disconnect wiring while the field-side power is on, an electric arc can occur. This could cause an explosion in hazardous location installations. Be sure that power is removed or the area is nonhazardous before proceeding.



**ATTENTION:** This product is grounded through the DIN rail to chassis ground. Use zinc-plated chromate-passivated steel DIN rail to assure proper grounding. The use of other DIN rail materials (for example, aluminum or plastic) that can corrode, oxidize, or are poor conductors, can result in improper or intermittent grounding. Secure DIN rail to mounting surface approximately every 200 mm (7.8 in.) and use end-anchors appropriately. Be sure to ground the DIN rail properly. See the Industrial Automation Wiring and Grounding Guidelines, Rockwell Automation publication [1770-4.1](#), for more information.

## Prevent Electrostatic Discharge



**ATTENTION:** This equipment is sensitive to electrostatic discharge, which can cause internal damage and affect normal operation. Follow these guidelines when you handle this equipment:

- Touch a grounded object to discharge potential static.
- Wear an approved grounding wriststrap.
- Do not touch connectors or pins on component boards.
- Do not touch circuit components inside the equipment.
- Use a static-safe workstation, if available.
- Store the equipment in appropriate static-safe packaging when not in use.



**ATTENTION:** Do not remove or replace a Terminal Base unit while power is applied. Interruption of the backplane can result in unintentional operation or machine motion.



**ATTENTION:** Do not wire more than 1 conductor on any single terminal.





**ATTENTION:** Personnel responsible for the application of safety-related Programmable Electronic Systems (PES) shall be aware of the safety requirements in the application of the system and shall be trained in using the system.



**WARNING:** Terminal bases 1794-TB2, 1794-TB2K, 1794-TBN, 1794-TBNK, 1794-TB3, 1794-TB3K, 1794-TB3S, 1794-TB3SK, 1794-TB3T, 1794-TB3TK, 1794-TB3TS, and 1794-TB3TSK are not approved for use above 60V AC or 75V DC in ATEX/IECEx/UKEX applications.

## North American Hazardous Location Approval

The following terminal bases are Hazardous Location approved: 1794-TB2, 1794-TB2K, 1794-TB3, 1794-TB3K, 1794-TB3S, 1794-TB32, 1794-TB32S, 1794-TB3G, 1794-TB3GK, 1794-TB3GS, 1794-TB3T, 1794-TB3TS, 1794-TBN, 1794-TBNK, 1794-TBNF, 1794-TB3SK, 1794-TB3GSK, 1794-TB3TK, and 1794-TB3TSK

The Following Information Applies When Operating This Equipment In Hazardous Locations.		Informations sur l'utilisation de cet équipement en environnements dangereux.	
<p>Products marked "CL I, DIV 2, GP A, B, C, D" are suitable for use in Class I Division 2 Groups A, B, C, D, Hazardous Locations and nonhazardous locations only. Each product is supplied with markings on the rating nameplate indicating the hazardous location temperature code. When combining products within a system, the most adverse temperature code (lowest "T" number) may be used to help determine the overall temperature code of the system. Combinations of equipment in your system are subject to investigation by the local Authority Having Jurisdiction at the time of installation.</p>		<p>Les produits marqués "CL I, DIV 2, GP A, B, C, D" ne conviennent qu'à une utilisation en environnements de Classe I Division 2 Groupes A, B, C, D dangereux et non dangereux. Chaque produit est livré avec des marquages sur sa plaque d'identification qui indiquent le code de température pour les environnements dangereux. Lorsque plusieurs produits sont combinés dans un système, le code de température le plus défavorable (code de température le plus faible) peut être utilisé pour déterminer le code de température global du système. Les combinaisons d'équipements dans le système sont sujettes à inspection par les autorités locales qualifiées au moment de l'installation.</p>	
	<p><b>WARNING:</b> <b>Explosion Hazard -</b></p> <ul style="list-style-type: none"> <li>Do not disconnect equipment unless power has been removed or the area is known to be nonhazardous.</li> <li>Do not disconnect connections to this equipment unless power has been removed or the area is known to be nonhazardous. Secure any external connections that mate to this equipment by using screws, sliding latches, threaded connectors, or other means provided with this product.</li> <li>Substitution of components may impair suitability for Class I Division 2.</li> </ul>		<p><b>AVERTISSEMENT:</b> <b>Risque d'Explosion -</b></p> <ul style="list-style-type: none"> <li>Couper le courant ou s'assurer que l'environnement est classé non dangereux avant de débrancher l'équipement.</li> <li>Couper le courant ou s'assurer que l'environnement est classé non dangereux avant de débrancher les connecteurs. Fixer tous les connecteurs externes reliés à cet équipement à l'aide de vis, loquets coulissants, connecteurs filetés ou autres moyens fournis avec ce produit.</li> <li>La substitution de composants peut rendre cet équipement inadapté à une utilisation en environnement de Classe I Division 2.</li> </ul>

## UK and European Hazardous Location Approval

The following adapters are European Zone 2 approved: 1794-TB2, 1794-TB2K, 1794-TB3, 1794-TB3K, 1794-TB3S, 1794-TB3G, 1794-TB3GK, 1794-TB3GS, 1794-TB3T, 1794-TB3TS, 1794-TBN, 1794-TBNK, 1794-TB3SK, 1794-TB3GSK, 1794-TB3TK, and 1794-TB3TSK

### The following applies to products marked :

- Are Equipment Group II, Equipment Category 3, and comply with the Essential Health and Safety Requirements relating to the design and construction of such equipment given in Schedule 1 of UKEX and Annex II of EU Directive 2014/34/EU. See the UKEX and EU Declaration of Conformity at [rok.auto/certifications](http://rok.auto/certifications) for details.
- The type of protection is Ex ec IIC T4 Gc or Ex ec IIC T6 Gc according to EN IEC 60079-0:2018, EXPLOSIVE ATMOSPHERES - PART 0: EQUIPMENT - GENERAL REQUIREMENTS, Issue Date 07/2018 and EN IEC 60079-7:2015+A1:2018, Explosive atmospheres. Equipment protection by increased safety "e".
- Comply with Standard EN IEC 60079-0:2018, EXPLOSIVE ATMOSPHERES - PART 0: EQUIPMENT - GENERAL REQUIREMENTS, Issue Date 07/2018, EN IEC 60079-7:2015+A1:2018 Explosive atmospheres. Equipment protection by increased safety "e", reference certificate number DEMKO 14 ATEX 1342501X and UL22UKEX2378X.
- Are intended for use in areas in which explosive atmospheres caused by gases, vapors, mists, or air are unlikely to occur, or are likely to occur only infrequently and for short periods. Such locations correspond to Zone 2 classification according to UKEX regulation 2016 No. 1107 and ATEX directive 2014/34/EU.
- May have catalog numbers followed by a "K" to indicate a conformal coating option.

## IEC Hazardous Location Approval

### The following applies to products with IECEx certification:

- Are intended for use in areas in which explosive atmospheres caused by gases, vapors, mists, or air are unlikely to occur, or are likely to occur only infrequently and for short periods. Such locations correspond to Zone 2 classification to IEC 60079-0.
- The type of protection is Ex ec IIC T4 Gc or Ex ec IIC T6 Gc according to IEC 60079-0 and IEC 60079-7.
- Comply with Standards IEC 60079-0, Explosive atmospheres Part 0: Equipment - General requirements, Edition 7, Revision Date 2017, IEC 60079-7, 5.1 Edition revision date 2017, Explosive atmospheres - Part 7: Equipment protection by increased safety "e", reference IECEx certificate number IECEx UL 14.0066X.
- May have catalog numbers followed by a "K" to indicate a conformal coating option.



**WARNING: Special Conditions for Safe Use**

- This equipment shall be mounted in an UKEX/ATEX/IECEx Zone 2 certified enclosure with a minimum ingress protection rating of at least IP54 (in accordance with EN/IEC 60079-0) and used in an environment of not more than Pollution Degree 2 (as defined in EN/IEC 60664-1) when applied in Zone 2 environments. The enclosure must be accessible only by the use of a tool.
- This equipment shall be used within its specified ratings defined by Rockwell Automation.
- Transient protection shall be provided that is set at a level not exceeding 140% of the peak rated voltage value at the supply terminals to the equipment.
- This equipment must be used only with UKEX/ATEX/IECEx certified Rockwell Automation backplanes.
- Secure any external connections that mate to this equipment by using screws, sliding latches, threaded connectors, or other means provided with this product.
- Do not disconnect equipment unless power has been removed or the area is known to be nonhazardous.
- Earthing is accomplished through mounting of modules on rail.
- Modules 1794-TB2, 1794-TB2K, 1794-TBN, 1794-TBNK, 1794-TB3, 1794-TB3K, 1794-TB3S, 1794-TB3SK, 1794-TB3T, 1794-TB3TK, 1794-TB3TS, and 1794-TB3TSK must be used at or below 60V AC or 75V DC.

**Terminal Base Overview**

FLEX™ I/O terminal bases are a required part of the FLEX I/O family. Which terminal base you need depends on the specific FLEX I/O module requirements. See [Table 1](#) for terminal base unit descriptions.

**FLEX I/O Cage-clamp Terminal Base Units - 1794-TB2, 1794-TB3, 1794-TB3K, 1794-TB32, 1794-TB3G, 1794-TB3GK, 1794-TB3T, 1794-TB3TK**

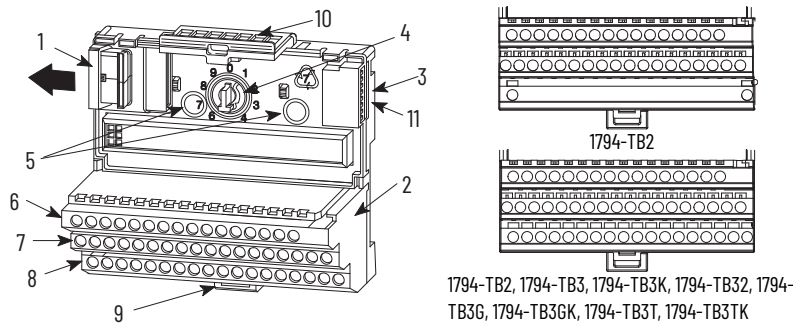

**FLEX I/O Spring-clamp Terminal Base Units - 1794-TB3S, 1794-TB3SK, 1794-TB32S, 1794-TB3GS, 1794-TB3GSK, 1794-TB3TS, 1794-TB3TSK**

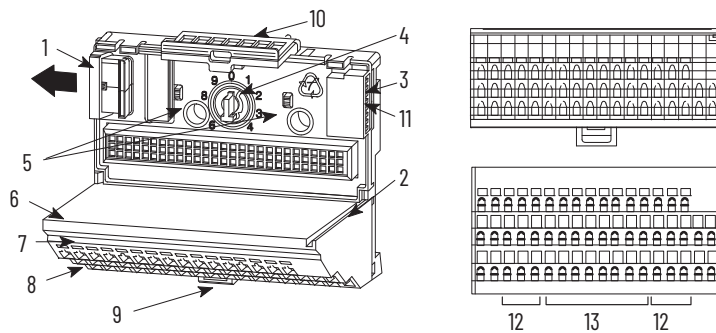

**FLEX I/O Terminal Base Units - 1794-TBN, 1794-TBNK**

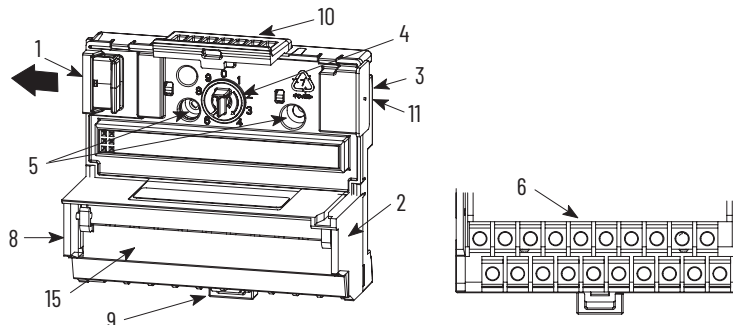

FLEX I/O Fused Terminal Base Units - 1794-TBNF, 1794-TBNFK

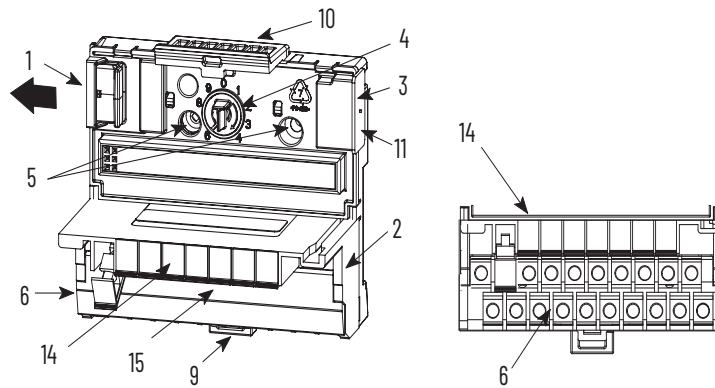

Table 1 - Terminal Base Unit Description

	Description
1	Female Flexbus connector
2	Terminal base unit
3	Male Flexbus connector
4	Keyswitch - Set to the position required for the installed module
5	Mounting holes for panel mounting
6, 7, & 8	Input/output terminal strips for connecting inputs/output wiring, commons, power connections, customer power supplies, and chassis grounds
9	Locking tab
10	Module locking latch
11	Cover plug for male Flexbus connector
12	Cold junction compensation terminals - 1794-TB3T, 1794-TB3TS, 1794-TB3TK, 1794-TB3TSK only
13	Chassis ground terminations - 1794-TB3T, 1794-TB3TS, 1794-TB3TK, 1794-TB3TSK, 1794-TB3G, 1794-TB3GS, 1794-TB3GSK only
14	Fuses - Eight 5 x 20 mm - 1794-TBNF only
15	Terminal strip cover - 1794-TBN, 1794-TBNK, 1794-TBNF only

### Mount the Terminal Base Unit on a DIN Rail



**ATTENTION:** During mounting of all devices, be sure that all debris (such as metal chips or wire strands) are kept from falling into the module. Debris that falls into the module could cause damage upon application of power.

1. Remove the cover plug (if used) in the male connector of the unit to which you are connecting this terminal base unit.
2. Check to make sure that the 16 pins in the male connector on the adjacent device are straight and in line so that the mating female connector on this terminal base unit will mate correctly.
3. Make sure that the female connector **(B)** is fully retracted.
4. Position the terminal base unit on the 35 x 7.5 mm DIN rail (A) (Allen-Bradley® catalog number 199-DR1) at a slight angle and hook it over the top of the DIN rail.



**ATTENTION:** Do not force the terminal base into the adjacent base/adaptor. Forcing the units together can bend or break the hook and allow the units to separate and break communication over the backplane.

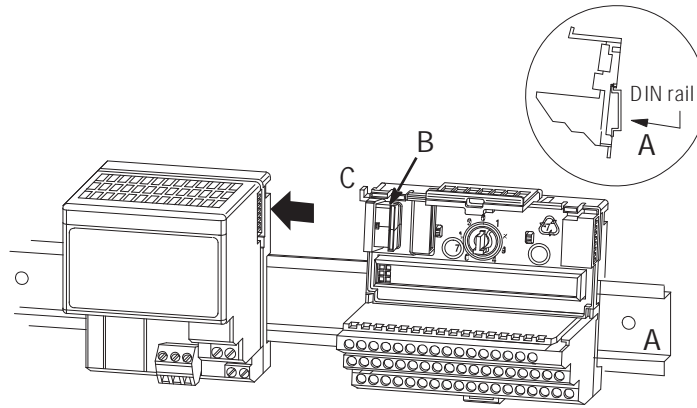

5. Make sure the hook (C) on the terminal base slides under the edge of the adapter and the Flexbus connector is fully retracted. Slide the terminal base over, tight against the adapter.
6. Rotate the terminal base onto the DIN rail with the top of the rail hooked under the lip on the rear of the terminal base. **Make sure that the female Flexbus connector does not strike any of the pins in the mating connector.**
7. Press down on the terminal base to lock it on the DIN rail. If the terminal base does not lock into place, use a screwdriver or similar device to open the locking tab, press down on the base, and release the locking lever to lock the base in place.

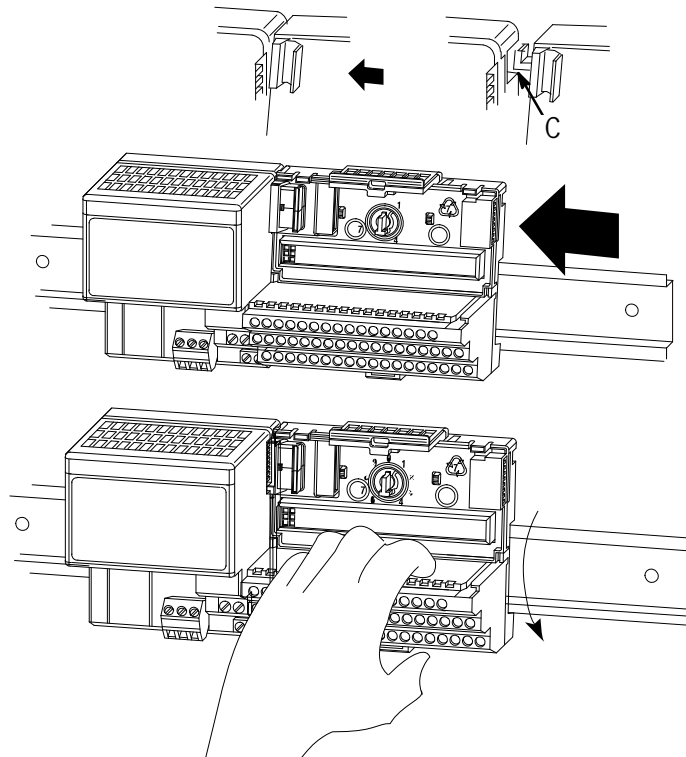

8. Gently push the Flexbus connector into the side of the adapter to complete the backplane connection.

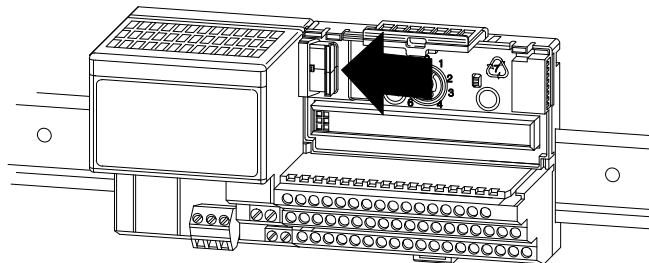

9. See the installation instructions for specific wiring information for the module you are installing in this terminal base. To install the next terminal base, repeat the preceding steps.



**ATTENTION:** When using FLEX I/O modules in a high-vibration installation, especially when mounting the DIN rail vertically, use DIN rail locks (Allen-Bradley catalog number 1492-EA35) to prevent accidental separation of the terminal block units.

## Wire Connections

### Wire Connections for 1794-TB32, 1794-TB32K, 1794-TB32S, 1794-TB32SK Terminal Bases

1794-TB32 shown

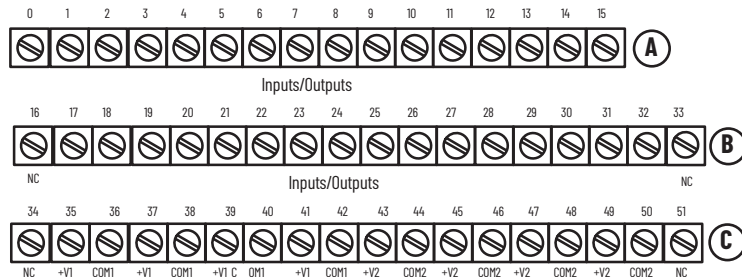

+V1 = Terminals 35, 37, 39, 41  
 +V2 = Terminals 43, 45, 47, 49  
 COM1 = Terminals 36, 38, 40, 42  
 COM2 = Terminals 44, 46, 48, 50  
 NC = No connections (Terminals 16, 33, 34, 51)

### Wire Connections for 1794-TB2, 1794-TB2K, 1794-TB3, 1794-TB3K, 1794-TB3S, 1794-TB3S Terminal Bases

1794-TB3 shown

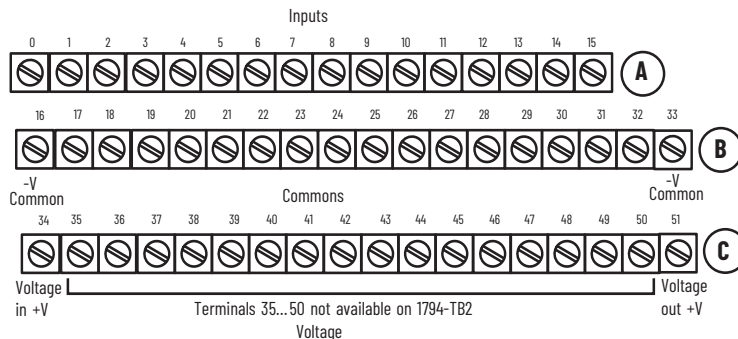

-V (Common) = Terminals B-16 and B-33  
 +V (Voltage in) = Terminals C-34 and C-51  
 For daisy chaining: Supply in - C-34 (+) and B-16 (-)  
 Supply out - C-51 (+) and B-33 (-)

### Wire Connections for 1794-TB3G, 1794-TB3GK, 1794-TB3GS, 1794-TB3GSK Terminal Bases

1794-TB3G shown

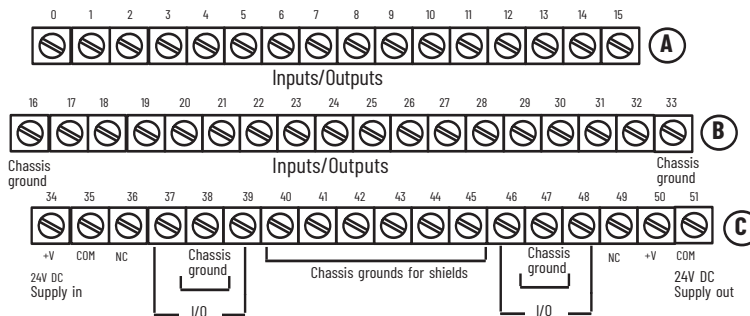

+24V DC = Terminals C-34, C-50  
 COM = C-35, C-51  
 Chassis ground = Terminals B-16, B-33, C-38, C-40...45, C-  
 NC = No connection  
 For daisy chaining: Supply in - C-34 (+), C-35 (-)  
 Supply out - C-50 (+) and C-51 (-)

### Wire Connections for 1794-TB3G, 1794-TB3GK, 1794-TB3GS, 1794-TB3GSK Terminal Bases

1794-TBN shown

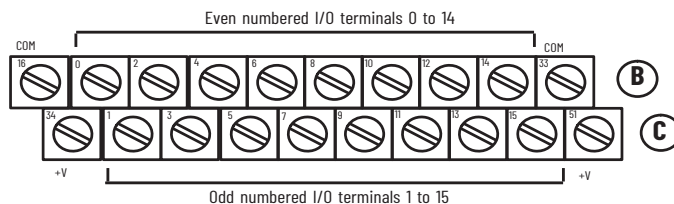

+V = Terminals C-34, C-51  
 COM (-V) = Terminals B-16, B-33

Wire Connections for 1794-TB3T, 1794-TB3TK, 1794-TB3TS, 1794-TB3TSK Terminal Bases

1794-TB3T shown

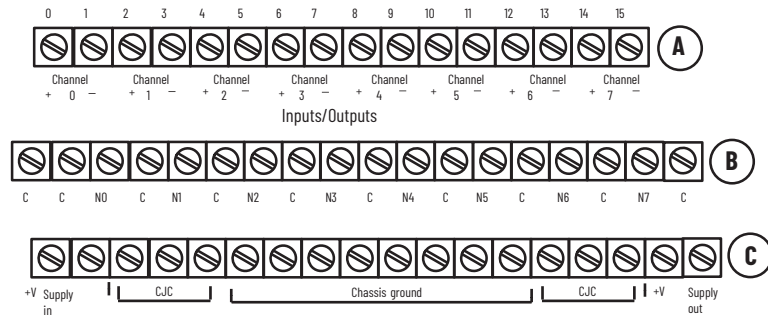

+V = 24V DC Supply in - Terminals C-34, C-35  
 -V = 24V DC Common - Terminal B-16  
 +V = Supply out - Terminals C-50, C-51  
 -V = Terminal B-33  
 C = -V DC common

Typical Wiring Guidelines

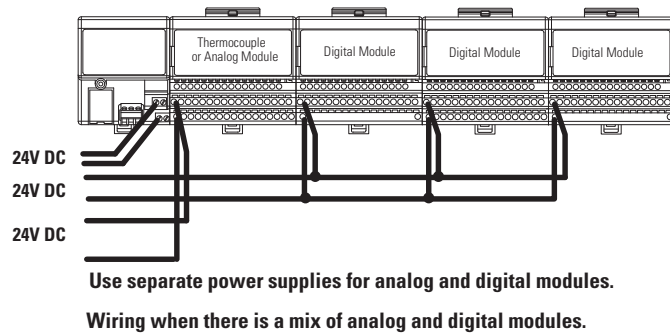
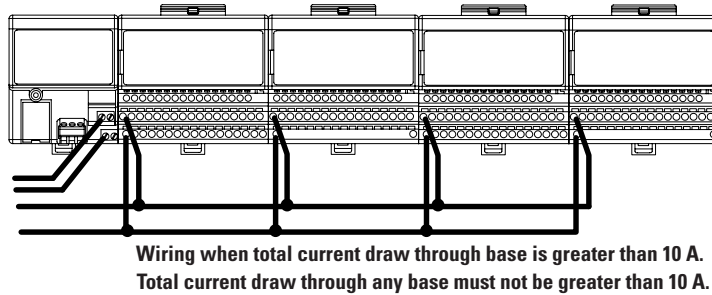
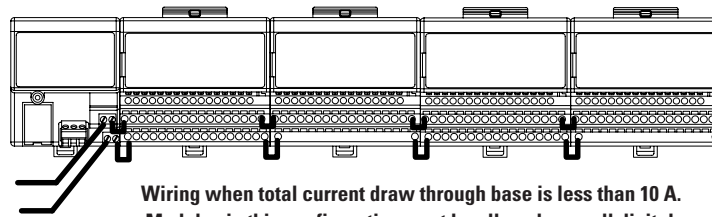

Terminal base units are rated at 10 A.

For Spring-clamp Terminal Base Units: 1794-TB3S, 1794-TB3TS, 1794-TB3GS, 1794-TB32S, 1794-TB32SK, 1794-TB3SK, 1794-TB3TSK, and 1794-TB3GSK

- Insert a 2.54...3.05 mm (0.10...0.12 in.) wide-bladed screwdriver into the slot and lift.
- Insert wire and remove screwdriver.

## Install or Change a Fuse in the 1794-TBNF Terminal Base Unit

This terminal base unit has fuse holders for 5x20 mm fuses on each of the eight even-numbered I/O terminals (0...14 - row B). To install or change a fuse, proceed as follows:

1. Press the fuse holder down toward the terminal strip.

Press down to open.

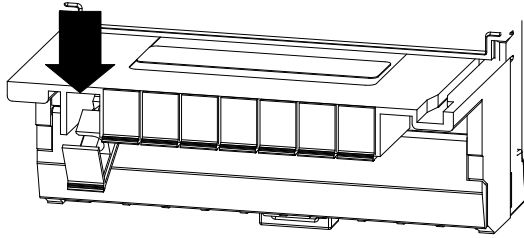

2. Remove the fuse from the fuse holder.
3. Insert a 5x20 mm fuse into the fuse holder.
4. Rotate the fuse holder back to vertical until it snaps into the locked position.

The 1794-TBNF terminal base units are shipped with eight 5x20 mm, 1.6 A, 250V AC slow-blow fuses, one for each even-numbered terminal (0...14 on row B). These fuses are suitable for use with the 1794-OA8 AC output module. See the specific installation instructions for fusing recommendations for your particular module.

## Use the Knife Switch Terminal Base

The knife switch terminal base has 16 individual mechanical-knifed-switch circuit breakers (two for each channel). Each switch opens or closes one side (input/output and return) for a channel.

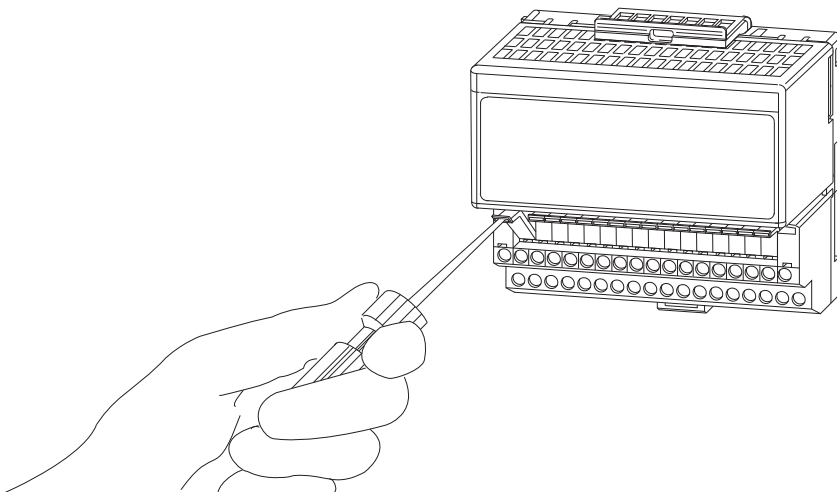

1. Place a small-bladed screwdriver into the slot of the knife switch of the I/O point circuit that you wish to break.
2. Rotate downward to open the circuit. This opens the path of an individual circuit.
3. To re-establish the circuit, rotate the knife switch back into the terminal base unit until it snaps into place.

## Specifications

### General Specifications

Attribute	Value
Terminal screw torque	<p><b>For 1794-TB3TK, 1794-TB3G, 1794-TB3GK, 1794-TB2, 1794-TB2K, 1794-TB32, 1794-TB32K, 1794-TB3, 1794-TB3K, 1794-TB3T:</b> 0.56...0.79 N•m (5...7 lb•in)</p> <p><b>For 1794-TBN, 1794-TBNF, 1794-TBNK:</b> 1.4 N•m (12 lb•in)</p>
Supply voltage range, max	<p><b>For 1794-TB3SK, 1794-TB3TK, 1794-TB2, 1794-TB2K, 1794-TB3, 1794-TB3K, 1794-TB3S, 1794-TB3TK, 1794-TB3TS:</b> Flexbus: 5V DC, 640 mA I/O Terminals: 2 A max V/COM Terminals: 125V DC/AC, 50/60 Hz, 10 A</p> <p><b>For 1794-TB3GSK, 1794-TB3G, 1794-TB3GS, 1794-TB3GK, 1794-TB32, 1794-TB32K, 1794-TB32S, 1794-TB32SK:</b> V/COM Terminals: 31.2V DC/AC, 50/60 Hz, 10 A</p> <p><b>For 1794-TBN, 1794-TBNF, 1794-TBNK:</b> V/COM Terminals: 250V DC/AC, 50/60 Hz, 10 A</p> <p><b>For 1794-TB2, 1794-TB2K, 1794-TBN, 1794-TBNK, 1794-TB3, 1794-TB3K, 1794-TB3S, 1794-TB3SK, 1794-TB3T, 1794-TB3TK, 1794-TB3TS, 1794-TB3TSK:</b> (UKEX/ATEX/IECEX) V/COM Terminals: 60V AC, 50/60 Hz</p> <p><b>For 1794-TB2, 1794-TB2K, 1794-TBN, 1794-TBNK, 1794-TB3, 1794-TB3K, 1794-TB3S, 1794-TB3SK, 1794-TB3T, 1794-TB3TK, 1794-TB3TS, 1794-TB3TSK:</b> (UKEX/ATEX/IECEX) V/COM Terminals: 75V DC</p> <hr/> <p> <b>ATTENTION:</b> A disconnecting switch does not shut off the current. Make or break a circuit only under no-load conditions.</p>
Isolation voltage	<p><b>For 1794-TBN, 1794-TBNF, 1794-TBNK:</b> Capable of 250V (continuous) max, Basic Insulation Type, Field Wiring Terminals to Flexbus, or the lesser of the installed module.</p> <p><b>For 1794-TB3SK, 1794-TB3TK, 1794-TB3TK, 1794-TB3TSK, 1794-TB2, 1794-TB2K, 1794-TB3, 1794-TB3K, 1794-TB3S, 1794-TB3TS:</b> Capable of 125V (continuous) max, Basic Insulation Type, Field Wiring Terminals to Flexbus, or the lesser of the installed module.</p> <p><b>For 1794-TB3G, 1794-TB3GS, 1794-TB3GK, 1794-TB3GSK, 1794-TB32, 1794-TB32K, 1794-TB32S, 1794-TB32SK:</b> Capable of 50V (continuous) max, Basic Insulation Type, Field Wiring Terminals to Flexbus, or the lesser of the installed module. 2500V DC/s, Field Wiring Terminals to Flexbus.</p>
Voltage rating	See <a href="#">Working Voltage and Isolation Voltage Ratings on page 12</a> for nominal values.
Enclosure type rating	None (open-style)
Wire size	<p><b>For 1794-TB3SK, 1794-TB3GSK, 1794-TB3TSK, 1794-TB3GK, 1794-TB3GS, 1794-TB32S, 1794-TB32SK, 1794-TB3, 1794-TB3K, 1794-TB3S, 1794-TB3TS, 1794-TBN, 1794-TBNF, 1794-TBNK:</b> 0.34...3.3 mm<sup>2</sup> (22...12 AWG) solid or stranded copper wire rated at 105 °C (221 °F) or greater, 1.2 mm (3/64 in.) insulation max Strip Length: 5...6 mm (0.20...0.24 in.)</p> <p><b>For 1794-TB3TK, 1794-TB3G, 1794-TB2, 1794-TB2K, 1794-TB32, 1794-TB32K:</b> 0.21...1.3 mm<sup>2</sup> (24...16 AWG) stranded copper wire rated at 105 °C (221 °F) or greater, 1.2 mm (3/64 in.) insulation max</p>
Wiring category <sup>(1)</sup>	Established by the installed module
North American temp code	<p><b>For 1794-TB3G, 1794-TB3GS, 1794-TB3GSK, 1794-TB3GK, 1794-TB3, 1794-TB3K, 1794-TB3T, 1794-TB3TK, 1794-TB3S, 1794-TB3SK, 1794-TB3TS, 1794-TB3TSK, 1794-TBN, 1794-TBNK, 1794-TB32, 1794-TB32S:</b> T4A</p> <p><b>For 1794-TB2, 1794-TB2K:</b> T6</p>

**General Specifications (Continued)**

Attribute	Value
UKEX/ATEX temp code	<p><b>For 1794-TB3G, 1794-TB3GS, 1794-TB3GSK, 1794-TB3GK, 1794-TB3, 1794-TB3K, 1794-TB3T, 1794-TB3TK, 1794-TB3S, 1794-TB3SK, 1794-TB3TS, 1794-TB3TSK, 1794-TBN, 1794-TBNK:</b> T4</p> <p><b>For 1794-TB2, 1794-TB2K:</b> T6</p>
IECEx temp code	<p><b>For 1794-TB3G, 1794-TB3GS, 1794-TB3GSK, 1794-TB3GK, 1794-TB3, 1794-TB3K, 1794-TB3T, 1794-TB3TK, 1794-TB3S, 1794-TB3SK, 1794-TB3TS, 1794-TB3TSK, 1794-TBN, 1794-TBNK:</b> T4</p> <p><b>For 1794-TB2, 1794-TB2K:</b> T6</p>
Dimensions, approx (H x W x D)	94 x 94 x 69 mm (3.7 x 3.7 x 2.7 in.) (with module installed in terminal base)

(1) Use this Conductor Category information for planning conductor routing. See Industrial Automation Wiring and Grounding Guidelines, publication [1770-4.1](#).

**Environmental Specifications**

Attribute	Value
Operating temperature	<p>IEC 60068-2-1 (Test Ad, Operating Cold), IEC 60068-2-2 (Test Bd, Operating Dry Heat), IEC 60068-2-14 (Test Nb, Operating Thermal Shock):</p> <p><b>For 1794-TB3G, 1794-TB3GS, 1794-TB3GSK, 1794-TB3GK, 1794-TB3, 1794-TB3K, 1794-TB3T, 1794-TB3TK, 1794-TB3S, 1794-TB3SK, 1794-TB3TS, 1794-TB3TSK, 1794-TB32, 1794-TB32K, 1794-TB32S, 1794-TB32SK, 1794-TBN, 1794-TBNK:</b> -20...+70 °C (-4...+158 °F)</p> <p><b>For 1794-TBNF, 1794-TBNFK, 1794-TB2, 1794-TB2K:</b> -20...+55 °C (-4...+131 °F)</p>
Nonoperating temperature	<p>IEC 60068-2-1 (Test Ab, Unpackaged nonoperating Cold), IEC 60068-2-2 (Test Bb, Unpackaged nonoperating Dry Heat), IEC 60068-2-14 (Test Na, Unpackaged nonoperating Thermal Shock): -40...+85 °C (-40...+185 °F)</p>
Relative humidity	IEC 60068-2-30 (Test Db, Unpackaged Damp Heat): 5...95% noncondensing
Vibration	IEC 60068-2-6 (Test Fc, Operating): 5 g @ 10...500 Hz
Operating shock	IEC 60068-2-27 (Test Ea, Unpackaged Shock): 30 g
Nonoperating shock	IEC 60068-2-27 (Test Ea, Unpackaged Shock): 50 g

**Working Voltage and Isolation Voltage Ratings**

Terminal Base	24V	120V	230V	Isolation Voltage
1794-TBN, 1794-TBNK, 1794-TBNF	AC/DC	AC/DC	AC/DC	Dependent upon installed module - See the individual installation instructions for your specific module.
1794-TB2, 1794-TB2K, 1794-TB3, 1794-TB3K, 1794-TB3S, 1794-TB3SK	AC/DC	AC/DC		
1794-TB3T, 1794-TB3TS, 1794-TB3TK, 1794-TB3TSK	AC/DC	AC/DC		
1794-TB3G, 1794-TB3GK, 1794-TB3GS, 1794-TB3GSK	AC/DC			
1794-TB32, 1794-TB32K, 1794-TB32S, 1794-TB32SK	AC/DC			

## Certifications

Certifications (when product is marked) <sup>(1)</sup>	Value
c-UL-us	UL Listed Industrial Control Equipment, certified for US and Canada. See UL File E65584. UL Listed for Class I Division 2 Group A,B,C,D Hazardous Locations, certified for U.S. and Canada. See UL File E194810.
UK and CE	UK Statutory Instrument 2016 No. 1091 and European Union 2014/30/EU EMC Directive, compliant with: EN 61326-1; Meas./Control/Lab., Industrial Requirements EN 61000-6-2; Industrial Immunity EN 61131-2; Programmable Controllers EN 61000-6-4; Industrial Emissions  UK Statutory Instrument 2016 No. 1101 and European Union 2014/35/EU LVD, compliant with: EN 61131-2; Programmable Controllers (Clause 11)  UK Statutory Instrument 2012 No. 3032 and European Union 2011/65/EU RoHS, compliant with: EN 63000; Technical documentation
RCM	Australian Radiocommunications Act, compliant with: EN 61000-6-4; Industrial Emissions
Ex	UK Statutory Instrument 2016 No. 1107 and European Union 2014/34/EU ATEX Directive, compliant with: EN 60079-0; General Requirements EN 60079-7; Explosive Atmospheres, Protection "e"  <b>For 1794-TB3, 1794-TB3K, 1794-TB3S, 1794-TB3SK, 1794-TB3G, 1794-TB3GK, 1794-TB3GS, 1794-TB3T, 1794-TB3TS, 1794-TB3GSK, 1794-TB3TK, 1794-TB3TSK, 1794-TBN, 1794-TBNK:</b> II 3 G Ex ec IIC T4 Gc  <b>For 1794-TB2, 1794-TB2K:</b> II 3 G Ex ec IIC T6 Gc DEMKO 14 ATEX 1342501X UL22UKEX2378X  <b>Note:</b> 1794-TB2, 1794-TB2K, 1794-TBN, 1794-TBNK, 1794-TB3, 1794-TB3K, 1794-TB3S, 1794-TB3SK, 1794-TB3T, 1794-TB3TK, 1794-TB3TS, and 1794-TB3TSK must be used at or below 60V or 75V DC
IECEX	IECEX System, compliant with: IEC 60079-0; General Requirements IEC 60079-7; Explosive Atmospheres, Protection "e"  <b>For 1794-TB3G, 1794-TB3GK, 1794-TB3GS, 1794-TB3T, 1794-TB3TS, 1794-TB3GSK, 1794-TB3TK, 1794-TB3TSK, 1794-TB3, 1794-TB3K, 1794-TB3S, 1794-TB3SK, 1794-TBN, 1794-TBNK:</b> Ex ec IIC T4 Gc  <b>For 1794-TB2, 1794-TB2K:</b> Ex ec IIC T6 Gc IECEX UL 14.0066X  <b>Note:</b> 1794-TB2, 1794-TB2K, 1794-TBN, 1794-TBNK, 1794-TB3, 1794-TB3K, 1794-TB3S, 1794-TB3SK, 1794-TB3T, 1794-TB3TK, 1794-TB3TS, and 1794-TB3TSK must be used at or below 60V or 75V DC
TÜV	<b>For 1794-TB3G, 1794-TB3GS, 1794-TB3GSK, 1794-TB3GK, 1794-TB3, 1794-TB3K, 1794-TB3T, 1794-TB3S, 1794-TB3TS, 1794-TB3TK, 1794-TB3SK, 1794-TB3TSK, 1794-TBNF, 1794-TBNFK:</b> TÜV Certified for Functional Safety: Capable of SIL 2
KC	Korean Registration of Broadcasting and Communications Equipment, compliant with: Article 58-2 of Radio Waves Act, Clause 3
Morocco	Arrêté ministériel n° 6404-15 du 1 er muharram 1437 Arrêté ministériel n° 6404-15 du 29 ramadan 1436
CCC	<b>For 1794-TB2, 1794-TB2K, 1794-TB3, 1794-TB3K, 1794-TB3S, 1794-TB3G, 1794-TB3GK, 1794-TB3GS, 1794-TB3T, 1794-TB3TS, 1794-TBN, 1794-TBNK, 1794-TB3SK, 1794-TB3GSK, 1794-TB3TK, 1794-TB3TSK:</b> CNCA-C23-01 强制性产品认证实施规则 防爆电气 CNCA-C23-01 CCC Implementation Rule Explosion-Proof Electrical Products

(1) See the Product Certification link at [rok.auto/certifications](http://rok.auto/certifications) for Declaration of Conformity, Certificates, and other certification details.

## Mounting Dimension

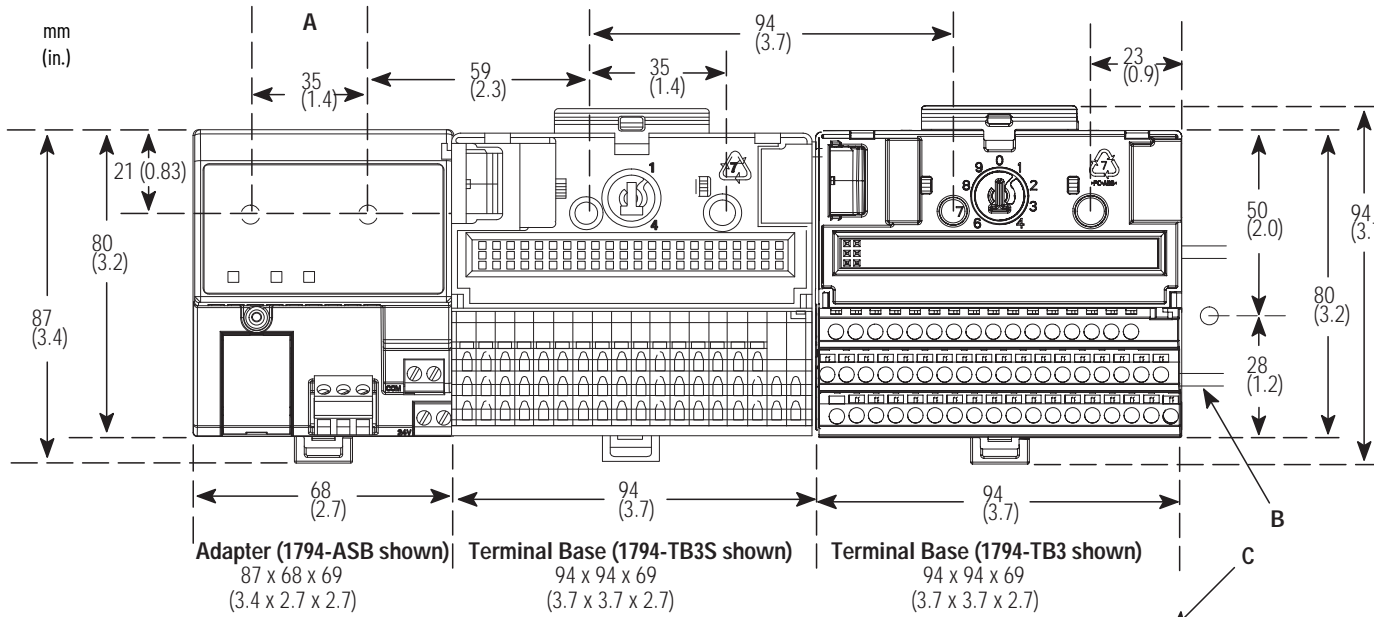

Secure DIN rail approximately every 200 mm (7.87 in.).

Maintain at least 25.4 (1.0) air space around your FLEX I/O system installation.

A = Mounting hole dimensions for optional mounting kit

B = DIN rail

C = Operating temperature 25.4 (1.0) below each module when mounted in any position must not exceed 55 °C (131 °F)

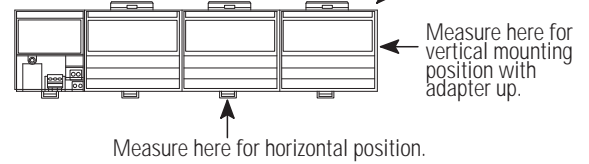

## Additional Resources

For more information on the products that are described in this publication, use these resources. You can view or download publications at [rok.auto/literature](http://rok.auto/literature).

Resource	Description
FLEX I/O and FLEX I/O-XT Selection Guide, publication <a href="#">1794-SG002</a>	Provides specifications for selecting FLEX I/O and FLEX I/O-XT™ products.
Industrial Automation Wiring and Grounding Guidelines, publication <a href="#">1770-4.1</a>	Provides general guidelines for installing a Rockwell Automation industrial system.
Product Certifications website, <a href="http://rok.auto/certifications">rok.auto/certifications</a>	Provides declarations of conformity, certificates, and other certification details.

**Notes:**

## Rockwell Automation Support

Use these resources to access support information.

<b>Technical Support Center</b>	Find help with how-to videos, FAQs, chat, user forums, Knowledgebase, and product notification updates.	<a href="http://rok.auto/support">rok.auto/support</a>
<b>Local Technical Support Phone Numbers</b>	Locate the telephone number for your country.	<a href="http://rok.auto/phonesupport">rok.auto/phonesupport</a>
<b>Technical Documentation Center</b>	Quickly access and download technical specifications, installation instructions, and user manuals.	<a href="http://rok.auto/techdocs">rok.auto/techdocs</a>
<b>Literature Library</b>	Find installation instructions, manuals, brochures, and technical data publications.	<a href="http://rok.auto/literature">rok.auto/literature</a>
<b>Product Compatibility and Download Center (PCDC)</b>	Download firmware, associated files (such as AOP, EDS, and DTM), and access product release notes.	<a href="http://rok.auto/pcdc">rok.auto/pcdc</a>

## Documentation Feedback

Your comments help us serve your documentation needs better. If you have any suggestions on how to improve our content, complete the form at [rok.auto/docfeedback](http://rok.auto/docfeedback).





## Waste Electrical and Electronic Equipment (WEEE)



At the end of life, this equipment should be collected separately from any unsorted municipal waste.

Rockwell Automation maintains current product environmental compliance information on its website at [rok.auto/pec](http://rok.auto/pec).

Rockwell Otomasyon Ticaret A.Ş. Kar Plaza İş Merkezi E Blok Kat:6 34752 İçerenköy, İstanbul, Tel: +90 (216) 5698400 EEE Yönetmeliğine Uygundur

Connect with us.    

**rockwellautomation.com** — expanding **human possibility**<sup>®</sup>

AMERICAS: Rockwell Automation, 1201 South Second Street, Milwaukee, WI 53204-2496 USA, Tel: (1) 414.382.2000

EUROPE/MIDDLE EAST/AFRICA: Rockwell Automation NV, Pegasus Park, De Kleetlaan 12a, 1831 Diegem, Belgium, Tel: (32) 2663 0600

ASIA PACIFIC: Rockwell Automation SEA Pte Ltd, 2 Corporation Road, #04-05, Main Lobby, Corporation Place, Singapore 618494, Tel: (65) 6510 6608

UNITED KINGDOM: Rockwell Automation Ltd., Pitfield, Kiln Farm, Milton Keynes, MK11 3DR, United Kingdom, Tel: (44)(1908) 838-800

Allen-Bradley, expanding human possibility, FactoryTalk, FLEX, FLEX I/O-XT, Rockwell Automation, and TechConnect are trademarks of Rockwell Automation, Inc.

Trademarks not belonging to Rockwell Automation are property of their respective companies.

Publication 1794-IN092H-EN-P - March 2024 | Supersedes Publication 1794-IN092G-EN-P - October 2022

Copyright © 2024 Rockwell Automation, Inc. All rights reserved.